

RXGF Media Air Cleaner

PRODUCT DATA



FEATURES

- **Efficiency and arrestance ratings based on the American Society of Heating, Refrigerating and Air Conditioning- Engineers Standard 52.2-1999.**
 - Applicable to all gas, oil, and electric forced warm air furnaces and to compressor cooling up to 5 tons.
- **Mounts in the return air duct.**
- **Cabinet can support weight of residential furnace and evaporator coil.**
- **Requires no electrical connections.**
- **Mounts in any position.**
- **Requires no maintenance except periodic media filter replacement.**
- **Quick and easy media filter replacement.**

APPLICATION

The RXGF Media Air Cleaner captures a significant amount of the air-borne particles from the air circulated through the unit.

Use with gas, oil, and electric forced warm air furnaces and with compressor cooling. Can be used with heat pumps if filter is changed regularly to prevent excessive pressure drop. Not recommended for applications where pressure drop may be critical.



SPECIFICATIONS

IMPORTANT

The specifications in this publication do not include normal manufacturing tolerances; therefore, an individual unit may not exactly match the listed specifications. This product is tested and calibrated under closely controlled conditions, and some minor differences in performance can be expected if those conditions are changed.

RXGF Media Air Cleaner includes cabinet, access door and pleated media filter.

RXGF Efficiency:

Efficiency Ratings: Based on American Society of Heating, Refrigerating and Air-Conditioning Engineers Standard 52.2-1999. Minimum efficiency reporting value (MERV) at 492 fpm.

RXGF MERV 10

Filter Media:

Pleated for greater media capacity.

Capacity And Pressure Drop:

See Fig. 2.

Initial Pressure Drop: 0.233 in. wc at 492 fpm.

Temperature Rating:

-40° to +140°F (-40° to +60°C).

Dimensions:

See Fig. 1.

Mounting:

Mounts in any position in the return air duct, usually next to the furnace blower compartment. Cabinet is sturdy enough to support weight of a residential furnace and evaporator coil.

Approvals:

Underwriters Laboratories, Inc.: Listed to UL 900, Class 2.

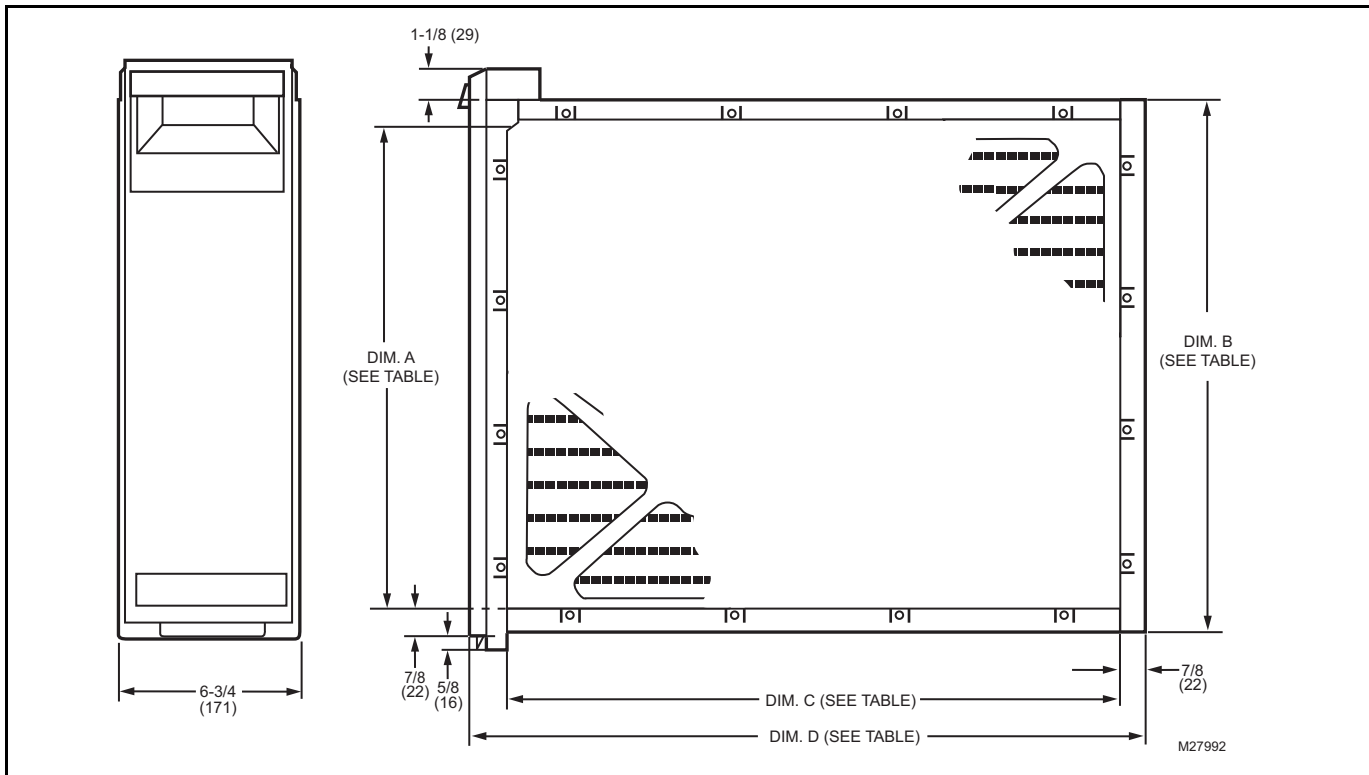

Fig. 1. Installation dimensions in in. (mm) of air cleaner. See table below.

RXGF SIZE		DIM. A		DIM. B.		DIM. C		DIM. D	
IN.	MM	IN.	MM	IN.	MM	IN.	MM	IN.	MM
28 x 17.5	711 X 445	15 3/4	400	17 15/32	444	26 15/64	666	28 1/2	724
28 x 21	711 X 533	19 15/64	489	21	533	26 15/64	666	28 1/2	724
28 x 24.5	711 X 622	22 3/4	578	24 15/32	621	26 15/64	666	28 1/2	724

Replacement Media:

For optimum system performance, replace the filter every six months (before heating season and before cooling sea-

son). Adjust the schedule to your needs, but replace the filter at least annually.

Table 1. Replacement filters.

Filter Size (in.)	MERV 10 Part number
28 x 17.5	540011
28 x 21	540013
28 x 24.5	540015

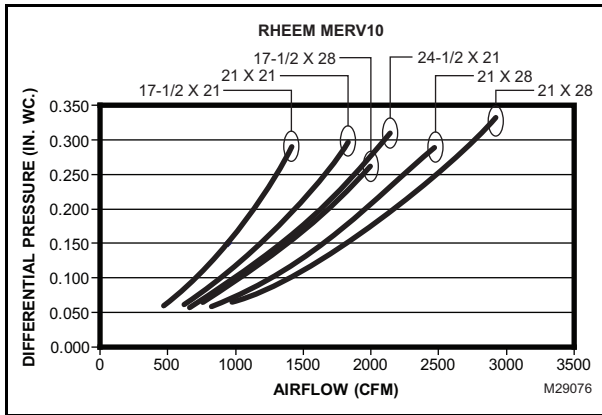

Fig. 2. Capacity, pressure drop and area of RXGF filter media.

PLANNING THE INSTALLATION

Location

The media air cleaner should be installed where all the air passing through the system is circulated through it. The best location is in the return air duct next to the blower compartment so the media air cleaner can help to keep the blower motor and evaporator coils clean. Do not mount in the supply air duct. For most efficient air cleaning, spread airflow evenly across the face of the media. If the duct is a different size than the media air filter cabinet, gradual transitions are required. If the duct turns sharply just before the air filter, turning vanes are required. Choose a location that is readily accessible for checking and replacing the filter. Allow at least 26 in. (660 mm) clearance in front of the unit for removal of the cartridge. Install the media air filter where the temperature will not exceed the ratings in the Specifications.

Applications With Air Conditioning

Mount the media air cleaner upstream of the evaporator coil in a cooling system. The filter will help to keep the coil clean and reduce maintenance.

Applications With A Humidifier

The media air cleaner is compatible with humidifiers. Avoid applications where water mist will reach the media. If atomizing humidifier is used, the filter media will require replacement more often because of minerals in the water.

Choose Mounting Position

The media air cleaner can be mounted in any position, but the arrow on the cartridge must point in the same direction as the airflow. See Figs. 3-10 for proper location of the media air cleaner for a variety of furnace installations. Note that the media air cleaner cabinet is sturdy enough to easily support the weight of the furnace and evaporator coil. See Fig. 4.

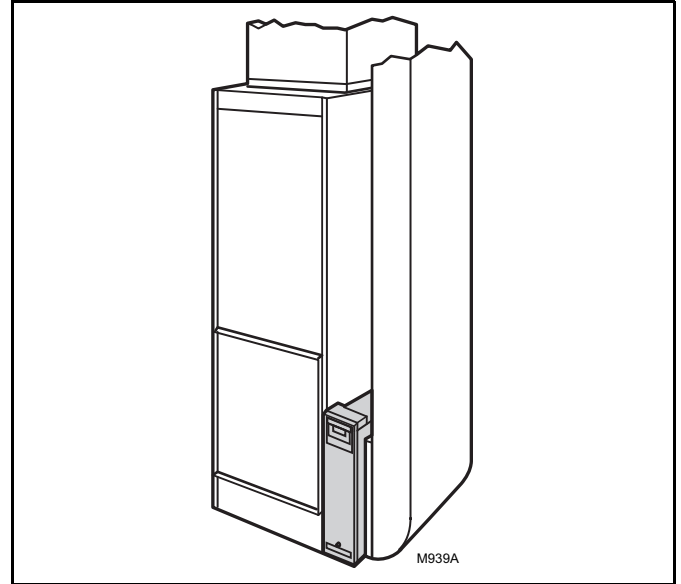

Fig. 3. Highboy furnace, with side installation. Media air filter is mounted vertically where return enters side inlet of furnace.

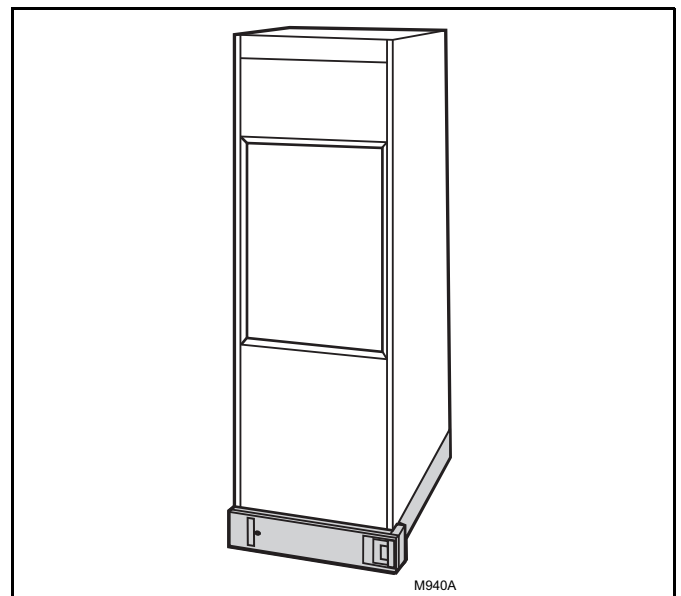

Fig. 4. Highboy furnace, with installation beneath furnace. Media air cleaner is mounted horizontally where return enters from below.

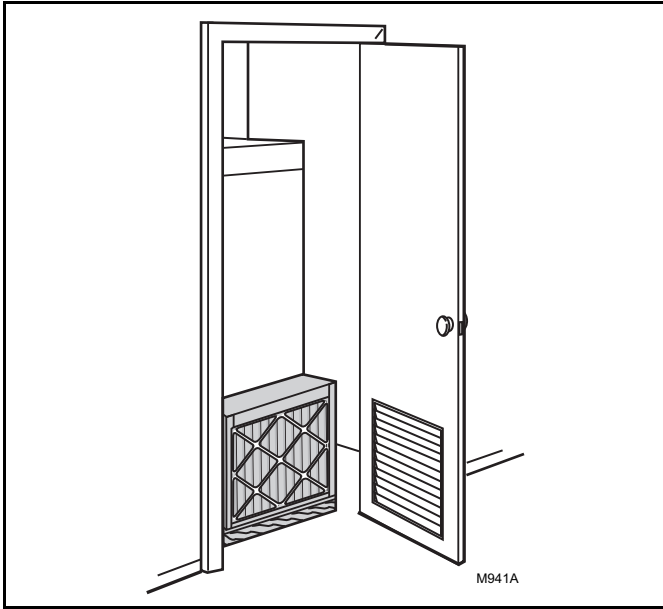

Fig. 5. Highboy furnace, with closet installation. Media air cleaner is mounted vertically on furnace between furnace and louvered return air opening in closet door.

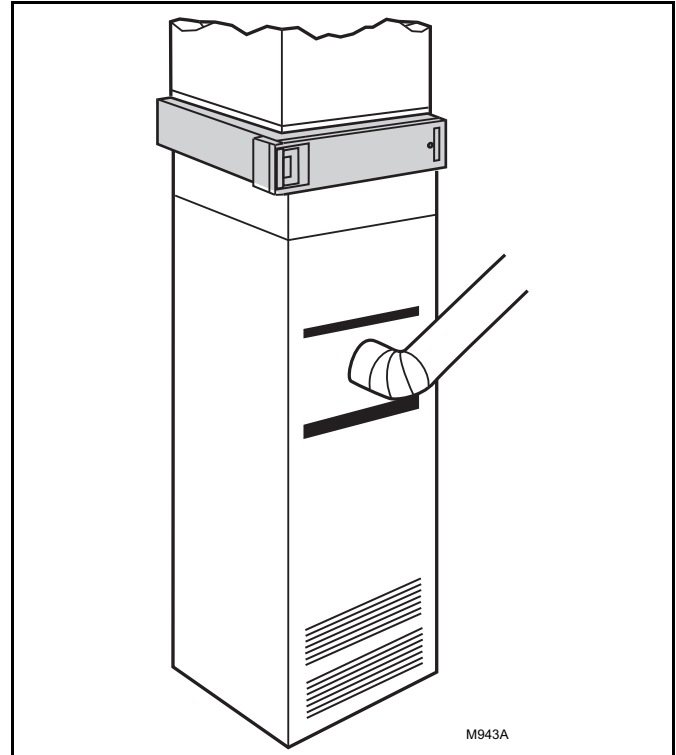

Fig. 7. Counterflow furnace, with media air cleaner mounted horizontally in return duct or plenum just above furnace.

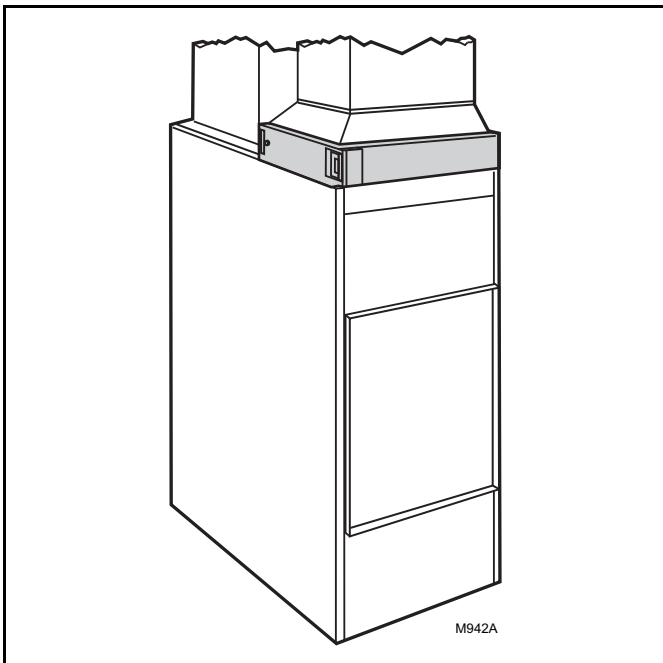

Fig. 6. Lowboy furnace, with media air cleaner mounted horizontally in return plenum just above furnace and opposite heating plenum.

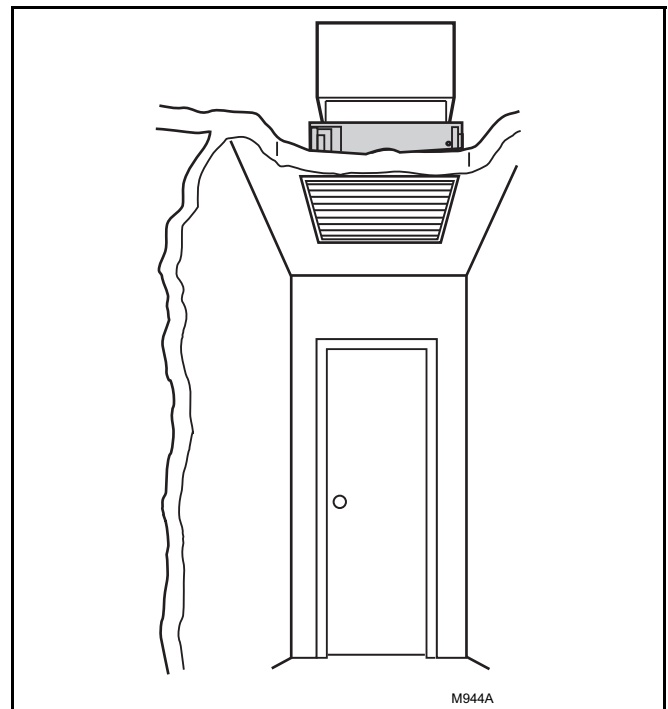

Fig. 8. Central fan installation, with media air cleaner mounted horizontally in central return duct.

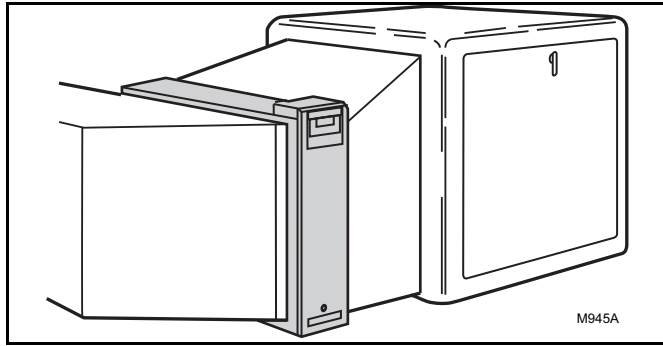

Fig. 9. Horizontal furnace, with media air filter mounted vertically in return duct near furnace.

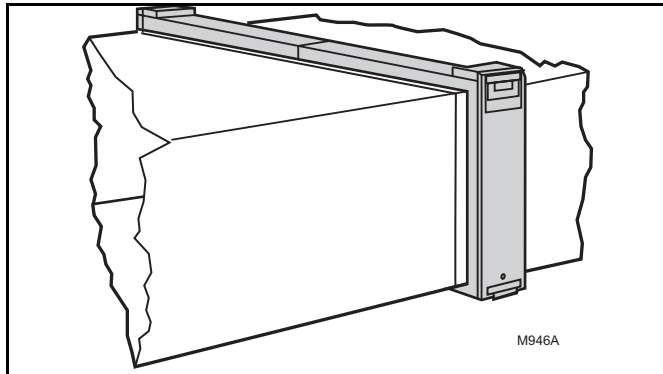

Fig. 10. Two or more media air cleaners used in a high capacity system.

Determining Sheet metal Requirements

The media air cleaner is adaptable to all new or existing forced air heating and cooling systems used in residential applications. Transitions or turning vanes may be required in some applications for effective media air cleaner operation.

Transitions

Transitions are needed when the duct is a different size than the media air cleaner cabinet. Follow these guidelines when fabricating:

1. Use gradual transitions to reduce air turbulence and increase efficiency. See Fig. 11.
2. Use no more than 20 degrees (about 4 in. per running ft. (100 mm per 300 linear mm)) of expansion on each side of a transition fitting.

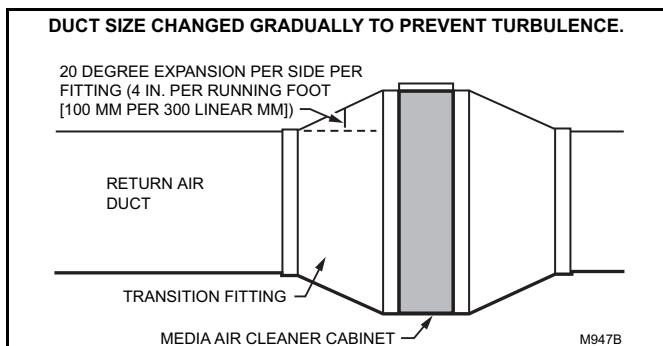

Fig. 11. Duct size changed gradually to prevent turbulence.

Turning Vanes

If the media air cleaner is installed next to an elbow or angle fitting, add turning vanes inside the angle to distribute airflow more evenly across the face of the media. See Fig. 12.

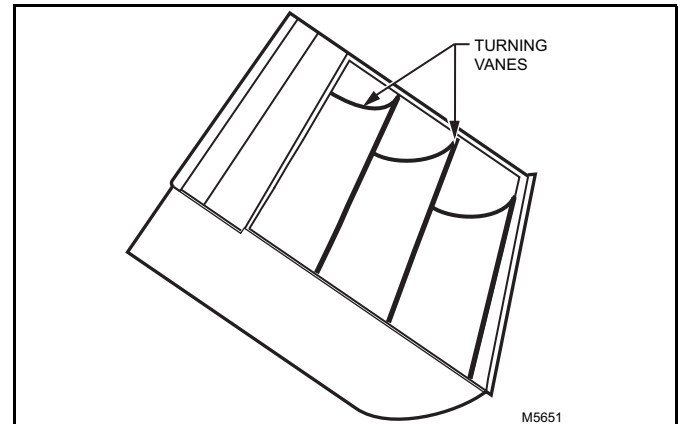

Fig. 12. Turning vanes installed in bend help distribute airflow evenly over face of media.

Offsets

If the duct connection to the furnace in a side installation allows less than 7 in. (178 mm) for mounting media air cleaner cabinet, attach an offset to the elbow. See Fig. 13.

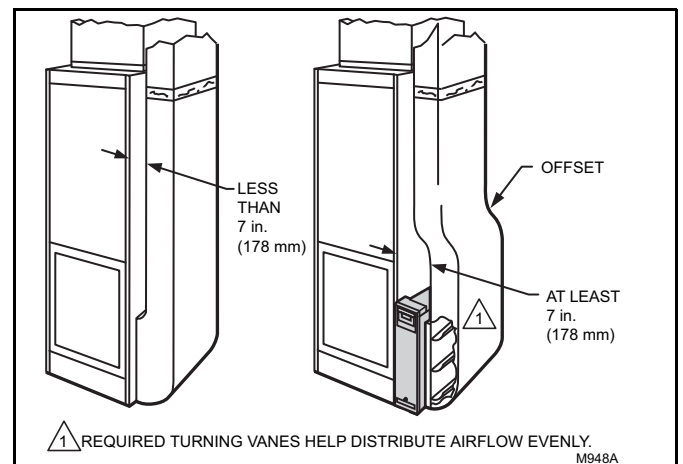

Fig. 13. Typical use of duct offset to make room for media air cleaner.

INSTALLATION AND CHECKOUT

When Installing this Product...

1. Read these instructions carefully. Failure to follow them could damage the media air filter or cause a hazardous condition.
2. Check the ratings given in the instructions and on the media air cleaner to make sure the product is suitable for your application.
3. Installer must be a trained, experienced service technician.

Remove Furnace Filter And Clean Blower Compartment

Before starting the installation, remove and discard the existing furnace filter (if used). Thoroughly clean the blower compartment. If possible, power vacuum the ductwork to remove accumulated dust in an occupied home or remove construction dirt in a new home. The media air cleaner cannot remove dirt that has settled in the blower compartment and distribution ducts.

Install The Cabinet

The following procedure describes a typical side installation on an existing highboy furnace. Alternate procedures are noted as appropriate. Other changes in installation procedures may be necessary to complete your installation.

Review The Installation Plan

Temporarily place the cabinet on the floor, oriented as it will be when installed. Insert and remove the cartridge to make sure the plan allows adequate clearance for easy removal and replacement of the cartridge.

Make sure that shop-fabricated sheet metal components, such as turning vanes, are available.

Fasten The Cabinet To The Furnace

Align the cabinet with the return air opening. Place blocks under the cabinet, as necessary, to make sure the unit sits securely. Create an opening in the furnace to match the cabinet opening. Attach the cabinet securely to the furnace. Attach the unit directly or fit a starting collar in the furnace opening. Either drill holes and fasten with sheet metal screws or rivets, or use slip joints. If you are drilling holes, use a locking pliers to help hold the unit in place during drilling.

Install Turning Vanes

Install turning vanes to help distribute air equally over the full surface of the upstream side of the media. Install them whenever an abrupt 90 degree elbow is installed directly against the media air cleaner cabinet.

Fasten Cabinet To Ductwork

Fasten side of cabinet to the ductwork using sheet-metal screws, rivets, or slip joints, as appropriate.

Connect Ductwork

Connect the vertical duct section to the elbow. If the vertical drop of the duct is less than 7 in. (178 mm) from the side of the furnace, shorten the horizontal trunk or attach an offset fitting to the elbow. See Fig. 12. When ductwork is properly aligned, connect the vertical duct to the horizontal trunk.

Seal Joints

Seal all joints in the return air system between the media air filter and the furnace to prevent dust from entering the clean airstream.

Install Filter Cartridge

Slide the filter cartridge into the cabinet, making sure the arrow on the cartridge points in the direction of air flow.

Replace access door. Insert the tab on the bottom of the door into the slot in the cabinet. Swing the door closed and press it into place.

Checkout

Visually check the installation. Make sure:

- Airflow is in the direction of the arrow on the media air filter cartridge.
- Turning vanes and transitions, if used, are properly installed.
- Joints in sheet metal between media air filter and furnace are sealed.
- All sheet metal connections are complete.
- Original furnace filter has been removed and blower compartment is cleaned.

Replace any access doors removed during the Installation or Checkout.

Run the furnace or cooling system through one complete cycle to make sure the system operates as desired.

Maintenance

The media filter must be replaced when pressure drop across the media filter reaches 0.5 in. w.c. (0.1 kPa), or at least annually. If the media air cleaner is installed downstream from an atomizing humidifier or if the installation includes both heating and cooling, more frequent replacement may be necessary. Clogged media must be replaced promptly to avoid restricting airflow and reducing efficiency of the heating-cooling system. Record the replacement date in the space provided on the replacement media filter.

LIMITED FIVE-YEAR WARRANTY

5 years from date of purchase (contact the Rheem Parts Distribution Center for more information).



Before proceeding with installation, refer to installation instructions packaged with each model, as well as complying with all Federal, State, Provincial, and Local codes, regulations, and practices.

**RHEEM
AIR CONDITIONING
DIVISION**

5600 Old Greenwood Road, Fort Smith, Arkansas 72908



"In keeping with its policy of continuous progress and product improvements, Rheem reserves the right to make changes without notice."

® U.S. Registered Trademark
© 2009
68-0304—02 M.S. Rev. 01-09



Printed in U.S.A. on recycled paper containing at least 10% post-consumer paper fibers.