

Limited Warranty

This product comes with a two (2) year limited warranty on parts. The warranty provides that a replacement will be furnished for any part of the product that fails in normal use and service during the applicable warranty period specified, in accordance with the warranty's terms. The replacement part is warranted for only the unexpired portion of the original warranty.

All parts are warranted for a period of TWO (2) YEARS after the effective date. The effective date is the date of installation if properly documented. Otherwise, it is the date of manufacture plus twenty four (24) months.

STANDARD PROVISIONS AND CONDITIONS

The following terms are common to all of PROSTOCK'S individual product warranties.

THIS WARRANTY WILL NOT APPLY: a) to defects or malfunctions resulting from failure to properly install, operate or maintain the unit in accordance with the manufacturer's printed instructions; b) to damage from abuse, accident, fire, flood, and the like; c) to parts used in connection with normal maintenance, such as cleaning or replacing air filters; d) to units that are not installed in the United States of America or Canada; e) to units that are not installed in accordance with applicable local codes, ordinances and good trade practices; or f) to defects or damage caused by the use of any attachment, accessory or component not authorized by PROSTOCK.

SHIPPING COSTS: You will be responsible for the cost of shipping warranty replacement parts from our factory to our PROSTOCK distributor and from the distributor to the location of your product. You also are responsible for any shipping cost of returning the failed part to the distributor. (If in Alaska, Hawaii, or Canada, you also must pay the shipping cost of returning the failed part to the port of entry into the continental U.S.)

SERVICE LABOR RESPONSIBILITY: This Warranty does not cover any labor expenses for service, nor for removing or reinstalling parts. All such expenses are your responsibility, unless a service labor agreement exists between you and your contractor.

HOW TO OBTAIN WARRANTY PERFORMANCE: You must promptly report any failure covered by this warranty to the installing contractor or distributor. Normally, the installing contractor from whom the unit was purchased will be able to take the necessary corrective action by obtaining through his PROSTOCK distributor any replacement parts. If the contractor is not available, simply contact any other local contractor handling PROSTOCK products.

The name and location of a local contractor can usually be found in your telephone directory or by contacting a PROSTOCK distributor. If necessary, the following PROSTOCK office can advise you of the nearest PROSTOCK distributor:

P.O. Box 17010 • Fort Smith, Arkansas 72917-7010 • (479) 648-4786 • (For CA only: (866) 251-4090)

HOWEVER, ANY REPLACEMENTS ARE MADE SUBJECT TO VALIDATION BY PROSTOCK OF IN-WARRANTY COVERAGE.

An item to be replaced must be made available in exchange for the replacement.

MISCELLANEOUS: No one is authorized to make any warranties on behalf of PROSTOCK. ANY IMPLIED WARRANTIES, INCLUDING MERCHANTABILITY OR FITNESS FOR A PARTICULAR PURPOSE, SHALL NOT EXTEND BEYOND THE APPLICABLE WARRANTY PERIODS SPECIFIED ABOVE, PROSTOCK SOLE LIABILITY WITH RESPECT TO DEFECTIVE PARTS SHALL BE AS SET FORTH IN THIS WARRANTY, AND ANY CLAIMS FOR INCIDENTAL OR CONSEQUENTIAL DAMAGES ARE EXPRESSLY EXCLUDED. Some states do not allow limitations on how long an implied warranty lasts, or for the exclusion of incidental or consequential damages, so the above limitation or exclusion may not apply to you.

This Warranty gives you specific legal rights, and you may also have other rights that vary from state to state.



P.O. Box 17010 • 3900 South Zero Street • Fort Smith, Arkansas 72917-7010
Phone: (479) 648-4786 (For CA only: (866) 251-4090)



Duct Mount Electronic Air Cleaner

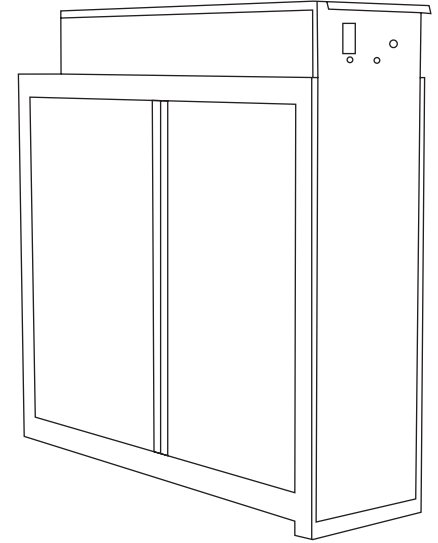

Maintenance • Operation • Installation • Warranty

84-25052-07 1400 CFM

84-25052-08 2000 CFM

84-25052-09 1400 CFM

CAUTION:
READ INSTALLATION, OPERATION, AND MAINTENANCE INSTRUCTIONS CAREFULLY FOR SAFE OPERATION.
EXERCISE EXTREME CAUTION WHEN WORKING WITH ELECTRICITY.

155587-002 02/04

Table of Contents

Introduction1
 Unit Components.....2
 Operation3
 1) Regular Dusting & “White Dust”3
 2) Ozone3
 3) High Altitude Applications4
 Maintenance of Your Electronic Air Cleaner5
 1) Washing the Cells and Pre-filter(s)5
 2) Replacing the Ionizer Wires6
 3) Cleaning the Air Flow Sensor (AFS)6
 Common Questions & Answers.....7
 Common Troubleshooting Techniques.....9
 Unit Specifications10
 Warranty.....26
HVAC INSTALLATION INSTRUCTIONS.....11
 (for use by authorized HVAC contractors only)
 Technical Specifications11
 Installation Considerations12
 Application12
 Installation Requirements12
 Air conditioning12
 Evaporative Humidifiers12
 Atomizing Humidifiers13
 Sheet Metal Installation13
 Transitions13
 Outdoor Air.....13
 Turning Vanes13
 Location Selection14
 Typical Mounting Positions15
 Mechanical Installation16
 Electrical Installation18
 System Checkout19
 Troubleshooting.....20
 Air Flow Sensor20
 Primary Circuit21
 Secondary Circuit – Ionizing-Collecting Cell22
 Secondary Circuit – Power Supply23
 Unit Diagram & Parts List25
 Warranty26

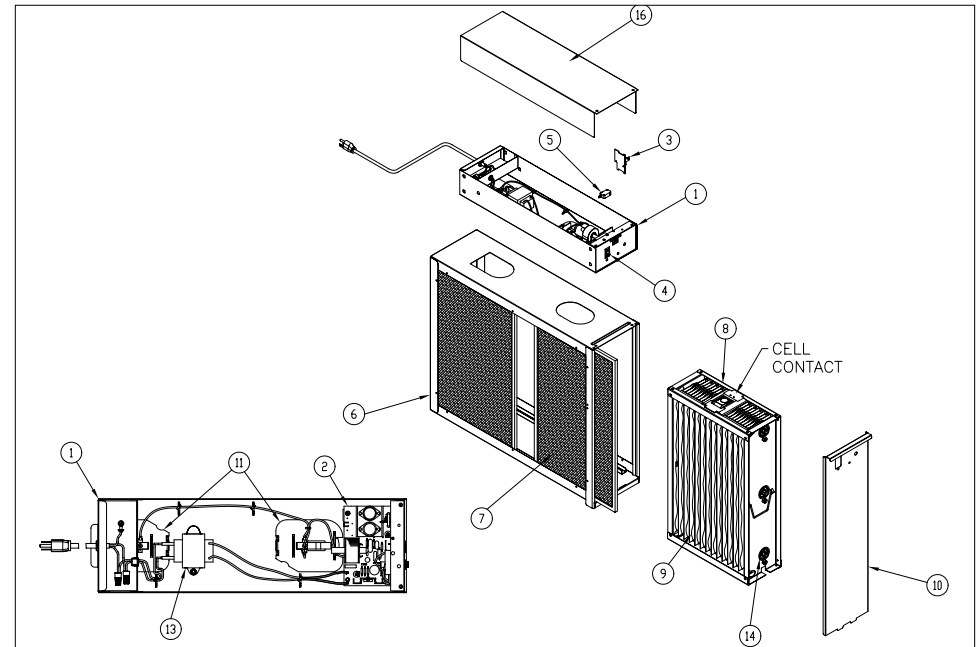

Ref. No.	Description	84-25052-07 (16" x 25")	84-25052-09 (20" x 20")	84-25052-08 (20" x 25")
1	Power Tray Assembly 120/50-60/1	45-25053-47	45-25053-62	45-25053-47
2	High Frequency Power Supply*	45-25053-49	45-25053-49	45-25053-49
3	Electronic Air Flow Sensor*	45-25053-46	45-25053-46	45-25053-46
4	On/Off switch*	45-25053-12	45-25053-12	45-25053-12
5	Interlock Switch*	45-25053-50	45-25053-63	45-25053-50
6	Cabinet Assembly	89-25053-64	89-25053-65	89-25053-66
7	Pre-Filter (2 req.)	54-25053-20	54-25053-67	54-25053-21
8	Cell, Ionizing-Collecting (2 req.)	45-25053-52	45-25053-75	45-25053-59
9	Ionizing Wire Assembly	45-25053-53 (13 req.)	45-25053-60 (10 req.)	45-25053-60 (13 req.)
10	Front Panel Assembly	89-25053-68	89-25053-70	89-25053-69
11	Contact Board Assembly (2 req.)*	45-25053-35	45-25053-35	45-25053-35
12	Charcoal filter (optional, not shown)	54-25053-36	54-25053-74	54-25053-37
13	Step-down Transformer 120V to 24VAC*	46-25053-55	46-25053-55	46-25053-55
13a	Step-down Transformer 240V to 24VAC option	46-25053-71	46-25053-71	46-25053-71
14	Insulator (6 req. per cell)	45-25053-43	45-25053-43	45-25053-43
15	Cell Key (not shown) (1 req.)	45-25053-44	45-25053-44	45-25053-44
16	Power Tray Cover	89-25053-72	89-25053-73	89-25053-72

*Component of Power Tray Assembly

10. If no voltage is present, remove the second cell. Install cell number one and measure voltage as described in step #7. If voltage is present, the second cell, which is now out of the cabinet, is shorted. Refer to COMMON TROUBLE SHOOTING TECHNIQUES (pg. 9).
11. If no voltage is present, remove both Ionizing-Collecting Cells and measure the power supply output. While depressing the safety interlock switch lever, touch the end of the high voltage probe to either the front or rear contact board assembly. The meter should read 6.2 KVDC or higher.
12. If no voltage is present, check the transformer. Set the Multimeter for reading AC voltage at 200 volt full scale and attach meter test leads to the junction of the transformer secondary leads and the circuit board. The meter should read 24 volts +/- 4 volts.
13. If there is no voltage from the transformer, replace the transformer and power supply board.

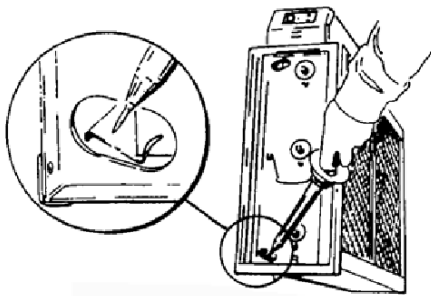

Measuring Voltage at Ionizing Collecting Cell

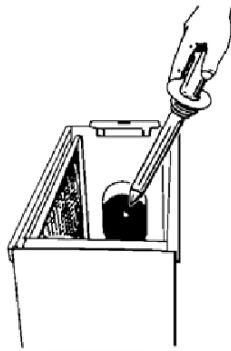

Measuring Voltage at Contact Board Assemblies

INTRODUCTION

This Electronic Air Cleaner is technically known as a two-stage electrostatic precipitator. The air cleaner is designed to remove airborne particulates, including dust, dirt, smoke, pollen, virus, spores, bacteria, and mold from indoor air.

Air movement through the unit is provided by the heating, air conditioning or ventilating system blower. As dirty air enters the air cleaner, the air passes through Metal Mesh Pre-filters. The Pre-filters prevent lint, pet hair and other large particulates from entering the air cleaner. It is important that these filters be in place to prevent excessive dirt loading of the air cleaner Ionizing-Collecting Cells. These filters extend the time interval between scheduled maintenance of the air cleaner, which allow the Ionizing-Collecting Cells to provide clean air for a longer period between washings.

The pre-filtered air then passes through a two-stage Electronic Air Cleaner. In the first stage, all airborne particulate, even submicron size, are electronically charged (positive) as they pass through the ionizer section. The ionizer field is a result of a corona discharge emanating from the fine, tightly strung wires suspended between two adjacent flat plates. In the second stage, the charged particulate passes through an intense electrical field established between alternately charged and grounded parallel collector plates. Here, the charged (positive) particulate is attracted to the ground (negative) plates and removed from the air stream.

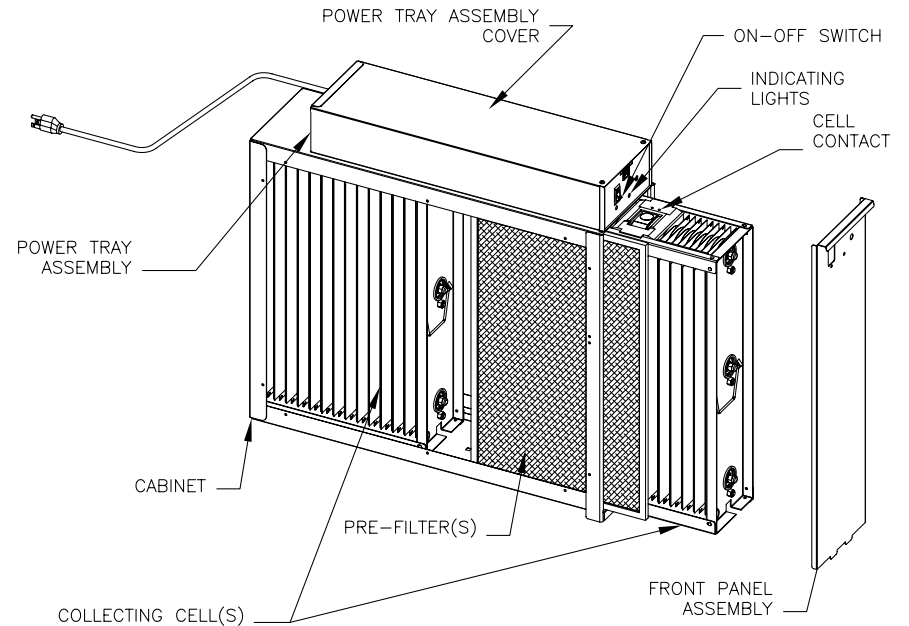

Cabinet

Mounts to existing ductwork; houses the Ionizing-Collecting Cells and Pre-filters.

Ionizing-Collecting Cells

Collect the dust, dirt and other particulates in the air. They contain the ionizing and collecting sections. The cells must be installed with the ionizing wires on the air intake side. A spring contact is located on the top of each cell and must be in the position to make contact with the contact board assemblies on the bottom of the Power Tray Assembly.

Pre-filters

Trap large particulates before they enter the Ionizing-Collecting Cells Power Tray Assembly.

Power Tray Assembly

Contains the indicating lights, solid state power supply, contact boards and electrical controls including the ON/OFF switch and safety interlock switch. A power cord at the rear of the 120 volt Power Tray allows the unit to be connected to a standard 120 volt outlet. A wiring compartment is provided on all models at the rear of the Power Tray allowing the option to permanently wire the unit directly to the HVAC System Control.

Air Flow Sensor (AFS)

Controls the operation of the unit by sensing the movement of air within the duct. This helps to reduce power usage.

The AFS is designed to provide an efficient and reliable method of controlling the operation of the air cleaner when the dealer is unable to wire the unit directly into the HVAC System Blower Control Circuit. The AFS utilizes a thermistor, when electrically powered, heats up to approximately 130° F. The AFS stabilizes at this temperature and while the HVAC System Blower is in operation, air flows through the ductwork, creating a vacuum effect that pulls cooler air over the hot surface of the thermistor. This air movement cools down the thermistor which allows the AFS to register that the HVAC System blower is moving air and the Electronic Air Cleaner must be powered to provide air cleaning.

Air Cleaner Model Identification

The model number and part number for your Electronic Air Cleaner can be found on the data label located on the inside of the Front Panel Assembly.

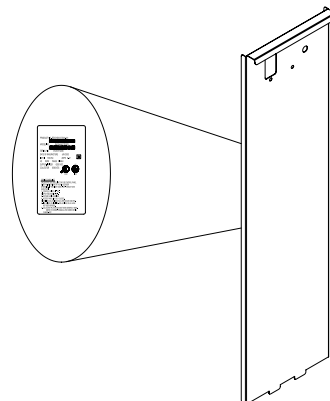
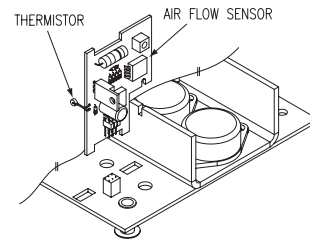
**SECONDARY CIRCUIT POWER SUPPLY**

If the Red CELL ENERGIZED light remains out with the Ionizing-Collecting Cells removed from the cabinet, the power supply is defective. Specific problems in the Power Tray Assembly can be isolated by using a Multimeter and High Voltage Probe to check the output voltages.

To check the secondary circuit, a high voltage meter is required. See the section entitled RECOMMENDED SERVICE TOOLS (pg. 20). To check for proper operation, it is imperative that the procedure be followed as outlined below:

1. Make sure the HVAC system is operating, the air cleaner ON/OFF switch is ON, and air cleaner input voltage is correct (120V, 50-60Hz for 120V units and 240V, 50-60Hz for 240V units).
2. Remove Front Panel Assembly from air cleaner.
3. Remove Power Tray Assembly Cover.
4. Check the high voltage contact board assembly for damage or carbon tracking.

NOTE: The cell contacts must be visually checked for corrosion, excessive dirt build up, and electrical arc tracking (Carbon path from stainless steel spring to grounded metal). Clean or replace as required.

5. Replace both Ionizing-Collecting Cells in the air cleaner cabinet.
6. Make test connections from the High Voltage Probe to the Multimeter in accordance with the probe's instruction manual. The Multimeter should be set for reading DC voltage at 20 volt full scale.
7. Attach the High Voltage Probe ground lead to the air cleaner cabinet. While depressing the safety interlock switch lever, touch the ionizer wire support with end of the High Voltage Probe. The meter reading should be 6.2 kVDC + .2 kVDC.
8. If no voltage is measured, remove the first Ionizing-Collecting cell and check the second cell by repeating step #7. The meter should read 6.2 kVDC + .2 kVDC.
9. If proper voltage is measured, the first cell is shorted. Refer to COMMON TROUBLESHOOTING TECHNIQUES (pg. 9).

For Qualified HVAC
Installer Only

SECONDARY CIRCUIT

IONIZING-COLLECTING CELL

The cells are electrically energized through a contact terminal located at the top center of each cell. The ionizing wires and alternating collector plates are electrically charged while the interleaving plates are grounded.

If the space between the charged and grounded plates is bridged with conductive or semi-conductive material, a short circuit develops. The bridging or short may be caused by damaged plates, or foreign material lodged between/on the components. Since the cell should be periodically removed from the unit to wash away collected dirt, it is susceptible to physical damage. The cell also contains the ionizing wires, which have been designed due to their function with minimal structure support and are susceptible to breakage. Short circuit issues related to dirty or damaged Ionizing-Collecting Cells are readily identified by the lack of illumination of the Red CELL ENERGIZED light and quickly identified and isolated by a simple procedure.

To determine if a short circuit condition exists in one or both Ionizing-Collecting Cell(s), turn the Electronic Air Cleaner OFF. Remove both Ionizer-Collecting Cells from the cabinet. Re-position the Front Panel Assembly to the cabinet, turn ON/OFF switch ON and ensure HVAC system blower is operating.

The Green INPUT POWER light should illuminate. If the Red CELL ENERGIZED light illuminates, an electrical short circuit exists in one or both of the Ionizing-Collecting Cells. Replace the cells, one at a time, to determine which cell has the short circuit. The Red CELL ENERGIZED light will not illuminate if a short circuit condition is detected.

Most short circuit troubles in the cell can be visually detected and corrected. Refer to COMMON TROUBLESHOOTING TECHNIQUES (pg. 9).

NOTE: The Ionizing-Collecting Cells are not designed for field repair. Ionizing wires and insulators can be field replaced; however, it is not recommended that you attempt to replace other cell components (i.e. collecting plates, end plates, ionizer wire supports).

Dusting and "White Dust"

Your new Electronic Air Cleaner will efficiently clean and filter your household air. It will not eliminate the need for regular dusting of your furniture and belongings. Duct-mounted air cleaners can only clean air that reaches the air cleaner. Therefore, if the particulates are not being carried to the air cleaner in the air stream, the air cleaner cannot remove them from your home.

Occasionally a "white dust" may be noticed in bedrooms or newly furnished rooms. This is mainly composed of lint which, because it is heavier than other particulates, settles before it reaches your unit. This "white dust" is not mixed with airborne dirt particles, therefore, it is clean and has no staining or soiling properties. Running the furnace blower continuously, day and night, will help reduce this from occurring.

Ozone

Under normal operating conditions, all Electronic Air Cleaners produce minute quantities of ozone as an incidental by-product. In fact, all electronic products, such as televisions, cordless telephones and refrigerators, produce some amount of ozone. The average homeowner can detect the smell of ozone concentrations as low as 25 to 100 ppb (parts per billion). The design of this unit has been tested and ozone production is approximately half of the published permissible limits established by the Environmental Protection Agency. These limits recommend that the concentration of indoor ozone not exceed 50 ppb. Ozone is not harmful in these concentrations. In fact, the ozone level in major cities can sometimes reach as high as 100 ppb on a summer day. The addition of optional charcoal after-filters can help reduce the smell of ozone generated by the air cleaner.

Normally, a new unit will produce more ozone than one that has been in operation for several weeks. This is due to sharp corners or manufacturing burrs on the Ionizing-Collecting Cell Plates and is normal. As the Electronic Air Cleaner arcs and zaps, the voltage is vaporizing these areas and tends to round them off. This is part of the breaking-in period of ownership and the issue is self-correcting. Also, high-altitude locations can be more susceptible to noticing the presence of ozone.

An Ionizing-Collecting Cell that has been damaged or bent (the designed spacing between electrically charged and ground components has been decreased) may also produce an abnormal amount of ozone.

Circuit Diagram

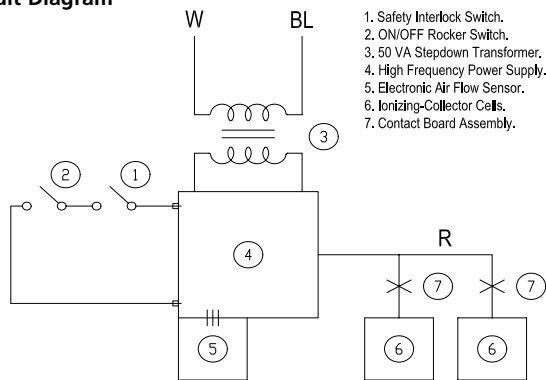

High Altitude Operation

Because the air is less dense at higher altitudes, there is a possibility of nuisance arcing in the Electronic Air Cleaner. The homeowner can quickly and easily correct this condition.

1. Make sure the HVAC System Blower is not operating, the ON/OFF switch is in OFF position and the circuit breaker is turned OFF or input power cord is disconnected.
2. Remove the Front Panel Assembly.
3. Remove the cover from the Power Tray Assembly by removing the two screws on top of unit. (The entire Power Tray Assembly may be removed from the cabinet by removing two screws from inside the cabinet.)
4. Locate the jumper terminal.
5. With a pair of needle nose pliers, carefully relocate the jumper settings from HIGH to MED. Ensure that the jumper is firmly seated in the terminal.
6. Replace the Power Tray Cover and secure it with two screws.
7. Replace the Front Panel Assembly, turn circuit breaker ON, reconnect input power cord and turn ON/OFF switch ON.

This procedure will slightly reduce the output voltage, minimize arcing and reduce ozone production. If the condition does not improve, repeat the above procedure and move the jumper setting from MED (M) to LOW (L).

This unit is produced at the factory with the jumpers set in the HIGH (H) position. However, the output voltage may be lowered in any situation where the unit is arcing excessively or there is excessive ozone.

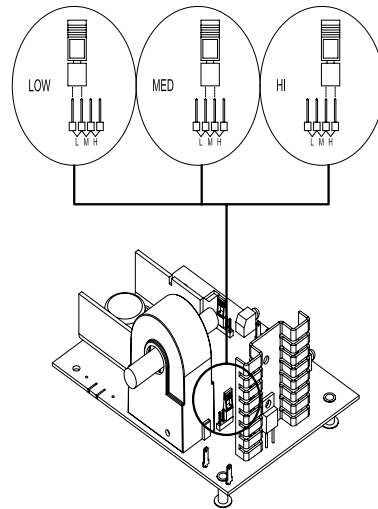

PRIMARY CIRCUIT WITH HVAC SYSTEM BLOWER OPERATING

- If there is no supply line voltage at the transformer input connections, correct the fault at the dedicated power source or HVAC system power source.
- If there is supply line voltage at the transformer input connections and no output voltage (24 volts nominal), the transformer is defective and must be replaced.
- If there is transformer output voltage (24 volts nominal) and no output voltage from the ON/OFF switch, the outage can be located by checking operation of the safety interlock switch and the interconnecting wiring with a Multimeter. Refer to Circuit Diagram, (pg. 22) to check operation of the switches.

PRIMARY CIRCUIT WITH HVAC SYSTEM BLOWER NOT OPERATING

Follow these steps to test for proper operation of the Power Supply Board, ON/ OFF Switch, and Safety Interlock Switch.

1. Ensure that the circuit controlling the HVAC system blower is in the OFF position, and input power to the air cleaner is disconnected.
2. The power supply board has a built-in internal fuse to protect the 24V transformer. The fuse can be checked visually by inspection. If the fine wire inside of the fuse is broken, a fault exists in the 24 circuit. Do NOT replace this fuse. The entire Power Supply Assembly must be replaced. The purpose of the fuse is not to protect the power supply board, but to function as a troubleshooting feature of the product and to protect the transformer from damage.
3. If the fuse is NOT blown, check the ON/OFF switch and safety interlock switch for proper engagement and operation. This can be completed using a Multimeter with an OHM scale capable of reading 1.0 ohm.
4. Remove the fuse. Connect one Multimeter test lead to the test pin hole (J9) located directly beside the wire that connects the ON/OFF switch to the power supply board. Connect the other Multimeter test lead to the fuse connection nearest the front panel
5. Turn the ON/OFF switch to the ON position and depress the safety interlock switch. The Multimeter should have the capability of reading levels as low as 1.0 ohm. Multimeter reading of 1.0 ohm or less indicates correct operation of the ON/OFF switch and the safety interlock switch.
6. If the Multimeter ohm reading is greater than 1.0 ohm, begin the process of elimination by moving the Multimeter test lead from the test pin hole (J9) to the safety interlock switch terminal with the blue wire lead. Depress the safety interlock switch. If the reading on the meter is greater than 1.0 ohm, the safety interlock switch is defective and must be replaced. If the reading on the meter is less than 1.0 ohm, the ON/OFF switch is defective and must be replaced.

**For Qualified HVAC
Installer Only**

TROUBLESHOOTING

CAUTION:

- These procedures must be performed by a qualified HVAC technician or electrician.
- Risk of personal injury or death could occur by attempting to troubleshoot or repair this unit by untrained persons.
- Exercise the usual precautions when working with high voltage.
- When the circuit has been de-energized, always discharge any residual current in the secondary circuit with an insulated handle screwdriver.
- Always ground power supply and Ionizing-Collecting cell when bench testing.

RECOMMENDED SERVICE TOOLS

- Screwdriver, 8" common with insulated handle (plastic)
- Screwdrivers, Phillips #1 and # 2 with insulated handle (plastic)
- Needle Nose Pliers with insulated handles (plastic)
- Multimeter
- High Voltage Probe

INDICATION OF ELECTRICAL TROUBLE

The air cleaner is equipped with a Red CELL ENERGIZED light for indicating proper unit operation. When the unit is in normal operation (with the HVAC system blower running, Front Panel Assembly in place and ON/OFF switch in the ON position) and the Red CELL ENERGIZED light is not illuminated, the problem is a shorted secondary circuit or Air Flow Sensor fault. Although failure of the indicating light itself should not be overlooked, this condition is unusual.

AIR FLOW SENSOR (AFS) TROUBLESHOOTING

The following procedure must be performed by an authorized HVAC contractor. Failure to do so may expose an individual to serious personal injury or death.

1. Make sure the HVAC system blower is not operating, the ON/OFF switch is in OFF position and the circuit breaker is turned OFF or input power cord is disconnected.
2. Remove the Front Panel Assembly.
3. Remove the cover from the Power Tray Assembly by removing the two screws on top of unit.
4. Locate the AFS, a small circuit board with a small gray disc connected to the board by two silver wires (see Air Flow Sensor (AFS) pg. 2). Carefully bend the thermistor (small gray disc) wire leads so the thermistor is located in the center of the 3/16" diameter hole in the Power Tray Assembly and approximately 1/8" from the inside edge of the Power Tray Assembly front.

WASHING IONIZING- COLLECTING CELLS AND PRE-FILTERS

Regular washing of the Ionizing-Collecting Cells is necessary to ensure proper performance.

A thorough washing once every two months will be adequate for most installations. More frequent washing (once a month) may be necessary with some installations (new home for example) where there is new carpeting, plaster dust or excessive cigarette smoke.

NOTICE: Handle Ionizing-Collecting Cells with care as plates can be sharp and cause injury if not handled properly.

To Remove the Ionizing-Collecting Cells and Pre-filters from the Air Cleaner:

1. Turn air cleaner ON/OFF switch to OFF position. Wait 15 seconds. Remove Front Panel Assembly.
2. Carefully remove the Ionizing-Collecting Cell(s) and Pre-filter(s) and set aside in a safe place.
3. Do not drop the Ionizing-Collecting Cell. This can cause damage to the cell plates or ionizing wires which results in excessive arcing and poor performance.

To Wash Ionizing-Collecting Cells and Pre-filters:

We suggest you follow the instructions below to properly and thoroughly clean your Ionizing-Collecting Cells.

1. Place enough hot water in a utility tub to cover the first cell. Dissolve 2-4 oz. of granulated automatic dishwasher detergent (NOT laundry detergent) in the water.
2. Allow the cell to soak for 30 minutes. Agitate it up and down in the solution until it appears clean and remove.
3. Repeat with second cell (if applicable).
4. Agitate the Pre-filters up and down in the solution until they appear clean.
5. With a hose, rinse the Ionizing-Collecting Cells and Pre-filters. The hose should be held about 10" from the cell plates and at a slight angle for maximum cleaning results. Be careful not to spray the ionizing wires directly with the hose as the water pressure can cause the wire(s) to stretch and break. The cell frame should be thoroughly rinsed along the edges to dislodge any trapped lint or dirt. Carefully wipe a damp cloth or sandpaper (not emery cloth) along the ionizing wires.
6. Stand Ionizing-Collecting Cells and Pre-filters in upright position and allow to dry two hours. You may experience a slight discoloration of the aluminum collector cell plates after washing. This is a normal chemical reaction between the aluminum and detergent and will not harm your unit or affect its performance.

To Replace Cells in the Air Cleaner:

1. Replace Pre-filter and Ionizing-Collecting Cells in cabinet. Check that airflow arrow on Cells point in same direction as air flows through the duct. (If you have to force the cell past the positioning screw in the cabinet bottom, the cell is probably in the incorrect position.)
2. Replace Front Panel Assembly (engage tabs on lower edge of door into slots in cabinet). Carefully close the Panel.
3. Turn air cleaner ON/OFF switch to ON position.

REPLACING THE IONIZING WIRES

Instances of the Ionizing Wires breaking are minimal due to the constant tension design and fixed location of the Ionizing Wire supports. When an Ionizing Wire breaks, the efficiency of the Electronic Air Cleaner will decrease slightly. However, the unit will continue to operate with a broken Ionizing Wire as long as the broken wire has not caused a short in the secondary circuit of the unit. Remove all loose and broken wires as soon as they are identified.

We recommend contacting a qualified HVAC contractor for replacement parts and/or servicing. Ionizing Wires are supplied in a coiled spring configuration, with a clinch nut on each end of the wire. Replacement requires a pair of needle nose pliers. Exercise caution in removing any broken wires in the Ionizing-Collecting Cell. The removal of broken wires will prevent accidental shorting of the cell and reduce the need for further maintenance.

Use the following procedure when replacing an Ionizing Wire:

1. Turn Air Cleaner ON/OFF switch to OFF position. Wait 15 seconds. Remove the Front Panel Assembly and remove the Ionizing-Collecting Cells from the unit.
2. Carefully remove all remains of the broken wire from the cell.
3. Grip the new wire at each end with your thumb and index finger. While stretching the wire to approximately 6", allow one end of the wire to uncoil between your thumb and index finger.
4. Place one end of the wire in the slot of the stainless steel wire support located on the Ionizing-Collecting Cell as viewed from the front of the cell. This support is partially covered by the cell brace in front of the support.
5. Grip the other end of the Ionizing Wire with needle nose pliers and insert the terminated end of the wire into the slot in the wire support on the opposite end of the Ionizing-Collecting Cell.
6. The wire should have sufficient tension to be self supporting and remain suspended between the slots in the wire supports.

CLEANING THE AIR FLOW SENSOR

If the air cleaner is installed in a location that is dusty and dirty, the sensor (thermistor) on the AFS can become coated with dirt and lint. This coating can insulate the AFS and keep it from operating properly. To clean the thermistor, turn the unit OFF, dip a cotton swab in rubbing alcohol and carefully insert into the 3/16" diameter hole located on the front right hand side of the Power Tray Assembly (when facing the unit). Carefully twirl the cotton swab between your fingers, making sure the tip is lightly in contact with the gray disc (thermistor), cleaning the insulating coating from the thermistor.

SYSTEM CHECKOUT

WARNING: The following procedures must be conducted by a qualified HVAC contractor or repair person ONLY. These procedures will expose hazardous electrically energized charged components. Disconnect power between checks and proceed carefully.

1. The HVAC system blower should be turned OFF.
2. Switch the ON/OFF rocker switch to the ON position. The bright red segment of the rocker switch should be visible.
3. Inspect both the Green INPUT POWER light and the Red CELL ENERGIZED light:

System With Air Cleaner INPUT POWER From Dedicated Power Source

- The Green INPUT POWER light should illuminate and remain illuminated.
- The Red CELL ENERGIZED light should illuminate and should go out in approximately 20 to 60 seconds. This is the normal time for the electronic Air Flow Sensor to complete its stabilization period. The Red light will come back on when the HVAC system blower begins to operate. See the section entitled AIR FLOW SENSOR pg. 2, for more information.

System With Air Cleaner INPUT POWER From HVAC System

- Neither Green INPUT POWER light nor Red CELL ENERGIZED light should illuminate.

4. Wait approximately one minute and turn the HVAC system blower ON. Most thermostats have a setting that will allow you to operate the blower manually. If not, set the thermostat so that either hot or cold air begins to flow through the duct work.

System With Air Cleaner INPUT POWER From Dedicated Power Source

- The Green INPUT POWER light should remain illuminated.
- The Red CELL ENERGIZED light should illuminate within approximately 20 to 60 seconds, and remain illuminated while the HVAC system blower is in operation.

System With Air Cleaner INPUT POWER From HVAC System

- The Green INPUT POWER light should illuminate and remain illuminated.
- The Red CELL ENERGIZED light should illuminate within approximately 20 to 60 seconds and remain illuminated while the HVAC system blower is in operation.

5. Check to make sure that the Red CELL ENERGIZED light goes out with the following conditions:

- Front Panel Assembly is removed
- ON/OFF switch is switched to the OFF position
- HVAC system blower is not running

ELECTRICAL INSTALLATION

CAUTION:

If the Electronic Air Cleaner is wired directly to the integrated accessory control on the furnace, it is imperative that the ampere rating of the control be sufficient to handle the current required by the air cleaner. All wiring shall be performed in accordance with the National Electric Code.

CAUTION:

Do not wire the Electronic Air Cleaner directly to a multiple speed blower motor. Wiring to a multiple speed blower motor will damage the Air Cleaner power supply and void the warranty.

Read the instructions in the furnace installation manual carefully before attempting installation or operation of the Electronic Air Cleaner. Failure to follow these instructions may result in an improper installation and therefore void the HVAC system and/or Air Cleaner warranty.

PROCEDURE FOR WIRING THE ELECTRONIC AIR CLEANER TO INPUT POWER SOURCE

A power cord is provided on the 120 volt model for connection to a standard 120V receptacle. If the unit is to be permanently connected to the furnace control panel, a wiring compartment (with a knockout hole) is located at the rear of the Power Tray Assembly. It is accessible by removing the Power Tray Cover.

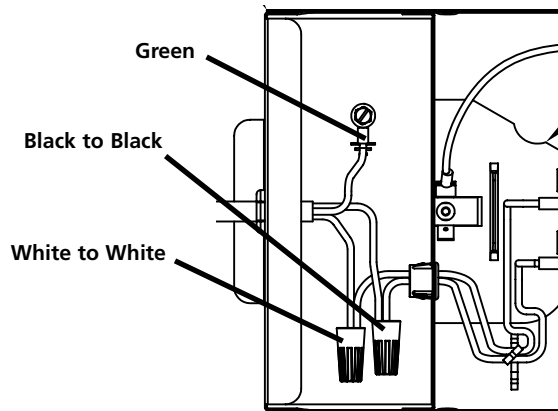

COMMON QUESTIONS AND ANSWERS

- Q. Why isn't my Electronic Air Cleaner cleaning my air?
- A. The air cleaner is most likely working just like it was designed. However, many factors can affect the performance of the unit. Are air return registers located in the ceiling? If so, it will be difficult for the air flow to carry heavier particulates to the air cleaner. If the dirt does not get to the air cleaner, it cannot be removed from the air. Are both the Red and Green indicating lights illuminated? If not, the unit may be in need of servicing.
- Q. It still isn't cleaning my air the way I want it to. What can I do?
- A. It is recommended that you operate the HVAC system continuously so that the air movement will carry the dirt to the air cleaner where it can be collected. Unfortunately, there will always be some dirt that is left behind on the appliances, furniture, etc. Regular dusting is recommended to stir up these pockets of dust so that they can enter the air stream and be removed by the Electronic Air Cleaner.
- Q. When I turn on my Electronic Air Cleaner, the lights come on for a couple of seconds and then turn off. The air cleaner isn't working!
- A. The air cleaner is operating properly as long as both the Red and Green indicating lights are illuminated. Try turning the HVAC blower ON and then turning the Electronic Air Cleaner ON. This should solve the problem.
- Q. What is the zapping noise I am hearing from my unit? Should I be concerned?
- A. The zapping or popping noise that you are hearing is the sound of larger particles being "vaporized" by the Ionizing-Collecting Cell. This is normal and is no cause for alarm. As your HVAC system blower moves the air through the ductwork and allows the Electronic Air Cleaner to clean the air, the noise will diminish. However, there will always be instances when larger particles enter the Ionizing-Collecting Cell, and are "vaporized".
- Q. Should I hear this zapping noise all the time?
- A. All Electronic Air Cleaners will occasionally zap or pop as larger particles pass through the Ionizing-Collecting Cells. However, if the sound is constant or is repetitive in nature, then a large particle may have become lodged in the Ionizing-Collecting cell and may require removal by cleaning. If cleaning the Ionizing-Collecting Cell does not stop the noise and/or there are no large particles trapped in the Ionizing-Collecting Cell, then the cause could be a broken/loose ionizing wire, bent collector plate or other mechanical fault.

- Q. What if I no longer hear any popping or zapping noises coming from my unit? Is it still cleaning the air?
- A. If the zapping noises stop and the air cleaner is not in need of servicing, then one of two situations has occurred. First, the Electronic Air Cleaner has successfully removed all larger particles from the air and is cleaning microscopic particles which do not cause the zapping noises. Second, the HVAC system blower is not operating and air is not flowing through the ductwork. The Electronic Air Cleaner cannot remove particles if the air stream is not moving.
- Q. I lost power to my home during a storm. Should I worry about the Electronic Air Cleaner ?
- A. The most common problem associated with power outages is the Electronic Air Cleaner will not turn on properly after power is restored. If the Green INPUT POWER indicating light is illuminated, and the Red CELL ENERGIZED indicating light is illuminated while the HVAC system blower is operating, the unit is operating properly. To reset the Electronic Air Cleaner, turn the HVAC system blower OFF, turn air cleaner OFF, wait one minute, turn air cleaner ON, and then turn HVAC system blower ON. If the Red and Green lights do NOT come on while the HVAC system blower is in operation, after a storm, the power supply in the Electronic Air Cleaner may be short circuited. Contact your local HVAC contractor for further assistance.
- Q. My installer told me to keep my HVAC system blower running all the time, but I don't want to increase my power bill. What should I do?
- A. It is recommended that you keep your HVAC system blower operating all the time to achieve the maximum air cleaning efficiency of the Electronic Air Cleaner. This will allow the Electronic Air Cleaner to do what it is designed to do, which is clean the air. Remember that if the air does not reach the air cleaner, it cannot be cleaned. On average, your Electronic Air Cleaner will use the same amount of electricity as a 55W light bulb. The energy usage of the HVAC system blower will depend on the age and size of your system, energy costs in your regional location and other variables.

The best solution is to operate the HVAC system blower in a continuous mode for a month or two, estimate annual energy costs, and base your final decision with what you feel most comfortable.

NOTE: The following is a typical installation of the air cleaner on a highboy furnace. You may have to alter the installation to fit your particular application.

1. Locate the cabinet in the cold air return duct such that all of the return air flows through the unit. If the furnace and air cleaner openings are different, use a transition.
2. Mounting holes are provided in the Air Cleaner cabinet for ductwork attachment. The .140" diameter holes are sized for #8 sheet metal screws, or 1/8" rivets. If the adjoining ductwork is flanged, install the screws with the screw heads inside the cabinet to prevent damage to the Air Cleaner Pre-filters and optional Charcoal After-Filters during removal and installation during scheduled maintenance.
3. After the cabinet has been mounted, seal seams air tight with duct tape or caulking.

ATTENTION: Be especially careful not to cover the Air Flow Sensor orifice when sealing the air cleaner and ductwork. This 3/16" diameter hole is located in the front of the Power Tray Assembly.

4. Refer to the section entitled DIRECTION OF AIR FLOW - Confirm correct airflow direction.
5. Install Power Tray Assembly onto the cabinet.
6. Install Pre-filters and Ionizing-Collecting Cells into cabinet.
7. Install unit's Front Panel Assembly onto cabinet.

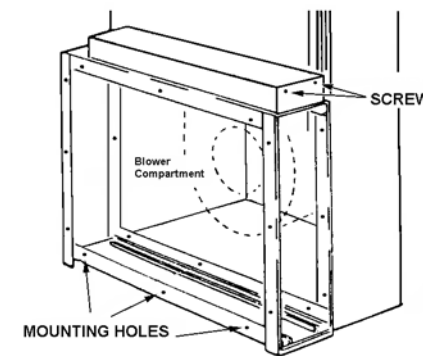

INSTALLATION

CAUTION:

Only a trained, experienced serviceman should install this Electronic Air Cleaner. The Front Panel Assembly, Power Tray Assembly, Ionizing-Collecting Cells and Pre-filters should be removed before installation. To remove the Power Tray Assembly, remove the two (2) screws from inside the top front of the cabinet. Keep this hardware for re-installation of the Power Tray Assembly after the air cleaner installation is completed and before operation. A thorough check-out of the unit installation should be completed before operation of the air cleaner.

Prior to installing this Electronic Air Cleaner:

1. Read instructions carefully for safe operation. Failure to follow instructions can damage the product or cause a hazardous condition and may result in physical harm.
2. Check the ratings stated on the product data label to make sure it is suitable for your application.
3. Select a location for the air cleaner.
4. Remove the old furnace filter and discard.
5. The air cleaner cannot remove existing dirt from the blower and ducts. Clean the area thoroughly before you begin installation.
6. Remove unit's Front Panel Assembly, and slide the Pre-filters and Ionizing-Collecting Cells out of the cabinet. Remove the Power Tray Assembly and place ALL components safely aside. Also, remove and discard cardboard shipping inserts from inside Front Panel Assembly and bottom of cabinet.

PHYSICAL INSTALLATION OF THE AIR CLEANER

This Electronic Air Cleaner can be installed in any position, except with the Front Panel Assembly facing UP or DOWN. The section TYPICAL MOUNTING POSITIONS illustrates examples of proper air cleaner mounting with a variety of furnace installations.

Common Troubleshooting Techniques

SYMPTOM	POSSIBLE CAUSES	CORRECTIVE ACTION
Rapid Arcing or Zapping	Broken or loose ionizing wire (s)	Remove broken or loose wire and replace with new wire
	Dirty Ionizing-Collecting Cell	Clean the Ionizing-Collecting Cell
	Damaged or bent collector plates	Straighten plates with needle nose pliers or replace entire Ionizing-Collecting Cell
	Dirty insulator caps on Ionizing-Collecting Cell	Clean with warm soapy water and rinse well
Excessive Ozone Smell	Air cleaner is wired directly to a 120 volt power source	Clean Air Flow Sensor
	Loose high voltage connections	Rewire Air Cleaner to the HVAC system blower by qualified HVAC contractor
Radio or Television Interference	Poor electrical ground	Uncommon occurrence- check for good common ground for air cleaner
Hissing or Sizzling Noise	Poor electrical contact in the secondary electrical circuit	Ensure that there is a good connection between the top of the Ionizing-Collecting Cell and the bottom of the contact board Contact HVAC contractor
Green LED Light is not On	No power available	Reset circuit breaker Replace fuse
	Loose wiring at ON/OFF switch	Check for secure connection
	Defective ON/OFF switch	Replace ON/OFF switch
	ON/OFF switch not in ON position	Turn the unit ON
Red LED Light is not On	Loose wiring within power pack assembly	Check for secure connections Contact HVAC contractor
	Broken or shorted electrical component	Contact HVAC contractor
	Excessive dirt build up on ionizing wires	Clean wires with alcohol and allow to dry thoroughly before turning the unit ON
	Contact board assemblies are corroded or carbonized	Replace contact board assembly
	Broken ionizing wire	Remove broken wire and replace with new wire
	Dirty Ionizing-Collecting Cell	Clean the Ionizing-Collecting Cell
	Foreign object located between collector plates	Remove object from Ionizing-Collecting Cell
	Damaged or bent collector plates	Straighten plates with needle nose pliers or replace entire Ionizing-Collecting Cell
	Insulators are corroded or carbonized	Replace insulators or Ionizing-Collecting Cell

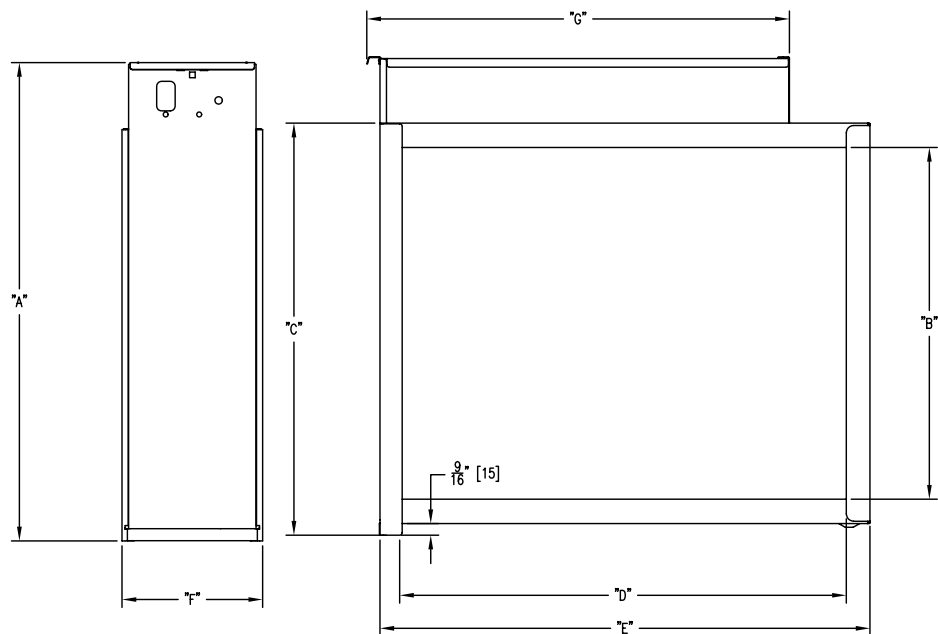

MODEL	"A"		"B"		"C"		"D"		"E"		"F"		"G"	
	IN.	MM	IN.	MM	IN.	MM	IN.	MM	IN.	MM	IN.	MM	IN.	MM
84-25052-08	24- $\frac{1}{4}$	616	17- $\frac{7}{8}$	454	20- $\frac{29}{32}$	531	22- $\frac{1}{2}$	572	24- $\frac{7}{8}$	632	7- $\frac{1}{8}$	181	21- $\frac{7}{16}$	545
84-25052-07	20- $\frac{1}{4}$	514	13- $\frac{7}{8}$	352	16- $\frac{29}{32}$	429	22- $\frac{1}{2}$	572	24- $\frac{7}{8}$	632	7- $\frac{1}{8}$	181	21- $\frac{7}{16}$	545
84-25052-09	24- $\frac{1}{4}$	616	17- $\frac{7}{8}$	454	20- $\frac{29}{32}$	531	19	483	21- $\frac{3}{8}$	543	7- $\frac{1}{8}$	181	18- $\frac{5}{8}$	473

TYPICAL MOUNTING POSITIONS

(Air cleaner shown shaded in illustrations)

WARNING

Before making changes to a HVAC system that may affect the ventilation of fuel-burning appliances, contact your heating contractor.

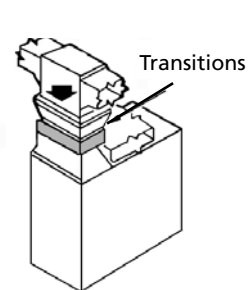

Basement Furnace (Lowboy) -Mounted horizontally in return plenum- just above the furnace.

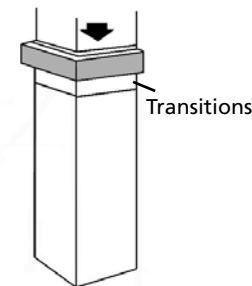

Counterflow Furnace- Mounted horizontally in return duct- just above the furnace.

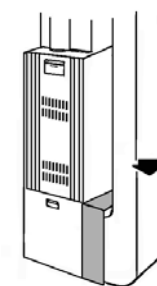

Space Saver Furnace (Highboy)- Side installation. Mounted vertically, where return air enters side inlet of furnace.

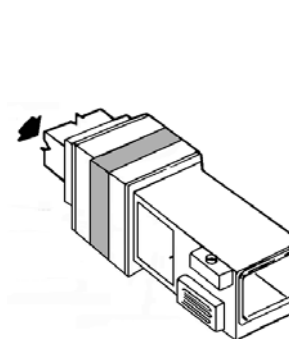

Horizontal Furnace- Mounted vertically in return duct as close to the furnace as possible.

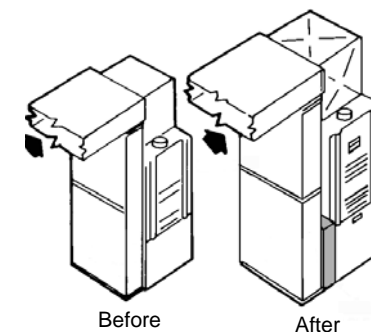

Offset Installation- If there is less than 7-in. for mounting the air cleaner between the duct and the furnace, move the return air drop.

LOCATION SELECTION

Remember to select a location that is readily accessible for periodic inspection and cleaning of the the Pre-filters and Ionizing-Collecting Cells. Allow a minimum of 24" clearance in front and 12" clearance above the air cleaner for component removal and service space.

DIRECTION OF AIRFLOW THROUGH THE AIR CLEANER

For left to right airflow:

This air cleaner is factory set for left to right airflow when you are facing the Front Panel Assembly.

For right to left airflow:

1. Remove the Pre-filters and Ionizing Collecting Cells from the cabinet. A plastic positioning spacer is located inside the bottom of the cabinet. This spacer is secured to the cabinet by a #6 Phillips drive screw to assure installation of the Cells in the correct position with respect to air flow.
2. Remove the screw and reposition the spacer in the alternate hole in the bottom of the cabinet.
3. Replace the screw to ensure the plastic spacer is not accidentally dislodged during normal maintenance. The spacer must be installed in the hole provided nearest to the air leaving side of the cabinet.
4. Remove the Ionizing-Collecting Cell handle and re-attach to the opposite end of the cell(s). Turn Cells around, reversing their orientation and replace in cabinet and replace Pre-filters on the air entering side of the air cleaner. The directional arrows on the cell end plates must point in the direction of airflow.

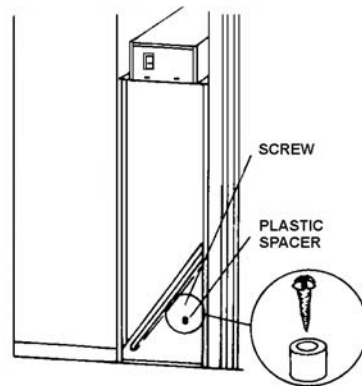

The following section is to be used by a qualified HVAC contractor or installer ONLY.

These procedures are not to be attempted by any person not qualified to work with high voltage or familiar with the installation of this type of air cleaner. Seller cannot be held responsible for any injury or damage by any person not qualified to install this product.

Technical Specifications

Model	84-25052-07	84-25052-09	8425052-08
Size	(16x25)	(20x20)	(20x25)
Maximum Rated Airflow	1400 CFM (2380m/hr)	1400 CFM (2380m/hr)	2000 CFM (3400m/hr)
Maximum Pressure Drop	.11 inch w.g. @1400 CFM	.11 inch w.g. @1400 CFM	.14 inch w.g. @2000 CFM
Cell Weight (2 Cells in ea. unit)	10 lbs ea. (4.5 kg)	9 lbs ea. (4.1 kg)	12 lbs ea. (5.5 kg)
Unit Weight	32 lbs. (14.6 kg)	36 lbs. (16.4 kg)	36 lbs. (16.4 kg)
Maximum Power Consumption	40 watts	40 watts	48 watts
Electrical Output	2.5 MADC @ 6200 VDC	2.5 MADC @ 6200 VDC	3.2 MADC @ 6200 VDC
Classification	UL/CE	UL/CE	UL/CE
Optional Accessories	Charcoal After Filter	Charcoal After Filter	Charcoal After Filter

Application

The air cleaner is used in forced air heating, cooling and ventilating systems. It should be installed in the system such that all the system air is circulated through the air cleaner. The air cleaner will only remove the airborne contaminants delivered to it; maximum performance is obtained with the system blower set for continuous operation.

Installation Requirements

- The best location for the air cleaner is in the return air duct next to the blower compartment. In this location, the blower motor and cooling coils will be kept clean.
- **DO NOT INSTALL THE AIR CLEANER IN THE DISCHARGE AIR DUCT**
- Before installing the air cleaner, consider the application and type of HVAC system present.
- Refer to the Typical Mounting Positions section for the most common configurations.
- Refer to the Transitions section if a transition is required between the duct work and the air cleaner.
- The unit must be readily accessible for periodic inspection and cleaning of the Pre-filters and Ionizing-Collecting Cells to maintain maximum efficiency and trouble free operation.

Air Conditioning

The air cleaner should be installed upstream of the cooling coil to keep the coil clean and reduce air conditioning coil maintenance. A clean coil will reduce utility costs by maintaining the coil's efficiency. If the air cleaner is downstream of the cooling coil, condensation will form on the cooled collector plates when the air conditioner cycles. This will allow water droplets to form on the collector plates and cause nuisance arcing in the air cleaner. Arcing will reduce air cleaner efficiency and reduce the life of the high voltage power supply.

Evaporative Humidifiers

An evaporative type humidifier can be mounted either upstream or downstream of the air cleaner, depending upon the desired humidification capacity.

Atomizing Humidifiers

If an atomizing humidifier is mounted upstream of the air cleaner:

1. Mount the humidifier as far upstream in the ductwork as possible. A distance of at least 10 feet is recommended to reduce the possibility of excessive arcing as water droplets pass through the Electronic Air Cleaner.
2. Install a standard disposable furnace filter between the humidifier and the air cleaner to trap water droplets and hard water deposits.
3. Clean the air cleaner more frequently to prevent hard water buildup.

If an atomizing humidifier is mounted downstream of the air cleaner:

1. No additional considerations required.

Sheet Metal Installation

The Electronic Air Cleaner is adaptable to all new or existing residential forced air furnace and cooling systems.

Transitions

If the air duct does not fit the air cleaner cabinet opening, gradual transitions are recommended to reduce air turbulence through the air cleaner and maximize efficiency. Not more than 20° (about 4" per running foot) of expansion should be used on each side of the transition section.

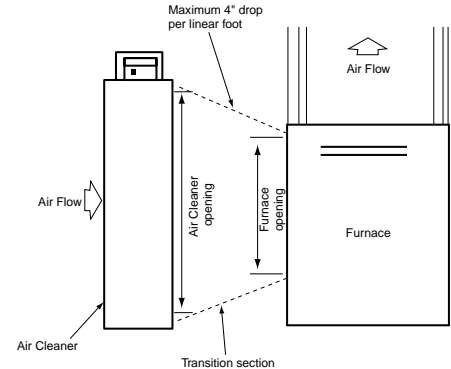

Outdoor Air

When outdoor air is added to the return air duct, sufficient heat should be added to maintain the return air temperature at 40°F (4° C) minimum. Lower temperatures can cause ionizer wire failure.

Turning Vanes

If the air cleaner is installed adjacent to a 90° duct elbow, add turning vanes inside the duct to improve air distribution across the face of the air cleaner. Failure to follow this recommendation can reduce the efficiency of the Electronic Air Cleaner.

