



## CASWELL™ 3-HOLE WIDESPREAD LAVATORY FAUCET WITH LEVER HANDLES

Modern Caswell™

**CA2202LM-2**

### FEATURES

- Solid brass construction
- Metal lever handles
- 5 15/32" spout reach
- 1/4-turn ceramic valves; self-cleaning, self-lubricating, quiet operation
- Self leveling mounting hardware
- 1.2 GPM
- 3 x 1 3/8" cutouts
- Pop-up drain, 1 1/4" pipe
- 1/2" NPT connectors

### COLORS/FINISHES

- Polished Chrome
- Polished Nickel
- Satin Nickel

### WARRANTY

- Limited Lifetime

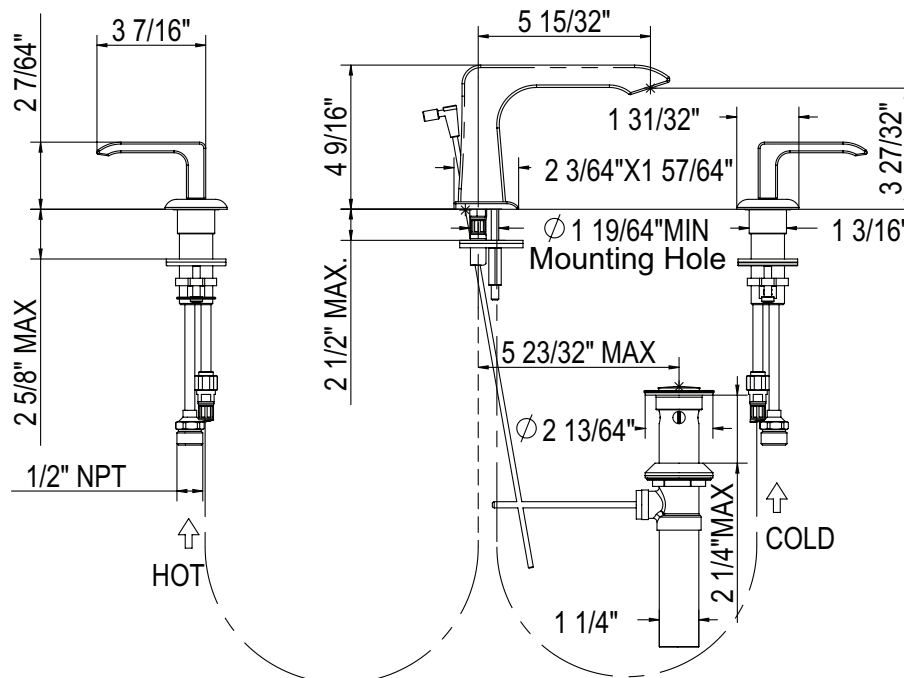

## Installation Instructions

### ROHL CASWELL DECK MOUNTED 3 HOLE LAVATORY FAUCET WITH POP UP CA2202LMPN-2, CA2202LMPN-2, CA2202LMSTN-2 INSTALLATION INSTRUCTIONS

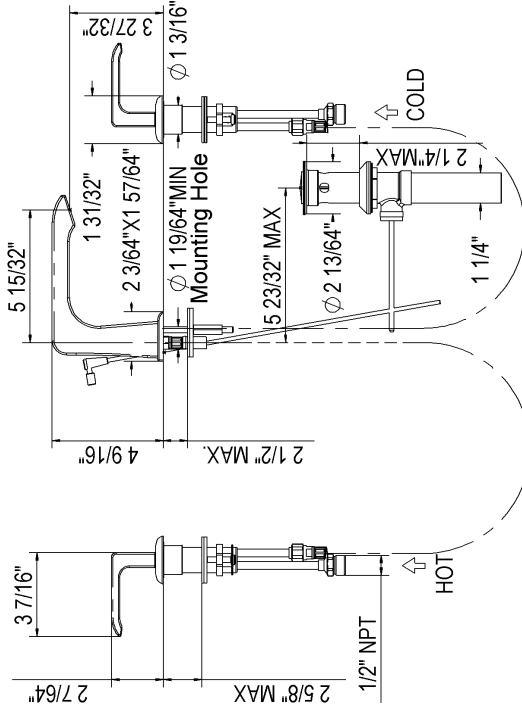

Please leave instructions with the home owner once installed.

#### SYSTEM REQUIREMENTS

To ensure the optimum performance and customer satisfaction, please adhere to the following:

- Flush out all pipe work prior to installation.
- Maximum operating pressure 75psi
- NOTE: Pressures over 75psi will require that the house have a pressure regulator installed to limit the pressure below 75psi.
- Maximum hot water temperature 145°F
- If the water temperature exceeds 145°F an approved tempering valve must be fitted.
- Maximum flow rate limited to 1.5 US gallons/minute at 60psi flow pressure.

#### Installing the Pop-up Escutcheon:

1. Remove the upper deck assembly #33 through #35 from the threaded pop-up waste body #29.
  - a. Adjust the cone washer #32, plastic friction washer #31 and mounting nut #30 and install the assembly from the below the sink.
  - b. Install the pop-up escutcheon #34 with the rubber washer #33 from above the sink.
    - i. Note: Sealing, water proof, silicone may be needed to make a seal in the sink. (Not included.)
2. Tighten the cone washer #32, plastic friction washer #31 and mounting nut #30. **Do not over tighten.**
3. Install the horizontal pop-up rod into the washer fitting.
  - a. Note: the knurled cap nut #25 has a two-piece plastic seal #26 and #27 for the horizontal pop-up rod ball fitting. Install the ball in-between the two pieces #26 and #27 and tighten. **Do not over tighten.** Over tightening may cause a stiff pop-up rod assembly.
4. Connect the horizontal pop-up rod to the decorative vertical pop-up rod (#21) using the brass Connector #23.

#### After Installation

1. Test each side valve for leaks at each connection.
2. Test the pop-up escutcheon for leaks with the water running.

#### Care and Maintenance:

After use, wipe down with a soft, dry cloth.  
For all chrome plated surfaces we recommend cleaning this product with warm soapy water and then dry with a dry soft cloth.  
Nickel plated, satin and Inca brass finishes should be cleaned with a soft cloth and warm water and then dried with a dry soft cloth.  
Do not use cream cleaners or cleaning agents containing a corrosive acid or scouring agent including, Softscrub, Comet, Ajax and Bonami, as these may damage the surface of the faucet. Do not use any spray cleaners with ammonia or alcohol like Windex, 409 or Fantastik. Any use of unsuitable cleaning agents causing damage to the surface will not be covered by the warranty.

**WARRANTY:** Warranty is limited lifetime. See ROHL website for details (www.rohlhome.com)  
A basic in-line filter system is required for the house to protect any debris from entering the water supply line to the house. (i.e. due to construction or service work on the street water main.)

## Installation Instructions

### Installation Instructions

Flush out all pipework to remove any foreign material. The hot supply should be fitted on the left when viewed from the front.

#### Installing Hot & Cold Side Valves and Trim: (2 x 1 5/16" cut-outs)

- Remove trim parts #1 through #6.
  - Remove mounting nut #12, steel washer #11 and rubber washer #10.
- Install the side valve #8 from the top of the deck.
  - Install mounting nut #12, steel washer #11 and rubber washer #10 from below the deck.
 

Do not over tighten.

    - Note: Escutcheon #6 has a pre-set height for fitting. Please set the escutcheon to the pre-set height.
    - Set escutcheon square to the sink before installing the lever assembly.
- Install the locking ring nut #5, then the plastic washer #4 and the lever #3, as shown.
  - Position the lever and escutcheon and tighten the jack screws.
- Make the connection to the supply lines to the hot and cold connections (Hoses not included.)

#### Installing the Spout: (1 5/16" cut-outs)

- Hand tighten the supply lines #17 into the spout.
 

Note: Do not over tighten. Do not crush the fitting.
- Install the **two** mounting studs #18 securely.
- Position the deck o-ring #19 on the spout and install the spout.
- Install the crescent steel washer #15 and crescent rubber washer #16. Position the spout, and tighten the **two** threaded nuts #14.
- Connect the flexi hose #17 to side valve connection #8 ensuring the #13 rubber washer is in place. **Turn the nut and not the hose.** Twisting the hose may cause damage, or low flow.

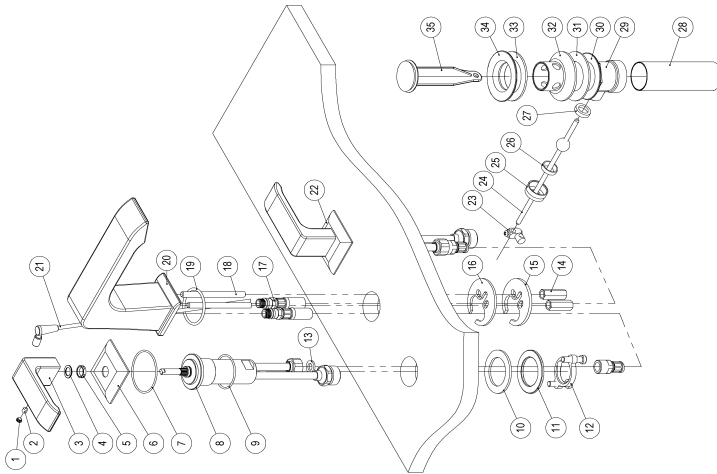

|    |                        |
|----|------------------------|
| 1  | CHROME BUTTON          |
| 2  | GRUB SCREW             |
| 3  | LEVER                  |
| 4  | PLASTIC WASHER         |
| 5  | LOCKING RING NUT       |
| 6  | ESCUTCHEON             |
| 7  | 'O' RING               |
| 8  | SIDE VALVE             |
| 9  | 'O' RING               |
| 10 | RUBBER WASHER          |
| 11 | STEEL WASHER           |
| 12 | MOUNTING NUT           |
| 13 | RUBBER WASHER          |
| 14 | THREADED NUT X 2       |
| 15 | CRESCENT STEEL WASHER  |
| 16 | CRESCENT RUBBER WASHER |
| 17 | M10-M15 HOSE           |
| 18 | MOUNTING STUDS X 2     |

|    |                             |
|----|-----------------------------|
| 19 | 'O' RING                    |
| 20 | LAVATORY DECK MOUNTED SPOUT |
| 21 | POP-UP WASTE ROD            |
| 22 | HANDLE ASSEMBLY             |
| 23 | BRASS CONNECTOR             |
| 24 | JUMPER POLE                 |
| 25 | KNURLED CAP NUT             |
| 26 | BREARING WASHER             |
| 27 | BREARING WASHER             |
| 28 | TAIL TUBE                   |
| 29 | POP-UP WASTE BODY           |
| 30 | MOUNTING NUT                |
| 31 | PLASTIC FRICTION WASHER     |
| 32 | CONE WASHER                 |
| 33 | UPPER RUBBER WASHER         |
| 34 | POP-UP ESCUTCHEON           |
| 35 | JUMPER                      |