

- 1) Pre-drill mounting holes in the locations marked on this template using a 3/32" drill bit. Be sure the template is centered left to right. The front edge of the template should be aligned with the back of the door.
- 2) Use the #8 x 3/4" Phillips head screws provided to secure the unit to the floor. The slide system can be separated if necessary to aid in installation, but removal is not required (See Fig 1 and Fig 2).
- 3) Ensure that the door mounting brackets allow the mounting screws to engage a part of the door that is at least 3/4" thick (On a 5-panel door, this would be the outer side pieces, or styles). Inset doors would move the brackets toward the center of the unit while full overlay doors would require the brackets to move outward (See Fig 3). Use the double sided tape provided to temporarily attach the door to the mounting brackets.
- 4) Carefully open the unit, being sure not to disengage the double sided tape. Once the unit is open, use the #6 x 1/2" flat head screws to permanently attach the door to the unit. All (8) screws must be used for proper function. Space screws at opposing corners as much as possible.

**Door Adjustment**

Vertical mounting slots in the bracket that attach directly to the door can be used for vertical adjustment (See Fig 4).

Horizontal adjustment is achieved by loosening all (4) of the 3/8" nuts that connect to the (2) brackets and moving the door left to right as needed (See Fig 4).

For door tilt adjustment, loosen the (4) #3 Phillips head screws below the skirt and adjust as needed. The rear screws are slotted to allow the door to pivot at the front of the bracket (See Fig 5). Keeping the front screws "snug" will aid in adjustment.

Place a flat head screw driver between the metal clip and plastic hub. Gently pry to relieve pressure by popping the clip out, taking care to keep it intact.

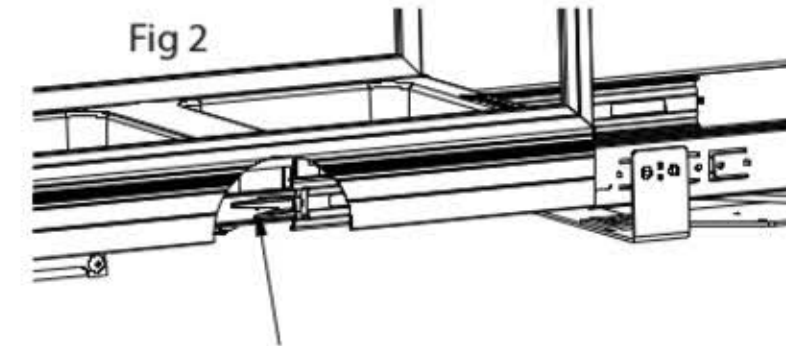
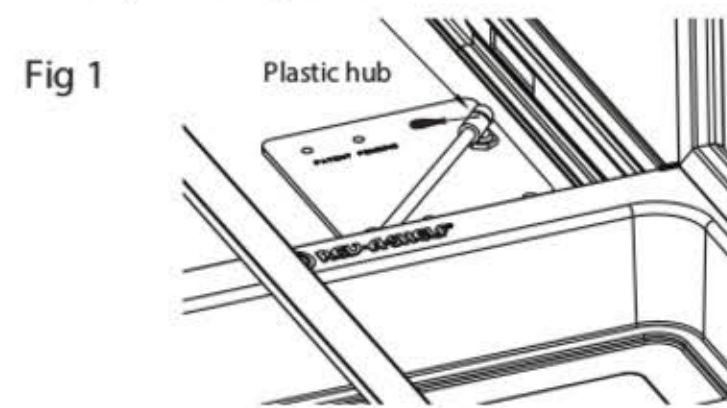

Press release lever behind side skirt on each side by sliding up or down depending on which side. Unit will separate with both levers disengaged.

Door thickness must be at least 3/4" where screws attach

Mounting screws must engage 3/4" thick material minimum.

Adjust bracket left to right before attaching door with double-sided tape.



For horizontal adjustment loosen (4) 3/8" nuts and move to desired position.

Fig 4

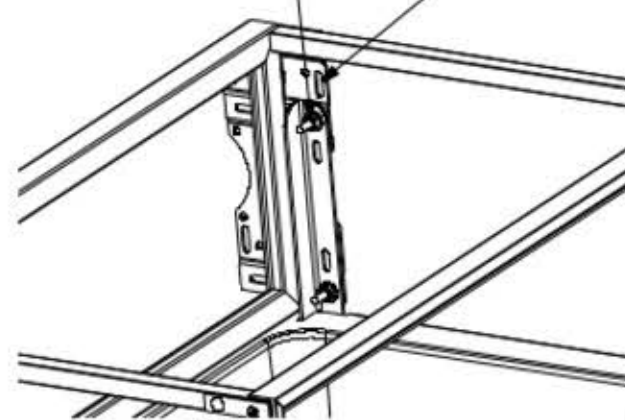

Use vertical slots for vertical door adjustment

Front of unit

Door tilt adjustment screws

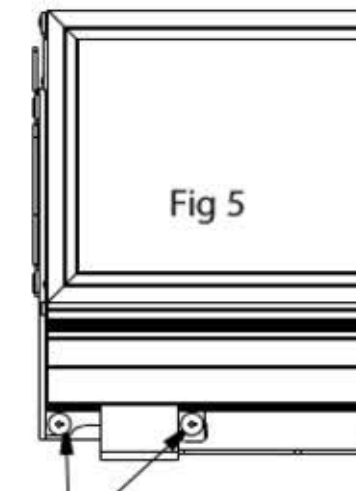

Front edge of paper to back of door.

Center of cabinet