

Soft-Close Pullout with Ball Bearing Tri-Slide

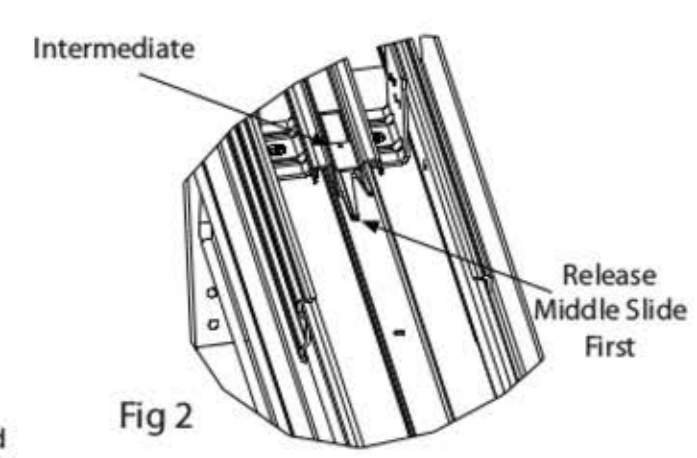

- 1) Remove cabinet member of the tri-slide from the pullout unit. It is recommended that the middle slide release be triggered first, followed by the two side slide releases. This is done by fully extending the slide (like opening the unit) and pushing the black release lever to the side. Next, slide the intermediate past the lock. Once all (3) release levers are triggered, the tri-slide unit can be removed from the pullout. (See Fig. 1 & 2).
- 2) Using the mounting template provided, pre-drill (4) holes using a 3/32" drill bit.
- 3) Attach the tri-slide cabinet member to the floor of the cabinet in the appropriate location, being sure to center the slide in the cabinet opening. Use the (4) #8 x 3/4" deep thread screws provided.
- 4) The pullout chassis can now be slid into place and fully inserted into the cabinet. Be sure that all 3 ball bearing slides are aligned properly to prevent damage to the slide. Cycle the unit fully 3-5 times to be sure that the slides are functioning as they should.
- 5) Loosen the machine screws at the top back wall of the unit to allow the rear stop to float freely. (See Fig. 3). Raise the rear stop until it catches the rear of the face frame (if frameless application, a block may need to be added to allow the stop to work properly). Once the stop is at the right height, the machine screws can be tightened. (Note: Once in place you can permanently secure the location using the pre-drilled pilot holes and the (2) #6 x 1" flat head screws provided.)

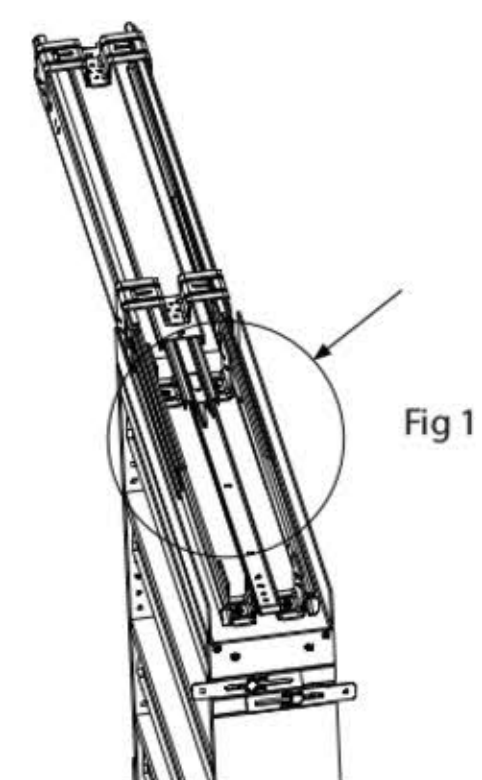
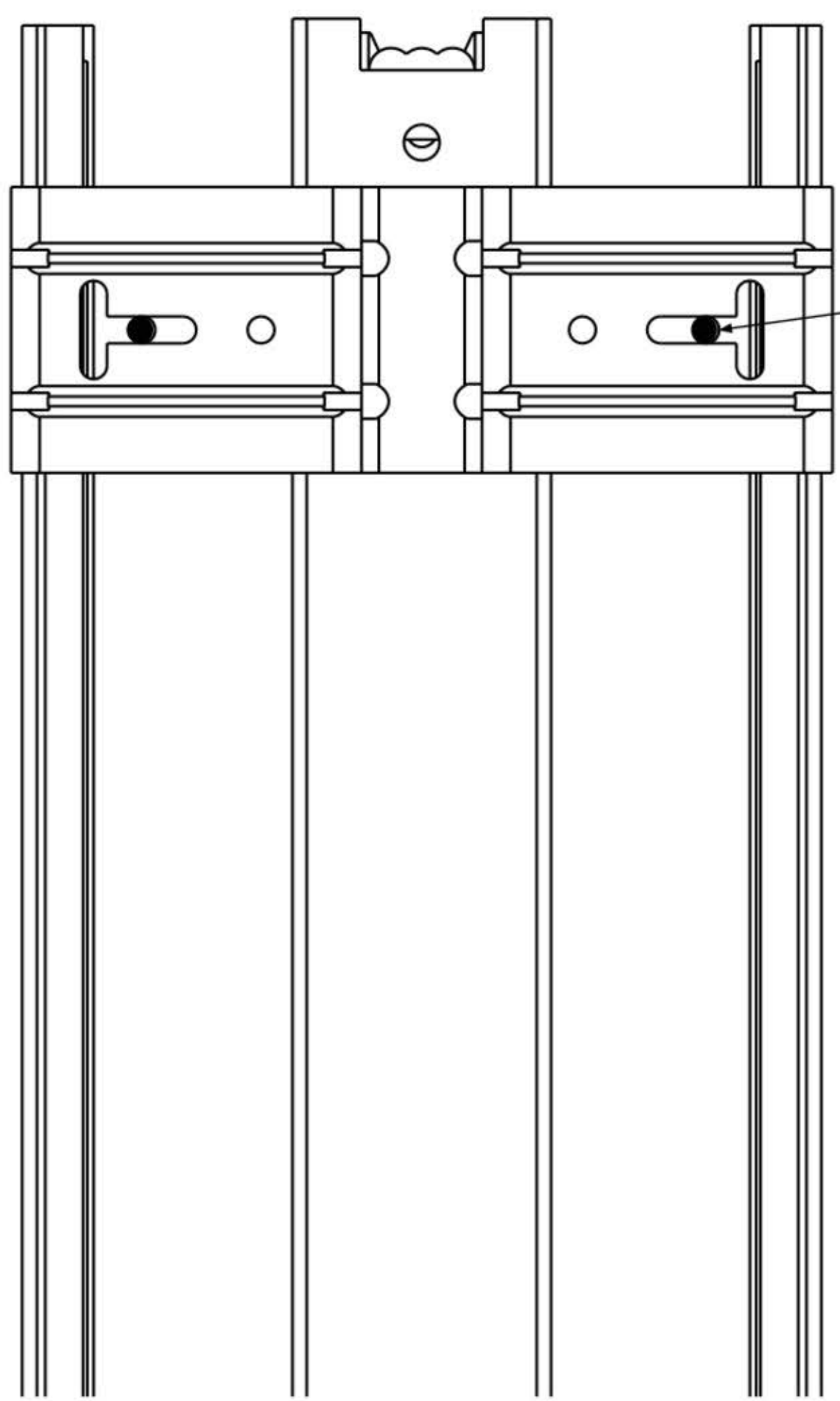
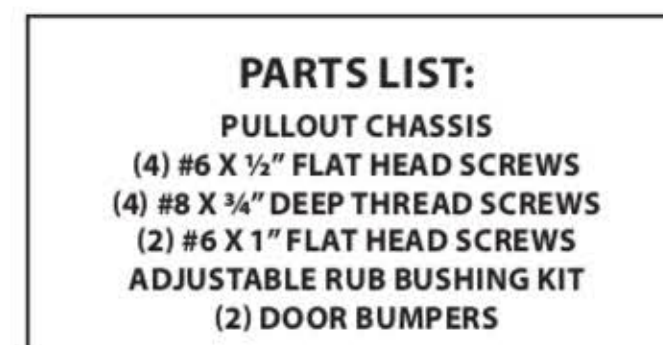
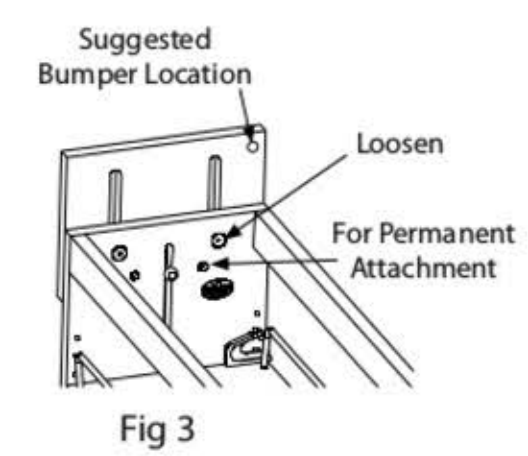

Attaching the cabinet door

- 1) Loosen the (4) lock nuts with a 3/8" wrench inside the front wall of the unit. (See Fig. 4).
- 2) Pull the Adjustable Door Mounting Brackets to ensure that you are mounting to the "thick" portion of the cabinet door. (Front of pullout should line up with the front of the face frame).
- 3) Use the (4) #6 x 1/2" flat head screws provided to attach the door to the pull out unit.
- 4) If the door needs to be tilted to lay flush against the face frame, loosen the 3/8" nuts and turn the "T-Nut" screws so that it pushes against the metal bracket. Each corner can be adjusted independently. (Note: It is recommended that door bumpers be used on each corner to ensure quiet operation.)

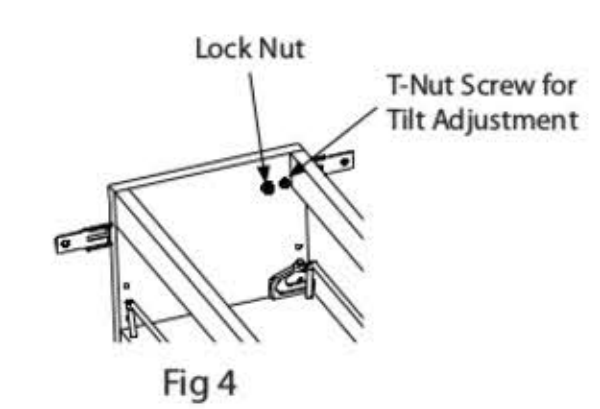

Install rub bushings using enclosed kit and instructions (Note: Chassis may need to be removed for proper installation)

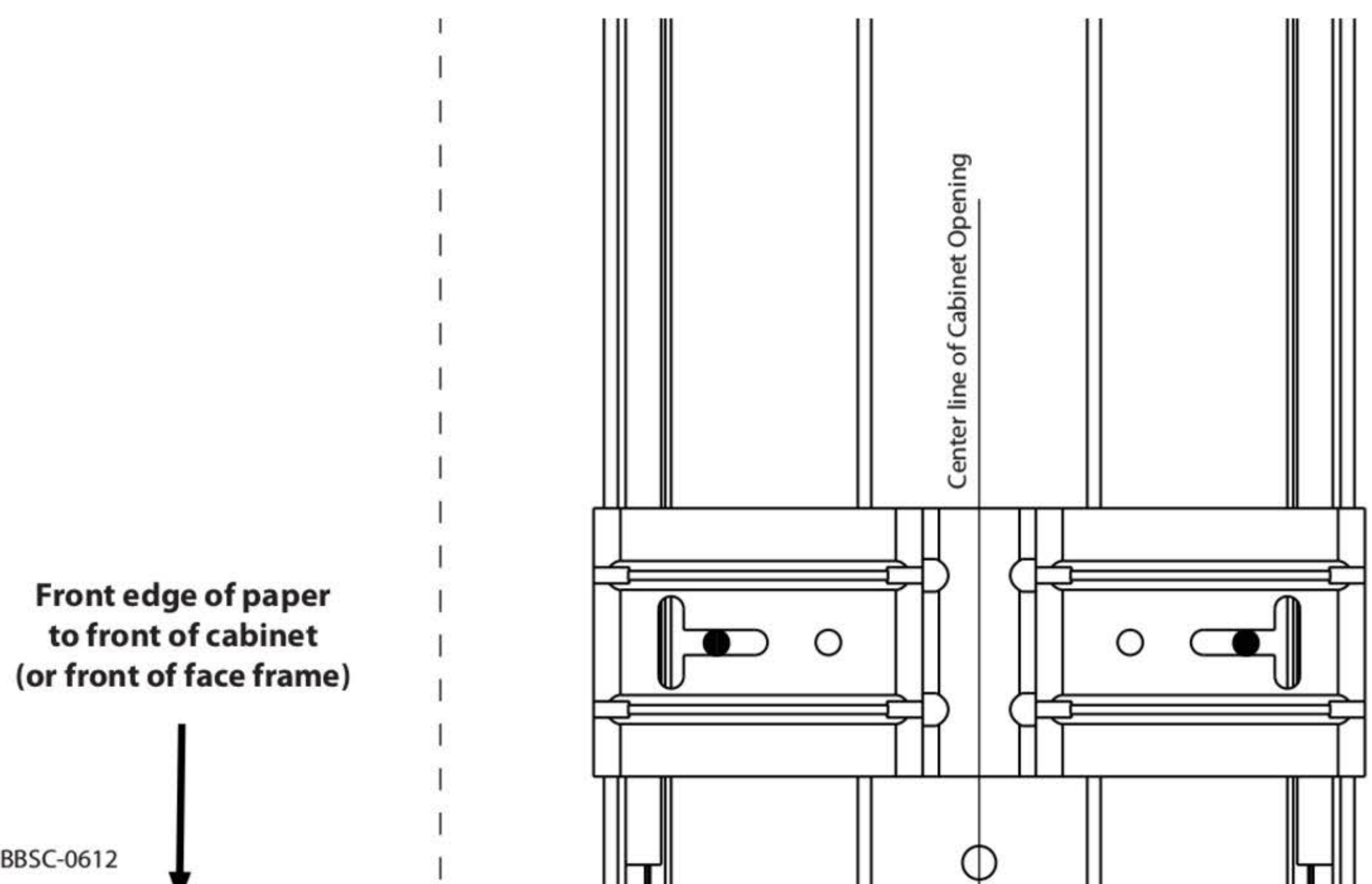

*** Use this side for 8" Wide Pullout**

*** Fold Template along this edge to fit cabinet opening.**