

Please go to [www. quozel. com](http://www. quozel. com) for product cleaning tips. Go to the **Care + Maintenance** selection.

**Tools Required:** Flathead screwdriver, Phillips screwdriver, pliers, wire cutters, wire strippers, electrical tape, safety glasses.

**Light Source:** (6)G9 Xenon Clear bulb (Supplied), 40W Maximum.

**Estimated Assembly Time:** 20-30 minutes

**Preparation:** Identify and inspect all parts before beginning installation. Check package content list and diagrams below to be sure all parts are present. If any parts are missing or damaged, do not attempt to assemble, install, or operate the fixture. Contact customer service for replacement parts.

## ⚠ Warnings and Cautions

Turn off electricity at circuit breaker or main fuse box before installation. Consult a licensed electrician if in doubt.

These instructions are provided for your safety. It is very important you read them completely before installing the fixture. We strongly recommend that a licensed, professional electrician perform the installation.

Disconnect fixture from power source before replacing bulbs. Make sure bulbs are given sufficient time to cool before removal. Do not subject glass parts to any shock while in operation or shattering may result.

Do not touch the bulb with bare hands use a cloth or glove.

## Package Contents

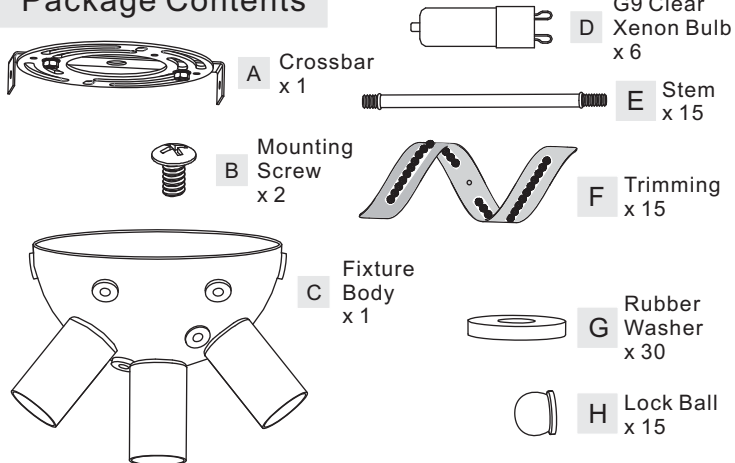

- C. Connect White Supply Wire from the Outlet Box to Wire Labeled "N" from fixture.
- D. Connect Black (or Red) Supply Wire from the Outlet Box to Wire Labeled "L" from fixture.
- E. Connect Ground Wire from the Outlet Box to Green Striped Wire from fixture.
- F. Twist connectors until wires are tightly joined together.
- G. Wrap each connection with approved electrical tape and carefully stuff all the connected wires into the Outlet Box.

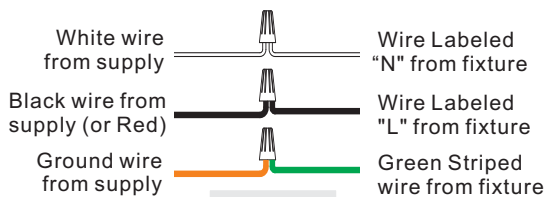
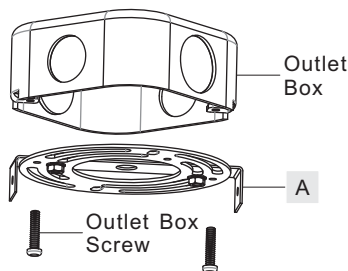

Figure 2

### STEP 1 – Attach Crossbar to Outlet Box

- A. Attach the Crossbar (A) to Outlet Box and secure by threading Outlet Box Screws (not supplied) into the Mounting Holes on the Outlet Box. Tighten until snug.

Figure 1



### STEP 3 – Attach Ceiling Canopy to Crossbar

- A. Line up the Hole on the Fixture Body (C) and the Mounting Hole on the Crossbar (A), secure by thread the Mounting Screw (B) into the Mounting Hole. Tighten until snug.

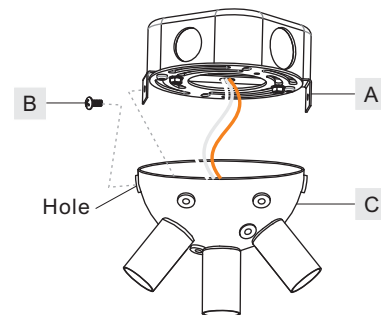

### STEP 2 – Make Wire Connections

- A. Use standard wire connectors to make all wire connections. (Connectors are not included with fixture.) Strip and prepare wire ends according to instructions supplied with connectors.
- B. If the electrical wire is going to be cut shorter than provided you will need to identify the "L" line wire and the "N" wire before you cut the excess wire off. One is labeled N and the other labeled L. The third wire has a green stripe on it. To do this strip back the clear wire covering the 3 fixture wires as far as you need to. This will expose each fixture wire individually. Separate the "L" wire from the other two and re-label the wire near where you want to make the cut. Be sure to mark the wire on the side of the fixture and not on the excess wire being cut and removed. Do the same labeling with the "N" wire.

### STEP 4 - Install Bulbs

- A. This fixture uses clear G9 Xenon bulb (D) with G9 base. Maximum 40 watts. Insert bulb and push snugly into place.

**IMPORTANT:** Do not touch the bulb with bare hands use a cloth or glove.

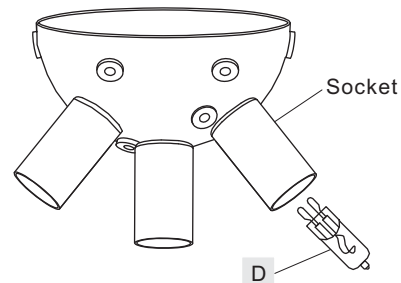

**Thank you for purchasing a Quozel product.**  
**Need assistance with parts or assembly? Call Quozel customer service at 1-631-273-2700**  
**or visit us on-line at [www. quozel. com](http://www. quozel. com)**

**STEP 6 – Install Trimming to Fixture**

- A. Thread the Short Nipple end of Stem (E) into the Fixture Body (C), hand tighten until snug.
- B. Peel off Protective Films on Trimmings (F).  
Note: Gloves are required to avoid leaving fingerprints or scratches on Trimmings (F).
- C. Place the Trimming (F) and Rubber Washer (G) over the other end of Stem (E). Secure by threading Lock Ball (H) onto the Stem (E). Hand tighten until snug.

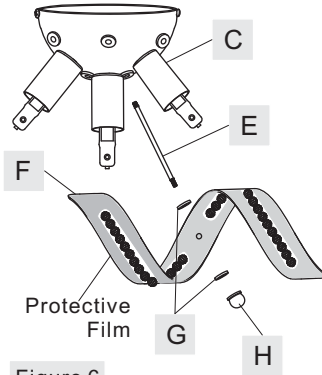

Figure 6

**CAUTION FOR BULB REPLACING**

- A. When replace bulb, turn off power and allow lamp to cool. For safety purpose, wear gloves and eye protection.
- B. If bulb is scratched or cracked, DO NOT use the lamp to avoid breakage during use or installation.
- C. Use only in fixtures rated for lamps wattage and voltage.
- D. Prevent the bulb from contacting liquid or combustible materials.

Your fixture is now assembled and ready to use. Enjoy!

RBN1628CRC

FINISH: CRYSTAL CHROME

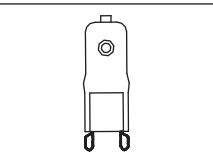
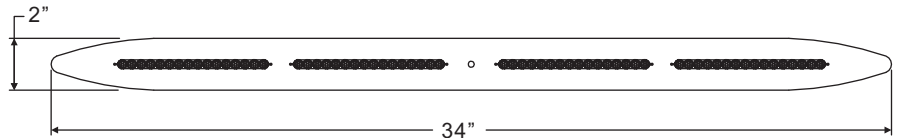
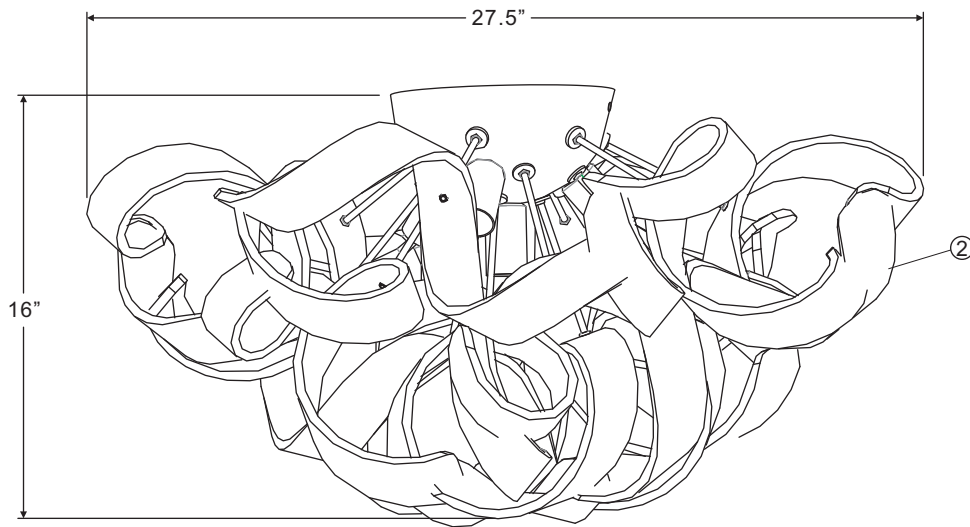
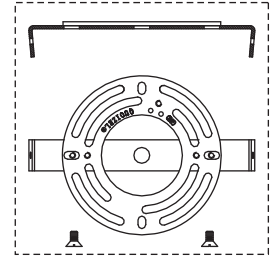

(6) 40W Maximum G9 Xenon Clear Bulbs (Supplied)

①

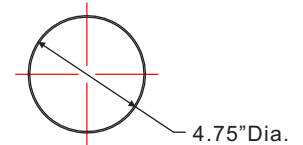
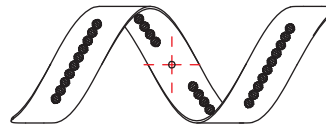

NOTE: ALL DIMENSIONS ARE ROUNDED UP TO THE NEAREST 1/4"

| NO. | PART NUMBER | REPLACEMENT PART DESCRIPTION | REQ. |
|-----|-------------|------------------------------|------|
| 1   | I1202SC     | XENON G9 CLEAR BULB          | 6    |
| 2   | S12020CRC   | SHADE RIBBON CRYSTAL CHROME  | 15   |

Thank you for purchasing a Quoizel product.  
Need assistance with parts or assembly? Call Quoizel customer service at 1-631-273-2700  
or visit us on-line at [www.quoizel.com](http://www.quoizel.com)