

Please go to [www.quoizel.com](http://www.quoizel.com) for product cleaning tips. Go to the **Care + Maintenance** selection.

**Tools Required:** Flathead screwdriver, Phillips screwdriver, pliers, wire cutters, wire strippers, electrical tape, safety glasses.

**Light Source:** (3) G9 Xenon Frosted bulb (Supplied), 50W Maximum.

**Estimated Assembly Time:** 20-30 minutes

**Preparation:** Identify and inspect all parts before beginning installation. Check package content list and diagrams below to be sure all parts are present. If any parts are missing or damaged, do not attempt to assemble, install, or operate the fixture. Contact customer service for replacement parts.

## ⚠ Warnings and Cautions

Turn off electricity at circuit breaker or main fuse box before installation. Consult a licensed electrician if in doubt.

These instructions are provided for your safety. It is very important you read them completely before installing the fixture. We strongly recommend that a licensed, professional electrician perform the installation.

Disconnect fixture from power source before replacing bulbs. Make sure bulbs are given sufficient time to cool before removal. Do not subject glass parts to any shock while in operation or shattering may result.

Do not touch the bulb with bare hands use a cloth or glove.

## Package Contents

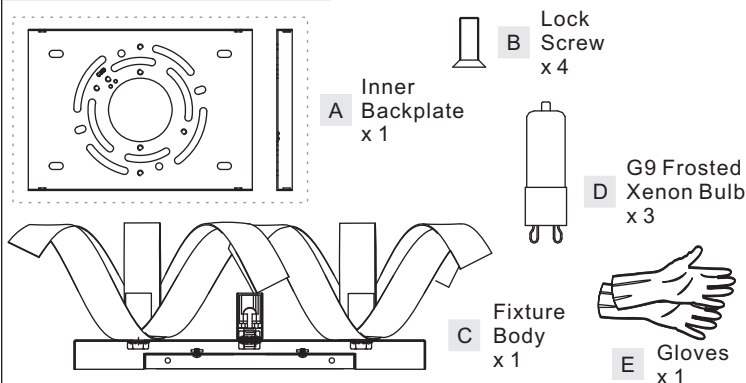

### STEP 1 - Install Inner Backplate and Fixture Body

- Pass the supply wires through Inner Backplate (A). Attach Inner Backplate (A) to Outlet Box with the head of Green Ground Screw facing you. Secure it with Outlet Box Screws (not included). Tighten until snug.
- Race all supply wires through the Inner Backplate (A) as shown. Refer to Step 2 for wiring connections.
- Attach Fixture Body (C) over Inner Backplate (A) and secure with Lock Screws (B). Tighten until snug with screwdrivers.

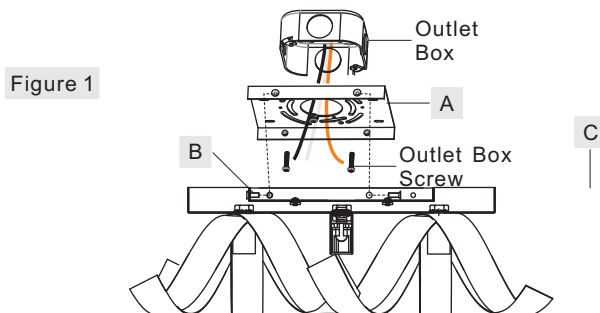

### STEP 2 - Wire Connections

- Use standard wire connectors (not included) to make all wire connections. (Connectors are not included with fixture.) Twist connectors until wires are tightly joined together. Wrap each connection with approved electrical tape and carefully stuff all the connected wires between Inner Backplate (A) and Fixture Body (D).

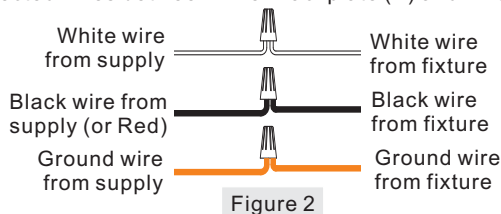

### STEP 3 - Install Bulbs

- Wear the Gloves (E), push Aluminum Sheet for more room to install Bulbs.
- This fixture uses frosted G9 Xenon bulb (D) with G9 base. Maximum 50 watts. Insert bulb and push snugly into place.

**IMPORTANT:** Do not touch the bulb with bare hands use a cloth or glove.

Your fixture is now assembled and ready to use. Enjoy!

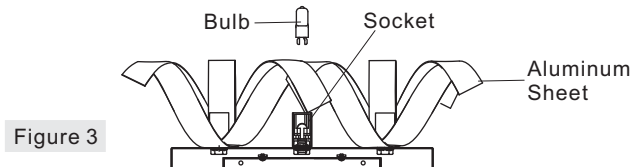

### CAUTION FOR BULB REPLACING

- When replace bulb, turn off power and allow lamp to cool. For safety purpose, wear gloves and eye protection.
- If bulb is scratched or cracked, DO NOT use the lamp to avoid breakage during use or installation.
- Use only in fixtures rated for lamps wattage and voltage.
- Prevent the bulb from contacting liquid or combustible materials.

**Thank you for purchasing a Quoizel product.**  
Need assistance with parts or assembly? Call Quoizel customer service at 1-631-273-2700  
or visit us on-line at [www.quoizel.com](http://www.quoizel.com)

RBN8603MN

FINISH: MILLENIA

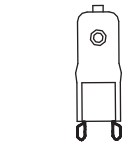
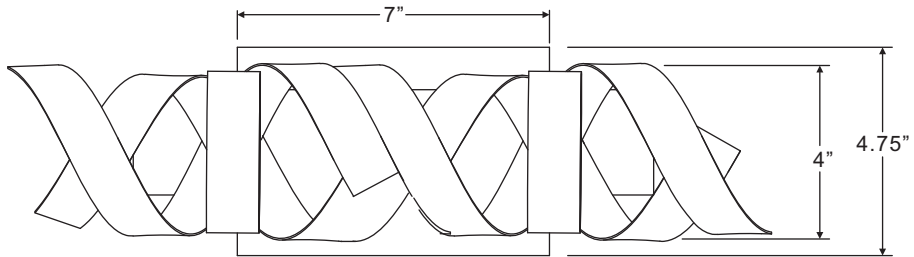
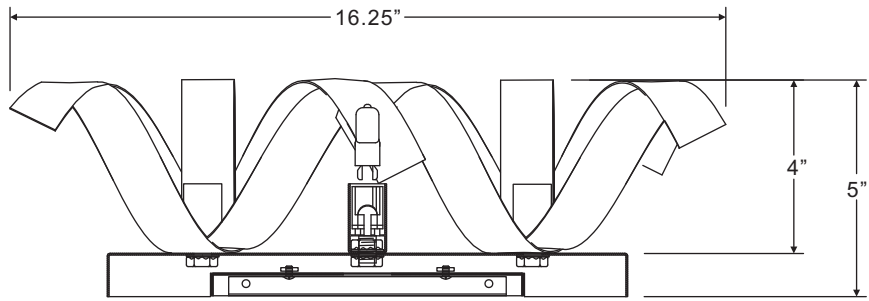
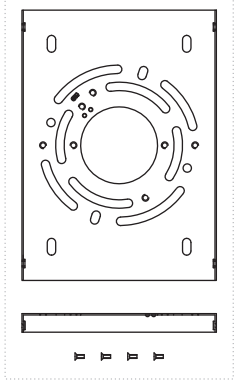

(3) 50W Maximum  
G9 Xenon Frosted  
Bulbs (Supplied)

NOTE: ALL DIMENSIONS ARE ROUNDED UP TO THE NEAREST 1/4"

NO.	PART NUMBER	REPLACEMENT PART DESCRIPTION	REQ.
1			

Thank you for purchasing a Quoizel product.  
Need assistance with parts or assembly? Call Quoizel customer service at 1-631-273-2700  
or visit us on-line at [www.quoizel.com](http://www.quoizel.com)