



Compact Fluorescent

**Promenade**  
Energy Star<sup>®</sup> Qualified

**Outdoor**

Type \_\_\_\_\_  
-31WB

P6518

Catalog No.	Finish	Lamping	Dimensions (Inches)		
	Black		A	B	C
P6518	-31WB	1-26w GU-24 (included)	8-1/2	14-3/8	89

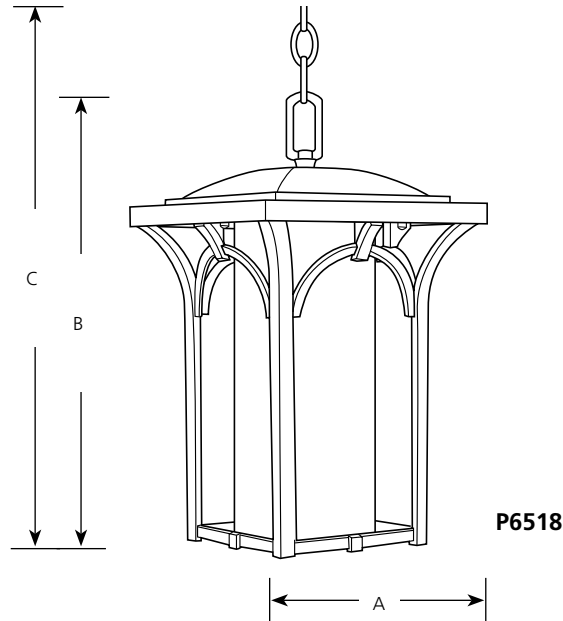

**Specifications:**

General

- Etched opal glass cylindrical diffuser: 4-3/4" dia., 10-9/16" ht.
- Painted Black (-31WB) finish
- Cast aluminum construction
- Six feet of 9 gauge chain supplied.
- GU24 base lamp (included)
- Energy Star<sup>®</sup> qualified
- Companion Post top lantern, Wall lantern, fixtures are available

Mounting

- Ceiling chain mount
- Canopy covers a standard 4" hexagonal recessed outlet box
- Mounting strap for outlet box included

Electrical

- GU24 base socket
- Pre-wired

Labeling

- cCSAus Damp location listed



Progress Lighting  
701 Millennium Blvd.  
Greenville, South Carolina  
29607

www.progresslighting.com

Rev. 10/13