

	Type		
	-09STR	-19STR	-31STR
P5985	<input type="checkbox"/>	<input type="checkbox"/>	<input type="checkbox"/>
P5986	<input type="checkbox"/>	<input type="checkbox"/>	<input type="checkbox"/>

Catalog No.	Finish			Lamping	Dimensions (Inches)			
	Brushed Nickel	Roman Bronze	Black		A	B	C	D
P5985	-09STR	-19STR	-31STR	1 26w GU24 CF*	4-5/8	10	6-1/8	2-3/4
P5986	-09STR	-19STR	-31STR	1 13w GU24 CF*	4-5/8	8-1/2	6-1/8	2-3/4

*Spiral

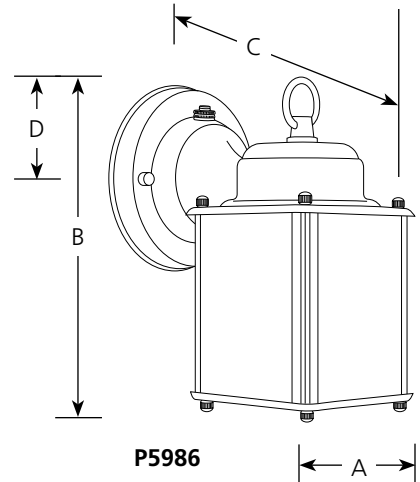
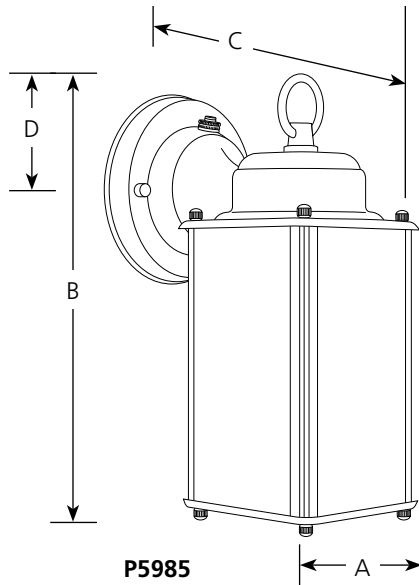

Specifications:

General

- Square style
- Solid brass construction
- Plated brushed nickel (-09) and roman bronze (-19); painted black (-31)
- Etched white glass panels
- Lamp replacement through bottom opening

Mounting

- Wall mounted outdoor.
- Covers standard recessed octagonal outlet box
- Mounting strap for outlet box and cap nuts included

Electrical

- GU24 base socket
- Integral photocell turns unit off during daytime
- Unit will start down to 0 degrees F
- Pre-wired

Labeling

- cCSAus "Wet Location" listed