



Compact Fluorescent

Roman Coach

Outdoor

Catalog No.	Finish			Lamping	Dimensions (Inches)			
	Brushed Nickel	Antique Bronze	Textured Black		A	B	C	D
P5772	-09	-20	-31	1-26w GU-24	7	19-5/8	6-7/8	16-1/4

Type	-09	-20	-31
P5772	<input type="checkbox"/>	<input type="checkbox"/>	<input type="checkbox"/>

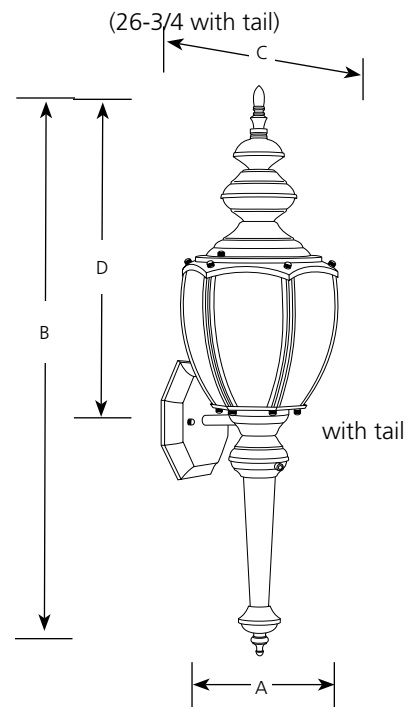
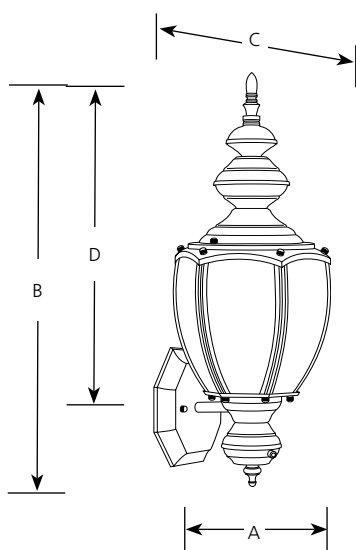

Specifications:

General

- Etched Seeded glass curved panels
- Acorn style
- Aluminum construction
- Plated Brushed Nickel (-09) finish
- Painted Antique Bronze (-20), Textured Black (-31) finishes
- Decorative tail supplied with unit. Can be installed with or without tail
- Lamp replacement, remove top of unit
- Companion Post top lantern, Wall lantern, fixtures are available

Mounting

- Wall mount
- Back plate covers a standard 4" hexagonal recessed outlet box
- Mounting strap for outlet box included

Electrical

- GU24 base socket
- Pre-wired

Labeling

- cCSAus Wet location listed

Progress Lighting
 701 Millennium Blvd.
 Greenville, South Carolina
 29607

www.progresslighting.com

Rev. 08/13