



Incandescent

Torque

Bath & Vanity

Type \_\_\_\_\_  
-09WB -124WB

P2719	<input type="checkbox"/>	<input type="checkbox"/>
P2720	<input type="checkbox"/>	<input type="checkbox"/>
P2721	<input type="checkbox"/>	<input type="checkbox"/>
P2722	<input type="checkbox"/>	<input type="checkbox"/>

Catalog No.	Finish		Lamping	Dimensions (Inches)			
	Brushed Nickel	Copper Bronze		A	B	C	D
P2719	-09WB	-124WB	1 Halogen (G9, 120V) 60w (included)	5-7/8	5	7-5/8	2-1/2
P2720	-09WB	-124WB	2 Halogen (G9, 120V) 60w (included)	14-1/2	5	7-5/8	2-1/2
P2721	-09WB	-124WB	3 Halogen (G9, 120V) 60w (included)	23	5	7-5/8	2-1/2
P2722	-09WB	-124WB	4 Halogen (G9, 120V) 60w (included)	31-1/2	5	7-7/8	2-1/2

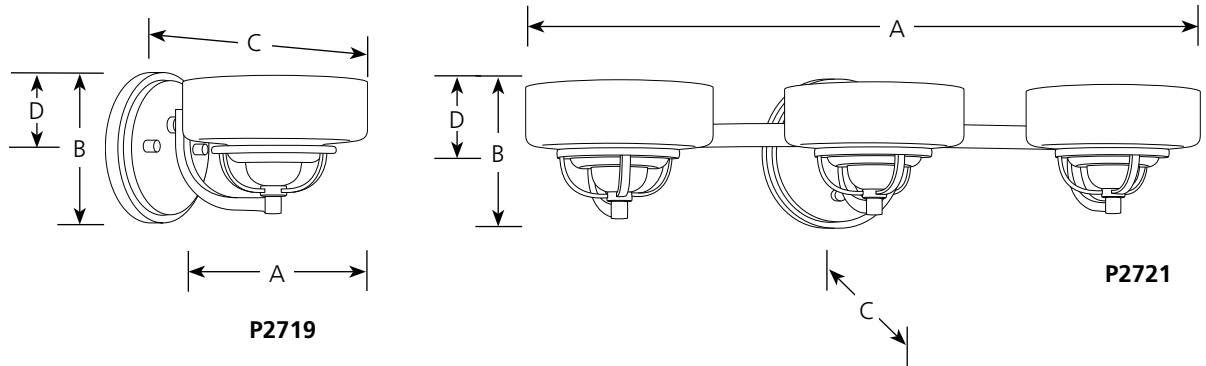

**Specifications:**

General

- Opal etched mouth-blown glass shade: 5-7/8" dia.
- Plated Brushed Nickel (-09WB), Copper Bronze (-124WB) finishes
- Steel construction
- 60w Halogen (G9, 120V) lamps (included)
- Companion Bath and Vanity, Chandelier, Close-to-ceiling, Pendant, fixtures are available

Mounting

- Wall mount
- Back plate covers a standard 4" hexagonal recessed outlet box: 5" dia.
- Mounting strap for outlet box included
- Mounts in "up" or "down" position

Electrical

- Looped bipin base porcelain socket(s)
- Pre-wired

Labeling

- cCSAus Damp location listed

Progress Lighting  
701 Millennium Blvd.  
Greenville, South Carolina  
29607

www.progresslighting.com

Rev. 05/13