



Compact  
Fluorescent Trim

**6"Pro-Optic™ Lensed**  
**1 Horizontal Lamp**  
Non-IC

Recessed

Type \_\_\_\_\_  
-68      -83  
P8016       

**Finish**

Catalog No.	Finish	
	Prismatic	Fresnel
P8016	-68	-83

**Dimensions (Inches)**

A	B	C
7	6-3/16	4-1/2

Maximum Ceiling Thickness: 1-1/8"

Ceiling Opening: 6-1/4" (see guide for retrofit)

P162H HOUSING COMPATIBILITY GUIDE		
ORDERING GUIDELINES	6 INCH OPENING RANGE	
	MIN	MAX
REQUIRES SD HOUSING OPTION	5-15/16	6-1/8
ALL STANDARD HOUSINGS	6-1/8	6-1/2
ONLY P8030 SERIES TRIMS AVAILABLE: 'WF' OPTION	6-1/2	6-7/8

Dimensions shown are for the diameter of the frame flange at its narrowest point

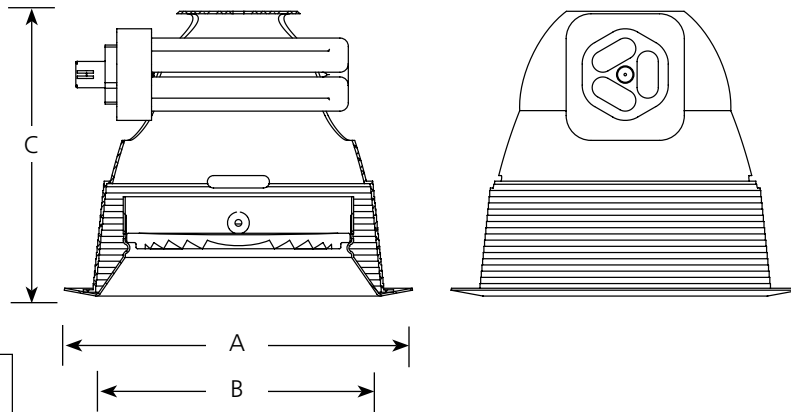
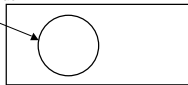

**Lamp Wattage**

**Housing**

**New Construction**  
P6132-EB

**Retrofit**  
P162H-EB

**IC**  
N/A

**Non-IC**  
1-26 or 32w Triple Tube

**Specifications:**

Trim

- White painted regressed metal trim with integral flange retains the lenses
- Attaches to reflector with two scissor springs

Reflector

- All aluminum construction
- One piece construction with integral flange
- No light leaks around trim flange
- Socket cup mounts to reflector for optimum performance and consistent lamp position
- Reflector retention accomplished by spring clips located in aperture of housing
- White painted finish

Lens

- Fresnel (-83) or Prismatic (-68) glass lenses
- Protects lamps from below ceiling

Labeling

- cCSAus listed for wet locations
- Non-IC rated

Progress Lighting  
701 Millennium Blvd.  
Greenville, South Carolina  
29607

