



Incandescent

Jack

Outdoor

Type _____
-20

P5948

P5949

Finish

Catalog No.	Finish		Lamping	Dimensions (Inches)			
	Antique Bronze			A	B	C	D
P5948	-20		1 (m) 100w	6-1/8	13-3/4	6-3/8	5-1/8
P5949	-20		1 (m) 100w	8-1/8	15-3/8	6-3/8	5-7/8

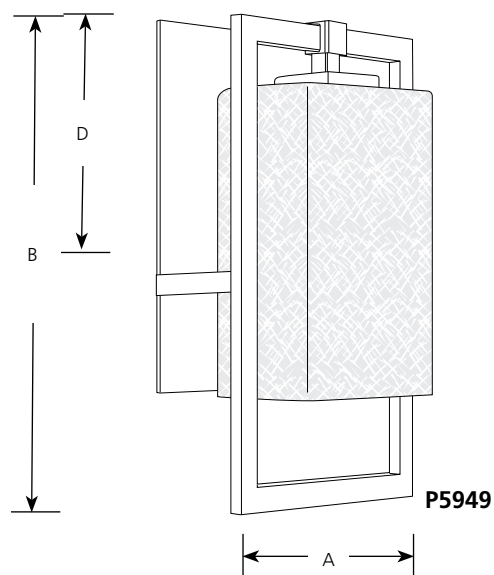
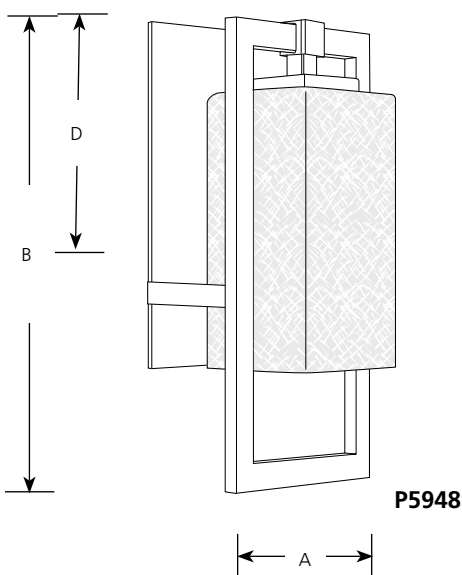
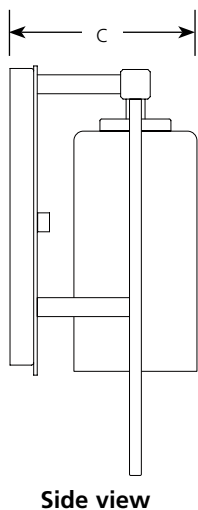

Specifications:

General

- Etched amber flax glass shade
P5948: 4-1/8" sq., 8" ht.
P5949: 6" W., 3-15/16" depth, 9-7/16" ht.
- Steel construction
- Painted Antique Bronze (-20) finish

Electrical

- Medium base porcelain socket
- Pre-wired

Labeling

- cCSAus Wet location listed

Mounting

- Wall vertical mount
- Back plate covers a standard 4" hexagonal recessed outlet box
P5948: 4-9/16" W., 9-11/16" ht.
P5949: 6-9/16" W., 11-1/4" ht.
- Mounting strap for outlet box included

Progress Lighting
701 Millennium Blvd.
Greenville, South Carolina
29607

www.progresslighting.com

Rev. 09/13