



Incandescent

**Roman Coach**

**Outdoor**

Energy Star

Type \_\_\_\_\_  
 -19EB -31EB -33EB  
 P5766

| Catalog No. | Finish       |       |              | Lamping                                 | Dimensions (Inches) |       |   |       |
|-------------|--------------|-------|--------------|---|---------------------|-------|---|-------|
|             | Roman Bronze | Black | Cobble stone |   | A                   | B     | C | D     |
| P5766       | -19EB        | -31EB | -33EB        | 1-13w 4 pin CF<br>Spiral or triple tube | 6                   | 9-7/8 | 7 | 3-1/2 |

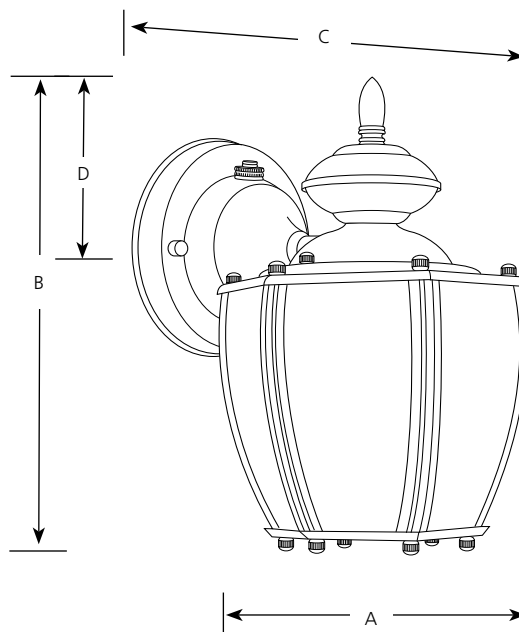

**Specifications:**

General

- Acorn style
- Solid brass construction
- Plated bronze (-19), painted black (-31), or cobblestone (-33) finishes
- Etched white glass panels
- Lamp replacement through bottom opening
- Energy Star certified
- Matching wall units

Mounting

- Wall mounted outdoor.
- Covers standard recessed octagonal outlet box
- Mounting strap for outlet box and cap nuts included

Electrical

- GX24q-1 based socket
- 120v NPF electronic ballast
- Integral photocell turns unit off during daytime
- Unit will start down to 0 degrees F
- Pre-wired

Labeling

- UL-CUL wet location listed



Progress Lighting  
 701 Millennium Blvd.  
 Greenville, South Carolina  
 29607

www.progresslighting.com

Rev. 11/07