



Compact Fluorescent

Roman Coach

Outdoor

Energy Star

	Type			
	-09EB	-19EB	-31EB	-33EB
P5770	<input type="checkbox"/>	<input type="checkbox"/>	<input type="checkbox"/>	<input type="checkbox"/>

Catalog No.	Finish				Lamping	Dimensions (Inches)			
	Brushed Nickel	Roman Bronze	Cobble Black	Cobble Stone		A	B	C	D
P5770	-09EB	-19EB	-31EB	-33EB	1-26w 4 pin CF* 7	15-3/8	7-1/4	6-7/8	

*Spiral or triple tube

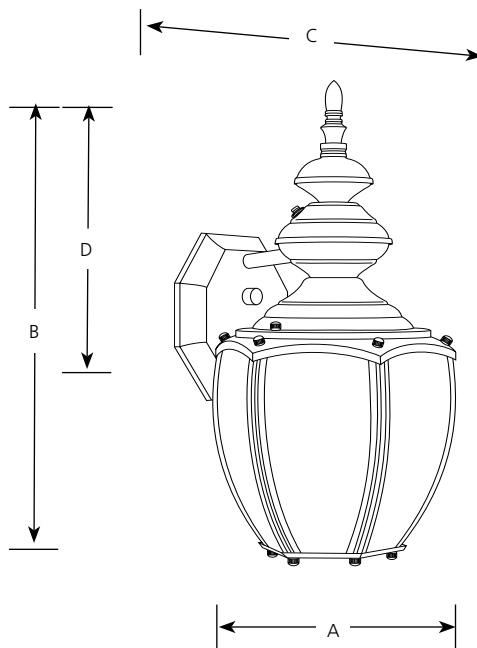

Specifications:

General

- Acorn style
- Solid brass construction
- Plated nickel (-09), or bronze (-19), painted black (-31), or cobblestone (-33) finishes
- Etched white glass curved panels
- Lamp replacement through bottom opening
- Energy Star certified
- Matching wall units

- Mounting strap for outlet box included

Electrical

- GX24q-3 socket
- 120v NPF electronic ballast
- Integral photocell turns unit off during daytime
- Unit will start down to 0 degrees F
- Pre-wired

Labeling

- UL-CUL wet location listed

Mounting

- Wall mounted outdoor.
- Covers standard 4" recessed octagonal outlet box



Progress Lighting
701 Millennium Blvd.
Greenville, South Carolina
29607

www.progresslighting.com

Rev. 4/08