

Type _____

-09 -74

P2745

Finish

| Catalog No. | Finish | | Lamping | Dimensions (Inches) | | | |
|-------------|----------------|-----------------|------------|---------------------|---|-------|-------|
| | Brushed Nickel | Venetian Bronze | | A | B | C | D |
| P2745 | -09 | -74 | 4 (m) 100w | 32-1/8 | 9 | 7-1/8 | 2-1/8 |

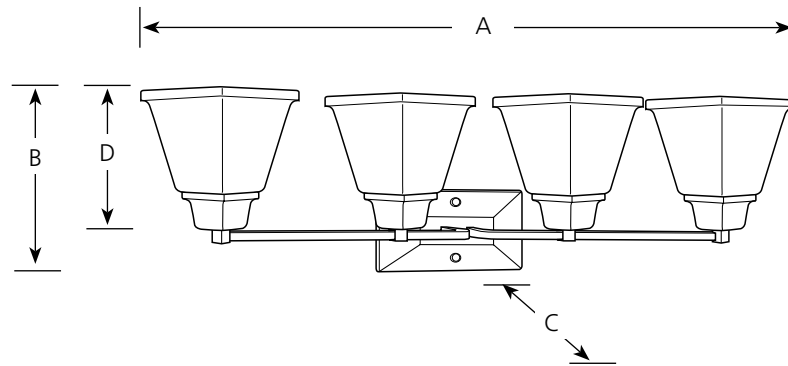

Specifications:

General

- Square etched glass shade: 5-1/2" dia. x 5" ht., 1-5/8" center hole
- Square bar supports the shades
- Plated Brushed Nickel (-09) or painted Venetian Bronze (-74) finish
- Can be mounted in "up" or "down" position
- Steel construction
- Companion foyer, chandelier, pendant, close to ceiling, and bath and vanity units

Mounting

- Wall mounted
- Unit covers a standard 4" recessed octagonal outlet box
- Backplate is 4-1/4" W x 8" T x 1" deep
- Mounting strap for outlet box included

Electrical

- Medium based ceramic socket
- Pre-wired

Labeling

- UL-CUL listed