

Type _____
 -09 -20 -33
 P4282

Catalog No.	Finish			Lamping	Dimensions (Inches)		
	Brushed Nickel	Antique Bronze	Cobble-stone		A	B	C
P4282	-09	-20	-33	3 (m) 100w	32	24	98-1/4

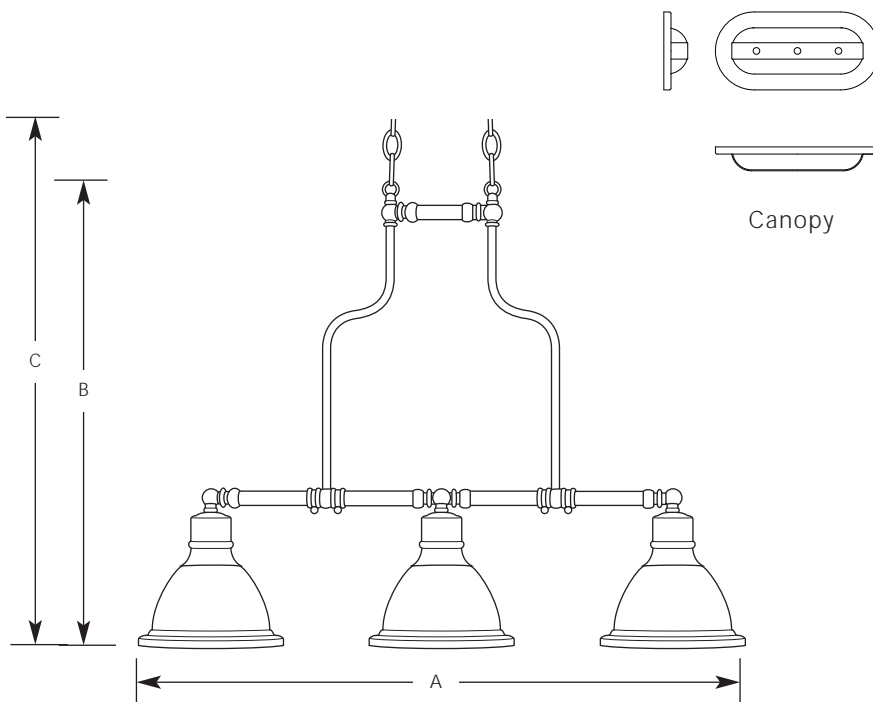

Specifications:

General

- Etched glass shades, 7-1/2" dia., 4-3/8" tall
- Concealed glass shade retention
- Chandelier arms can be rotated to an "up" or "down" position
- Steel construction
- 6ft of 9ga. chain
- Plated brushed nickel. The others are hand painted
- Companion bath, hall & foyer, pendant, and close to ceiling units

Mounting

- Ceiling mounted
- Canopy covers a standard recessed 4" octagonal outlet box
- Canopy 10" w, 1-7/16" ht., 4-3/4" depth
- Mounting strap for outlet box included

Electrical

- Ceramic medium based sockets
- Pre-wired

Labeling

- UL-CUL listed