



Compact Fluorescent

Andover

Outdoor

Type _____

-20

P5888

Catalog No.	Finish	Lamping	Dimensions (Inches)			
	Antique Bronze		A	B	C	D
P5888	-20	1-26w GU-24	7-1/2	21-3/8	8-1/4	7-1/2

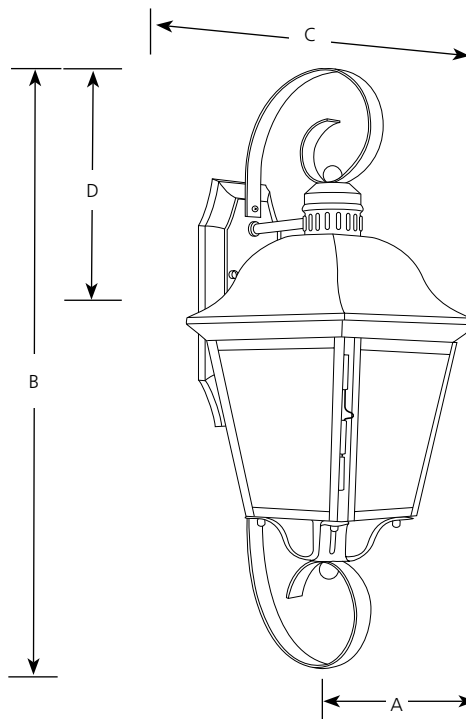

Specifications:

General

- Etched glass panels
- Painted Antique Bronze (-20) finish
- Aluminum construction
- Scroll decorative elements
- Has a hinged door for re-lamping
- Companion Chain hung lantern, Post top lantern, Wall lantern fixtures are available

Mounting

- Wall mount
- Back plate covers a standard 4" hexagonal recessed outlet box
- Mounting strap for outlet box included

Electrical

- GU24 base socket
- 6" of wire supplied
- Pre-wired

Labeling

- UL-CUL Wet location listed

Progress Lighting
 701 Millennium Blvd.
 Greenville, South Carolina
 29607

www.progresslighting.com

Rev. 09/14