



Compact Fluorescent

Andover

Outdoor

Type _____
-20

P5887

Catalog No.	Finish		Lamping	Dimensions (Inches)			
	Antique Bronze			A	B	C	D
P5887	-20		1 GU-24 13w	5-1/2	12-5/8	6-1/4	6-5/16

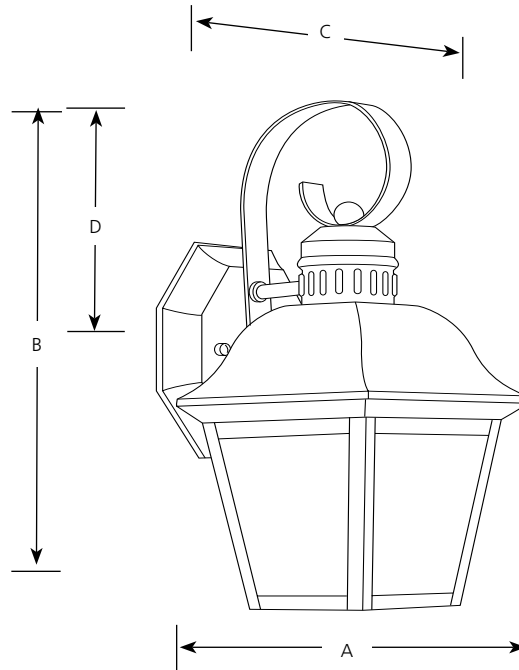

Specifications:

General

- Etched glass panels
- Painted Antique Bronze (-20) finish
- Scroll decorative elements
- Aluminum construction
- Relamps from below
- Painted finish

Electrical

- GU24 base socket
- Pre-wired

Labeling

- UL-CUL wet location listed

Mounting

- Wall mount outdoor
- Covers a standard 4" recessed octagonal recessed outlet box
- Mounting strap included

Progress Lighting
701 Millennium Blvd.
Greenville, South Carolina
29607

www.progresslighting.com

Rev. 09/14