



Compact Fluorescent

Non-Metallic
Energy Star

Outdoor

Type _____
-30EB -31EB
P5748

Catalog No.	Finish		Lamping	Dimensions (Inches)			
	White	Black		A	B	C	D
P5748	-30EB	-31EB	1-4 pin 18w Quad CFL	8	19-7/8	8-1/4	10

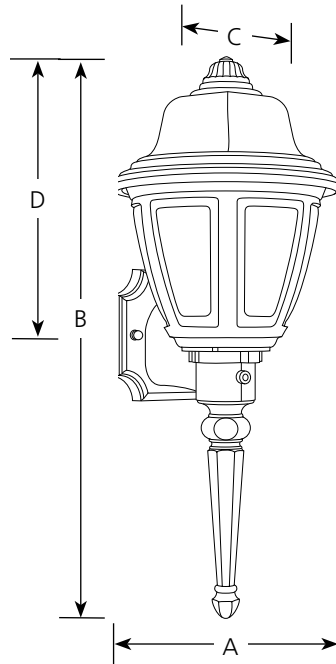

Specifications:

General

- Curved white acrylic panels
- Captive top of unit hinges for lamp replacement
- Polypropylene construction
- White (-30) or black (-31) material
- Energy Star certified

- Unit will start down to 0 degrees F
- Integral photocell turns unit off during daytime
- Pre-wired

Labeling

- UL-CUL wet Location listed

Mounting

- Wall mount outdoor
- Covers a standard 4" recessed octagonal recessed outlet box
- Mounting strap included

Electrical

- Unit has a 4 pin GX24q-2 socket.
- 120v NPF electronic ballast