

Type _____
 -09 -20
 P4326

Catalog No.	Finish		Lamping	Dimensions (Inches)		
	Brushed Nickel	Antique Bronze		A	B	C
P4326	-09	-20	4 (m) 100w	19	20-1/2	95

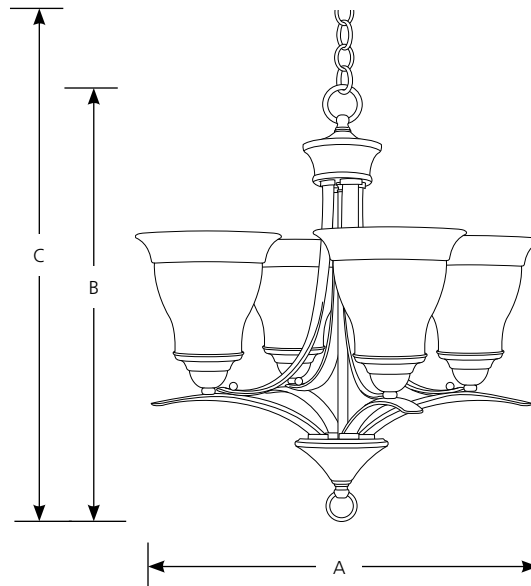

Specifications:

General

- Etched glass shades with slight banding: 6-1/2" dia.
- Uplight style four light chandelier
- Oval tubing with pinched ends
- Brushed Nickel (-09) plated finish
- Antique Bronze (-20) hand painted finish
- Steel construction
- Six feet of 9 gauge chain supplied.
- Companion Bath and Vanity, Chandelier, Close to ceiling, Hall and Foyer, Pendant, Wall Bracket, fixtures are available

Mounting

- Ceiling chain mount
- Canopy covers a standard 4" hexagonal recessed outlet box
- Mounting strap for outlet box included
- Threaded socket ring secures glass

Electrical

- Medium base ceramic sockets
- 15 feet of wire supplied
- Pre-wired

Labeling

- UL-CUL listed



Compact Fluorescent

Trinity

Chandelier & Foyer

Energy Star compliant

Type _____

-09EBWB -20EBWB

P4326

Catalog No.	Finish		Lamping	Dimensions (Inches)		
	Brushed Nickel	Antique Bronze		A	B	C
P4326	-09EBWB	-20EBWB	4-13w GU24 CFL (included)	19	20-1/2	95

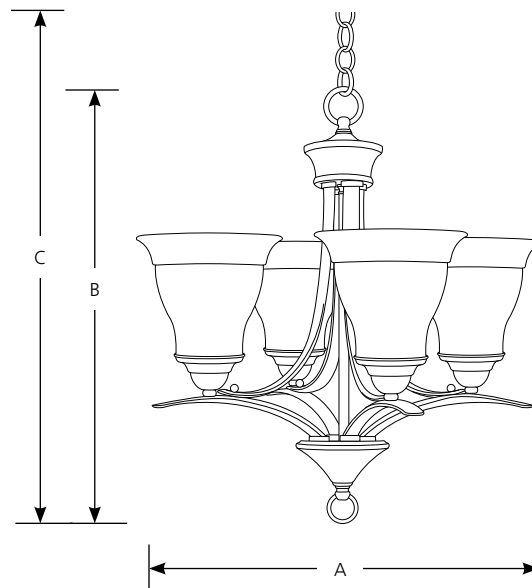

Specifications:

General

- Etched glass shades with slight banding: 6-1/2" dia.
- Uplight style four light chandelier
- Oval tubing with pinched ends
- Brushed Nickel (-09) is plated
- Antique Bronze (-20) is hand painted
- Six feet of 9 gauge chain supplied.
- Four 13w GU24 CFL self-ballasted lamps (included)
- Steel construction
- Companion Bath and Vanity, Chandelier, Close to ceiling, Hall and Foyer, Pendant, Wall Bracket, fixtures are available
- Energy Star Certified

Mounting

- Ceiling chain mount
- Canopy covers a standard 4" hexagonal recessed outlet box
- Mounting strap for outlet box included
- Threaded socket ring secures glass

Electrical

- GU24 base sockets
- 15 feet of wire supplied
- Pre-wired

Labeling

- cCSAus listed



Progress Lighting
701 Millennium Blvd.
Greenville, South Carolina
29607

www.progresslighting.com

Rev. 03/13