

Type	_____	
	-10	-30
P3652	<input type="checkbox"/>	<input type="checkbox"/>
P3653	<input type="checkbox"/>	<input type="checkbox"/>
P3654	<input type="checkbox"/>	<input type="checkbox"/>

Catalog No.	Finish		Lamping	Dimensions (Inches)	
	Polished Brass	White		A	B
P3652	-10	-30	2 (m) 60w	10-1/2	6-1/2
P3653	-10	-30	2 (m) 75w	12-1/2	7-1/4
P3654	-10	-30	3 (m) 60w	14-1/2	7-3/4

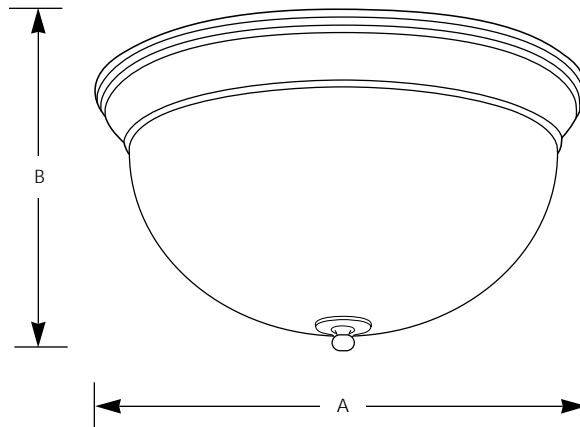

Specifications:

General

- Steel construction
- Plated Polished Brass (-10) or White painted (-30) finishes
- Steel pan
- White glass
- Glass has center lock up for maintenance
- Fiberglass insulated

Electrical

- Requires 90-degree supply wire connections
- Porcelain medium based sockets
- Pre-wired

Labeling

- UL-CUL listed

Mounting

- Ceiling mount
- Covers outlet box
- Mounting strap for outlet box included
- Keyhole slots for easy mounting

P3652

WHITE GLASS - FLUSH MOUNT

Report No. 2000031

No. Lamps: 2 Type Lamp: 60A19-GE Total Lumens: 1730

Fixture Efficiency: 64.8%

S/MH Ratio: 1.3

Quick Calculator Charts

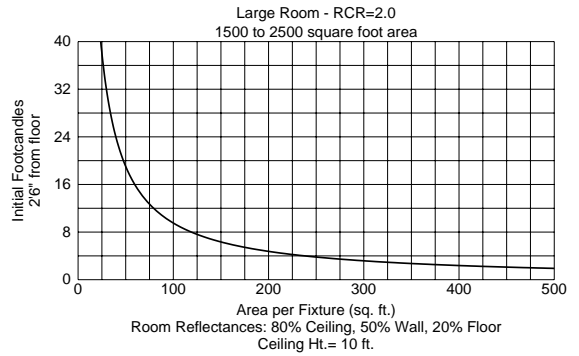
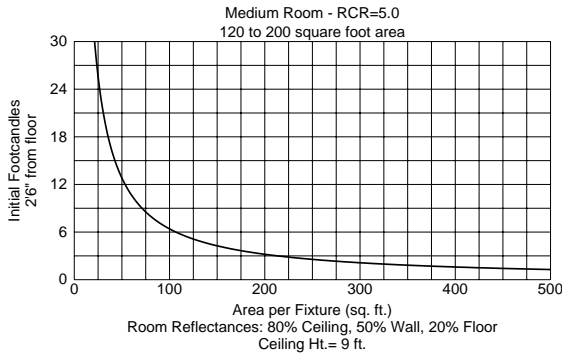

DISTRIBUTION CURVE

INTENSITY DATA

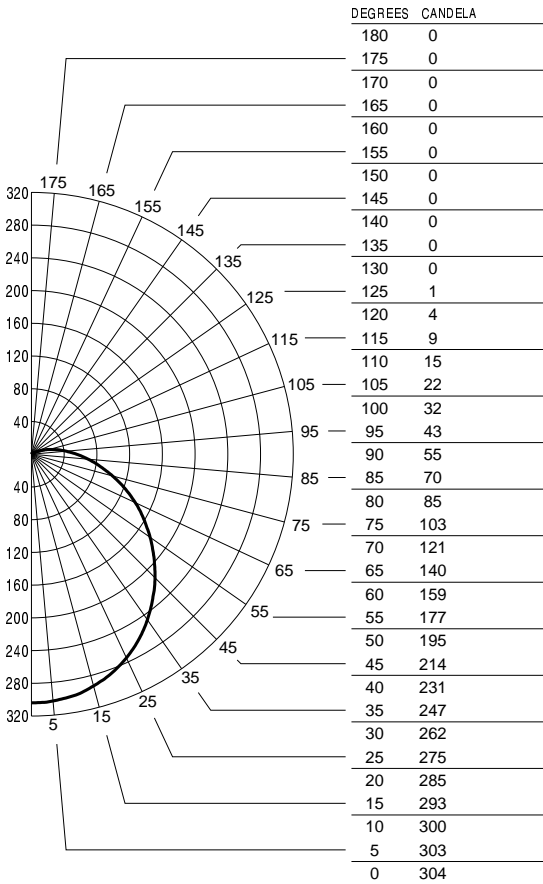

Single Fixture Data

Ceiling Ht.(Ft.)	10% Values		Zero Degrees	50% Values	
	Beam Angle - 112			Beam Angle - 65	
	Ft.-C	Beam Dia.		Ft.-C	Beam Dia.
8	1.0	16	10.0	5.0	7
10	0.5	22	5.4	2.7	10
12	0.3	28	3.4	1.7	12
14	0.2	34	2.3	1.1	15
16	0.2	40	1.7	0.8	17

Ft.-C (Footcandles) are initial and measured 2'-6" from floor

ZONAL CAVITY COEFFICIENTS OF UTILIZATION

Effective Floor Cavity Reflectance 0.20

RC	80				70				50				30				10				0			
	70	50	30	10	70	50	30	10	50	30	10	50	30	10	50	30	10	50	30	10	0			
0	76	76	76	76	74	74	74	74	69	69	69	66	66	66	62	62	62	60	60	60	60			
1	68	64	61	57	65	62	59	56	58	56	53	55	53	51	52	50	49	47	47	47	47			
2	61	55	50	46	59	53	49	45	50	46	43	47	44	41	45	42	40	38	38	38	38			
3	55	48	42	37	53	46	41	37	44	39	35	41	37	34	39	36	33	31	31	31	31			
4	50	42	36	31	48	41	35	31	39	34	30	36	32	29	34	31	28	26	26	26	26			
5	46	37	31	27	44	36	31	26	34	29	25	33	28	25	31	27	24	22	22	22	22			
6	43	34	27	23	41	33	27	23	31	26	22	29	25	22	28	24	21	20	20	20	20			
7	39	30	24	20	38	30	24	20	28	23	20	27	22	19	25	22	19	17	17	17	17			
8	37	28	22	18	35	27	22	18	26	21	17	24	20	17	23	19	17	15	15	15	15			
9	34	25	20	16	33	25	19	16	24	19	16	23	18	15	22	18	15	14	14	14	14			
10	32	23	18	15	31	23	18	14	22	17	14	21	17	14	20	16	14	12	12	12	12			