

Type \_\_\_\_\_

-09    -74

P3854       

Catalog No.	Finish		Lamping	Dimensions (Inches)	
	Brushed Nickel	Venetian Bronze		A	B
P3854	-09	-74	1 (m) 100w	12-1/2	6-1/8

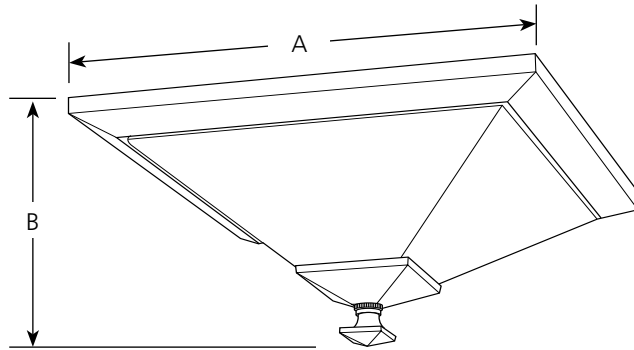

**Specifications:**

General

- Square etched glass inverted shade: 10-1/4" sq. x 3-3/8" ht.
- Plated Brushed Nickel (-09) or painted Venetian Bronze (-74) finish
- Steel Construction
- Companion foyer, chandelier, pendant, close to ceiling and bath and vanity units

Mounting

- Ceiling flush mounted
- Unit covers a standard 4" recessed octagonal outlet box
- Mounting strap for outlet box included

Electrical

- Medium based ceramic sockets
- Pre-wired

Labeling

-  damp location listed