

PORCHER®

ASSEMBLY & INSTALLATION INSTRUCTIONS

Archive Circular Vanity 89280



INTRODUCTION

Thank you for selecting our Porcher product. To ensure that your installation proceeds smoothly, read these instructions carefully before you begin. Also, review the recommended tools and materials section. Carefully unpack and examine your new plumbing fixture.

ALL INSTALLATION PROCEDURES MUST COMPLY IN STRICT ACCORDANCE WITH APPLICABLE LOCAL PLUMBING AND BUILDING CODES

Tools and Materials Required

Most of the procedures require the use of common tools and materials, which are available from hardware and plumbing, supply stores. It is essential that the tools and materials be on hand before work is begun.

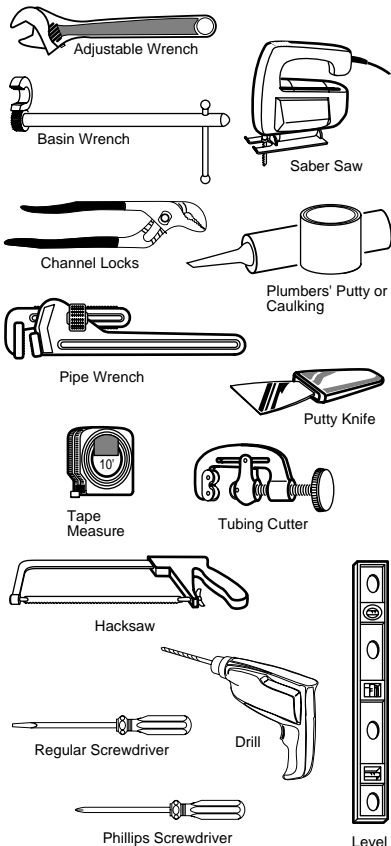

Roughing-in Dimensions

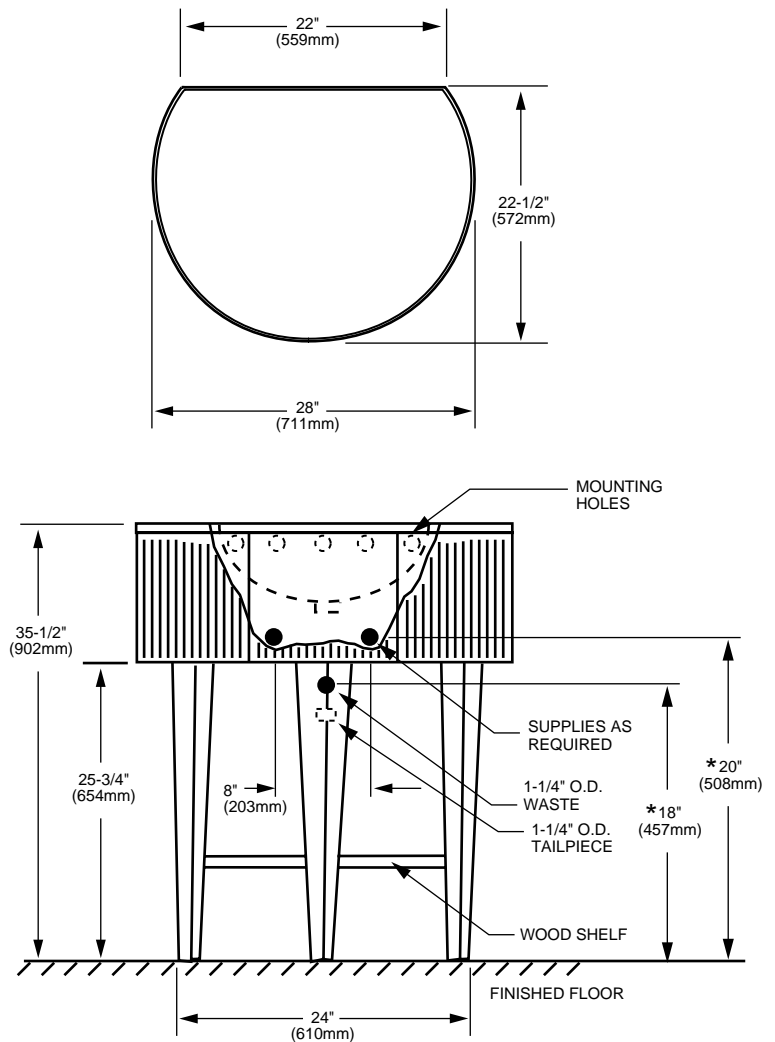

*Dimensions shown for location of supplies and "P" trap are suggested.

Provide suitable reinforcement required for anchoring the vanity to the wall. *Determine horizontal centerline location of support from fixture.

If molding is present, either notch the molding to seat the vanity flush against the wall or provide suitable spacer.

Rough in supply lines and waste per rough in dimensions.
NOTE: If current supply lines are greater than 8" on center, they may interfere with cutout in rear of vanity or vanity shelf.

Remove the wood top from the vanity. The top is held in place from the underside by 4 screws, 1 through each of the 4 angled corner braces.

Move the vanity into place and anchor it to the wall through at least 2 of the mounting holes in the rear of the vanity.

Continue with installation appropriate for top and sink options chosen.

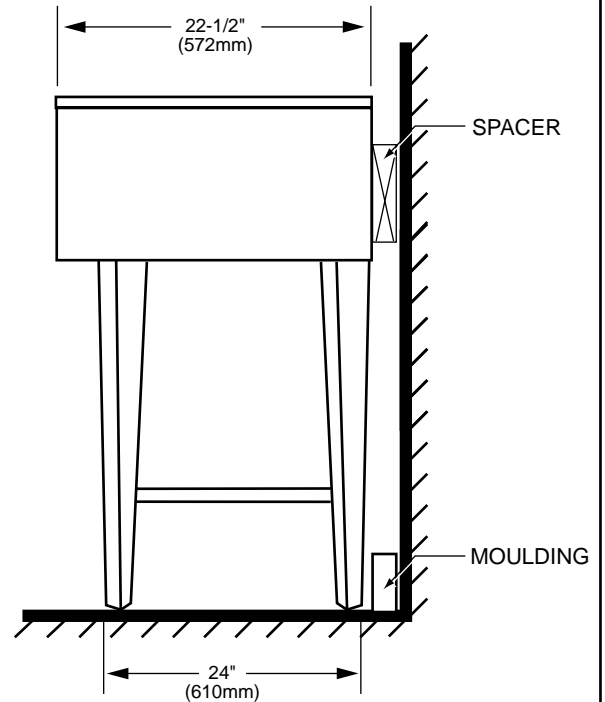
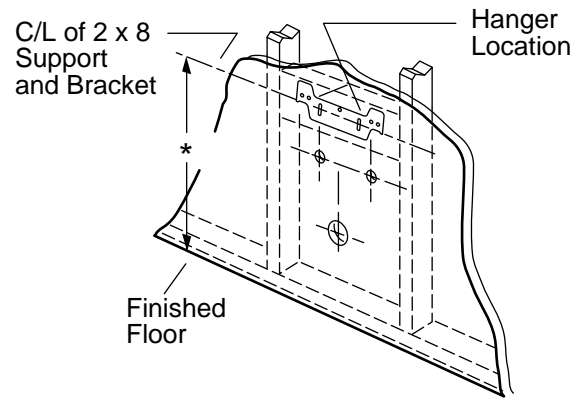

If Using Wood Top...

Determine which sink is being installed and follow the instructions printed on the appropriate template for cut-out, faucet installation, sink installation and replacement of vanity top. NOTE: American Standard is not responsible for cut-out errors when the incorrect cut-out template is used.

Use the manufacturers installation instructions to install drop-in or undercounter lavatory.

After top is replaced, connect the trap to the drain assembly hand tight to check alignment. It may be necessary to cut off part of the tailpiece (area "A") or part horizontal leg of the trap (area "B").

Connect hot and cold supply lines to the shut off valves. Tighten trap joints for watertight assembly.

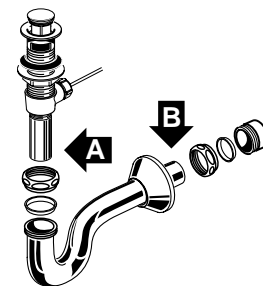

Typical Drain Assembly

If using optional marble top 89808.00.550 with Carrera 11070 undermount sink...

NOTE: Marble top comes pre-cut for the Carrera under counter mount sink and 8" faucet spread.

Install faucet and drain in accordance with manufacturer's instructions. Ensure all water supply and drain connections are tightened. Turn on water supply valves and water-test installation.

Turn the marble top upside down and place it on a clean, scratch resistant surface. Apply a bead of silicone adhesive to the rim of the sink. Center the sink over the cutout and secure it to the top using the mounting kit provided.

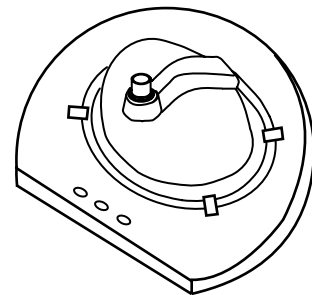
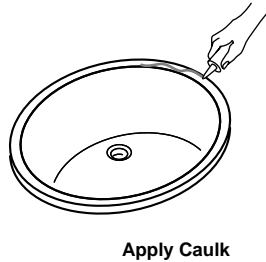
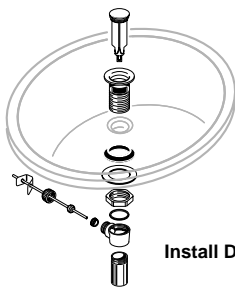
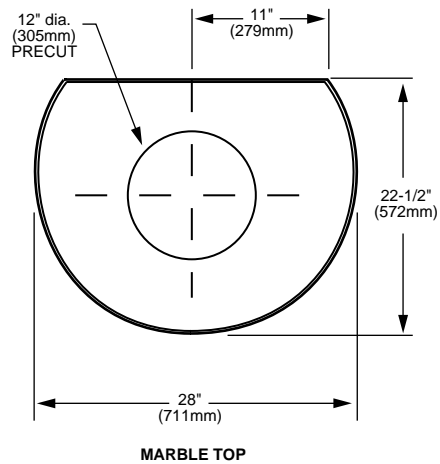

Turn the top right-side up and install the faucet per the manufacturer's instructions.

Apply a bead of silicone adhesive to the rim of the vanity. Place the marble top centered left to right on the vanity and with the back edge of the top even with the rear of the vanity.

Connect the trap to the drain assembly hand tight to check alignment. It may be necessary to cut off part of the tailpiece (area "A") or part horizontal leg of the trap (area "B").

Connect hot and cold supply lines to the shut off valves. Tighten trap joints for watertight assembly.

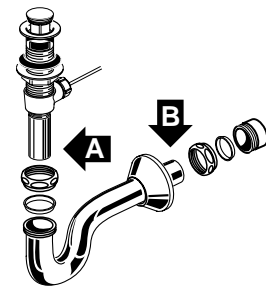

Care and Cleaning of Vanity

Please note that some chemicals may damage the finish on the frame. Take care to avoid having the frame come into contact with the following: iodine, hair dye, after shave lotion, Lestoil[®], Lysol Tub and Tile Cleaner[®], Lysol Spray Disinfectant[®], Dow Disinfectant[®], acetone, paint remover, Formula 409[®], Tile-X[®], and Nair[®]. Use the Milsek Furniture Polish and Cleaner[®] (sample included) to care for the support frame and panels.

Care and Cleaning of the Marble Vanity Top

A solution of 1/4 part vinegar and 3/4 parts water is excellent for general cleaning of your stone table top. Do not use abrasive or thick cream cleaning solutions. Common stains such as red wine or mustard should not remain on the stone top for an extended length of time.

PORCHER FURNITURE LIMITED WARRANTY

If inspection of this Porcher plumbing product, within one year after its initial purchase, confirms that it is defective in materials or workmanship, Porcher will repair or, at its option, exchange the product for a similar model. Variations in actual wood color and finishes which may result from natural characteristics of the wood, such as grain patterns, mineral streaks and the like, are not defects and are not covered by this warranty.

This warranty applies only to the original purchaser and installation of these products. In the event of a claim, proof of purchase will be required; save your receipt.

This limited warranty **does not apply** to local building code compliance. Since local building codes vary considerably, the purchaser of this product should check with a local building or plumbing contractor to insure local code compliance before installation.

This warranty **is void** if the product has been moved from its initial place of installation; if it has been subjected to faulty maintenance, abuse, misuse, accident or other damages; if it was not installed in accordance with Porcher's instructions; or if it has been modified in a manner inconsistent with the product as shipped by Porcher.

Porcher's option to repair or exchange the product under this warranty does not cover any labor or other costs of removal or installation, nor shall Porcher be responsible for any other incidental or consequential damages attributable to a product defect or to the repair or exchange of a defective product, all of which are expressly excluded from this warranty. This limited warranty **does not** cover any liability for consequential or incidental damages, all of which are hereby expressly disclaimed, or the extension beyond the duration of this limited warranty of any implied limited warranties, including those of merchantability or fitness for an intended purpose. (Some states or provinces do not allow the exclusion or limitation of implied warranties, so this exclusion may not apply to you).

This warranty gives you specific legal rights. You may have other statutory rights that vary from state to state or province to province, in which case this warranty does not affect such statutory rights.

PORCHER GLASS AND/OR STONE PRODUCTS LIMITED WARRANTY

If inspection of this Porcher plumbing product, within one year after its initial purchase, confirms that it is defective in materials or workmanship, Porcher will repair or, at its option, exchange the product for a similar model. Variations in shading, veining, and texture which may result from natural characteristics of stone and as such are not defects and are not covered by this warranty.

This warranty applies only to the original purchaser and installation of these products. In the event of a claim, proof of purchase will be required; save your receipt.

This limited warranty **does not** apply to local building code compliance. Since local building codes vary considerably, the purchaser of this product should check with a local building or plumbing contractor to insure local code compliance before installation.

This warranty **is void** if the product has been moved from its initial place of installation; if it has been subjected to faulty maintenance, abuse, misuse, accident or other damages; if it was not installed in accordance with Porcher's instructions; or if it has been modified in a manner inconsistent with the product as shipped by Porcher.

Porcher's option to repair or exchange the product under this warranty does not cover any labor or other costs of removal or installation, nor shall Porcher be responsible for any other incidental or consequential damages attributable to a product defect or to the repair or exchange of a defective product, all of which are expressly excluded from this warranty. This limited warranty **does not** cover any liability for consequential or incidental damages, all of which are hereby expressly disclaimed, or the extension beyond the duration of this limited warranty of any implied limited warranties, including those of merchantability or fitness for an intended purpose. (Some states or provinces do not allow the exclusion or limitation of implied warranties, so this exclusion may not apply to you).

This warranty gives you specific legal rights. You may have other statutory rights that vary from state to state or province to province, in which case this warranty does not affect such statutory rights.

For service under these warranties, it is suggested that a claim be made through the contractor or dealer from or through whom the product was purchased, or that a service request (including a description of the product model and of the defect) be sent to the following address:

In the United States:

Porcher
P.O. Box 6820
Piscataway, New Jersey, 08855
Attention: Director of Consumer Affairs

For residents of the United States, warranty information may also be obtained by calling the following toll free number: (800) 359-3261

In Canada:

Porcher
2480 Stanfield Road
Mississauga, Ontario
Canada L4Y 1S2

Toronto Area: (905) 306-1093
Toll Free: (800) 387-0369

In Mexico:

Porcher
Planta Santa Clara
Via Morelos #330
Santa Clara Coatitla
Ecatepec de Morelos 55540,
Estado de Mexico, Mexico