

Highlights

- Ceramic Disc Valves
- WaterSense Compliant
- Pforever Warranty®

Code Compliance

Price Pfister products are designed and manufactured in compliance with the following standards and codes:

- IAPMO certified • ASME A112.18.1
- CSA B125 certified • ANSI A117.1 (Lever handles only)

49 Series

Park Avenue™

8”-15” Widespread Faucet

- Lever Handles
- 3-Hole Installation
- Ceramic Disc Valves

Finishes	GT 49-FE0C	GT 49-FE0D	GT 49-FE0K	GT 49-FE0Y
Tuscan Bronze				X
Polished Chrome	X			
Brushed Nickel			X	
Polished Nickel		X		

Features	GT 49-FE0C	GT 49-FE0D	GT 49-FE0K	GT 49-FE0Y
Quick Connect Installation	X	X	X	X
1.5 GPM Flow Rate	X	X	X	X
Lever Handles	X	X	X	X
3-Hole Installation	X	X	X	X
8”-15” Variable Installation	X	X	X	X
Metal Pop-Up	X	X	X	X
WaterSense Compliant	X	X	X	X
Pforever Warranty®	X	X	X	X

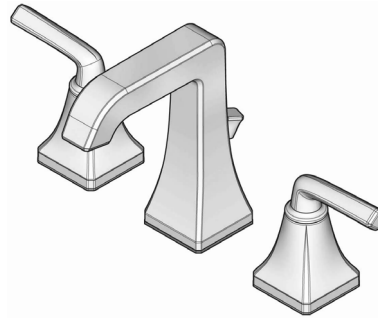

- GT49-FE0C
- GT49-FE0D
- GT49-FE0K
- GT49-FE0Y

For additional information, please contact your Price Pfister representative, or visit our website at www.pricepfister.com.

Project: _____

Contractor: _____

SS-049-FE-1

1-800-PFAUCET www.pricepfister.com
 19701 DaVinci, Lake Forest, CA 92610
 02/15/11

