

Specification Submittal Data / Panasonic Ventilation Fan

Description

Ventilating fan shall be Low Noise ceiling mount type rated for continuous run. Fan shall be ENERGY STAR® rated and certified by the Home Ventilating Institute (HVI). Fan shall include energy efficient compact fluorescent lighting. Evaluated by Underwriters Laboratories and conform to both UL and cUL safety standards.

Motor/Blower:

- Enclosed DC brushless motor technology rated for continuous run.
- Power Rating shall be 120 volts and 60 Hz.
- Fan shall be UL listed for tub/shower enclosure when used with a GFCI protected circuit and used in insulated ceiling (TYPE I.C.).
- Motor equipped with thermistor high limit control.
- Removable with permanently lubricated plug-in motor.

Housing:

- Rust proof paint, galvanized steel body.
- Integrated dual 4" or 6" diameter duct adaptor.
- Built-in metal flange provides blocking for penetrations through drywall as an Air Barrier, and assists with the decrease in leakage in the Building Envelope during blower door testing.
- Built in backdraft damper.
- Double hanger bar system allowing for ideal positioning.



* (2) 13W self-ballasted GU24 base CFL lamps included

Light:

- Two 13 Watt self-ballasted GU24 base compact fluorescent lamps included.
- One 4-watt, night-light included.
- FCC Part 18 compliant.

Warranty:

- ALL Parts: For period of 3 years from the date of the original purchase. DC Motor: For period of 6 years from the date of the original purchase. Compact Fluorescent Lamps (CFL): 1 year. Night Light Lamp: No warranty.

Architectural Specifications:

Ventilation fan, light and night-light combination shall be ceiling mount, ENERGY STAR rated type, with no less than 80 CFM and no more than <0.3 sone as certified by the Home Ventilating Institute (HVI) at 0.1 static pressure in inches water gauge (w.g.) with no less than 79 CFM and no more than 0.6 sone as certified by HVI at .25 w.g. Power Consumption shall be no greater than 7.4 watts at 0.1 w.g. and 12.4 watts at 0.25 w.g. ENERGY STAR rated with efficiency of no less than 11.2 CFM/watt at 0.1 w.g. and than 6.6 CFM/watt at 0.25 w.g. The motor shall be enclosed with brushless DC motor engineered to run continuously. Power rating shall be 120v/60Hz. Included is an integrated dual 4" or 6" diameter duct adaptor. Duct diameter shall be no less than 4". Fan shall be UL and cUL listed for tub/shower enclosure when used with a GFCI protected circuit. Fan can be used to comply with ASHRAE 62.2, LEED, ENERGY STAR IAP, EarthCraft, California Title-24, and WA Ventilation Code. Lamps shall be of the compact fluorescent type with the fan utilizing no less than two 13W, ESTAR rated, self-ballasted GU24, base compact fluorescent lamps. Night-light feature shall be included.

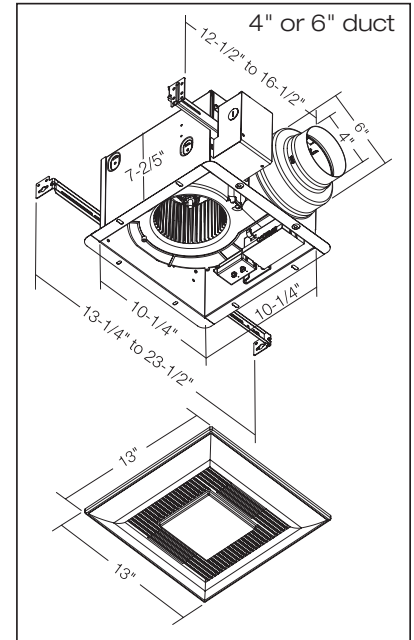

FV-08VKL4

DC Motor Technology:

When fan faces static pressure, its speed is automatically increased to ensure that the desired CFM is not compromised, which allows the fan to perform as rated.

Specifications: WhisperGreen-Lite FV-08VKL4	4" or 6" Duct (Standard)	
Static Pressure in inches w.g.	0.1	0.25
Air Volume (CFM)	80	79
Noise (sones)	<0.3	0.6
Power Consumption (watts)	7.4	12.4
Energy Efficiency (CFM/Watt)	11.2	6.6
Speed (RPM)	866	1166
Power Rating (V/Hz)	120/60	
ENERGY STAR rated	YES	

0.25=Installed Performance

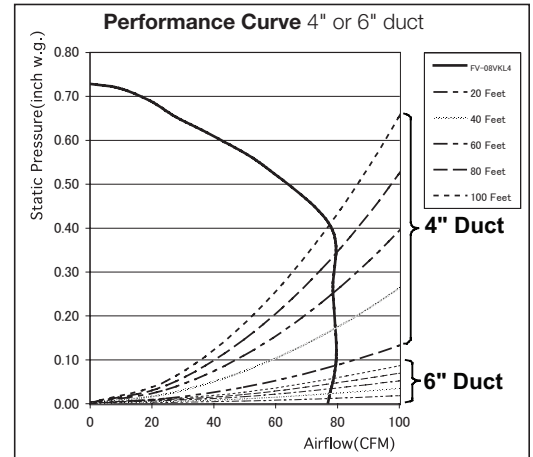

For complete Installation Instructions visit us.panasonic.com/ventfans

Model	Quantity	Comments	Project:
			Location:
			Architect:
			Engineer:
			Contractor:
			Submitted by:
			Date:

Panasonic Eco Solutions North America
Eco Products Division
Two Riverfront Plaza
Newark, NJ 07102

us.panasonic.com/ventfans

