

**Specification Submittal Data / Panasonic Ventilation Fan**

**Description**

Ventilating fan shall be Low Noise ceiling mount type rated for continuous run. Fan shall be ENERGY STAR® rated and certified by the Home Ventilating Institute (HVI). Fan shall include energy efficient compact fluorescent lighting. Evaluated by Underwriters Laboratories and conform to both UL and cUL safety standards.

**Motor/Blower:**

- Totally enclosed DC brushless motor technology rated for continuous run.
- Power Rating shall be 120 volts and 60 Hz.
- Fan shall be UL listed for tub/shower enclosure when used with a GFCI protected circuit and used in insulated ceiling (TYPE I.C.)
- Motor equipped with thermistor high limit control.
- Removable with permanently lubricated plug-in motor.

**Housing:**

- Rust proof paint, galvanized steel body.
- 6" diameter duct adaptor.
- Built-in metal flange provides blocking for penetrations through drywall as an Air Barrier, and assists with the decrease in leakage in the Building Envelope during blower door testing.
- Built-in backdraft damper.
- Expandable extension bracket up to 24".
- Double hanger bar system allowing for ideal positioning.



\*(2) 13W self-ballasted GU24 base CFL lamps bulbs included

**Grille:**

- Attractive design using PP material.
- Attaches directly to housing with torsion springs.

**Light:**

- Two 13 Watt self-ballasted GU24 compact fluorescent lamps included.
- One 4-Watt night-light included.
- FCC Part 18 compliant.

**Warranty:**

- ALL Parts: For period of 3 years from the date of the original purchase. DC Motor: For period of 6 year from the date of the original purchase. Compact Fluorescent Lamp (CFL): 1 year. Night Light Lamp: No warranty.

**Architectural Specifications:**

Ventilation fan, light and night-light combination shall be ceiling mount, ENERGY STAR rated type, with variable speed control that shall be built-in with a high/low delay timer and activated by a switch, with no less than 130 CFM and no more than 0.8 sone as certified by the Home Ventilating Institute (HVI) at 0.1 static pressure in inches water gauge (w.g.) with no less than 137 CFM and no more than 1.3 sone as certified by HVI at .25 w.g. Power Consumption shall be no greater than 14.2 watts at 0.1 w.g. and 24.2 watts at 0.25 w.g. ENERGY STAR rated with efficiency of no less than 9.0 CFM/watt at 0.1 w.g. and than 5.5 CFM/watt at 0.25 w.g. The motor shall be enclosed with brushless DC motor engineered to run continuously. Power rating shall be 120v/60Hz. Duct diameter shall be no less than 6". Fan shall be UL and cUL listed for tub/shower enclosure when used with a GFCI protected circuit. Fan can be used to comply with ASHRAE 62.2, LEED, ENERGY STAR IAP, EarthCraft, California Title-24 and WA Ventilation Code. Lamps shall be of the compact fluorescent type with the fan utilizing no less than two 13 Watt, ESTAR rated self-ballasted GU24 base compact fluorescent lamps. Night-light feature shall be included.

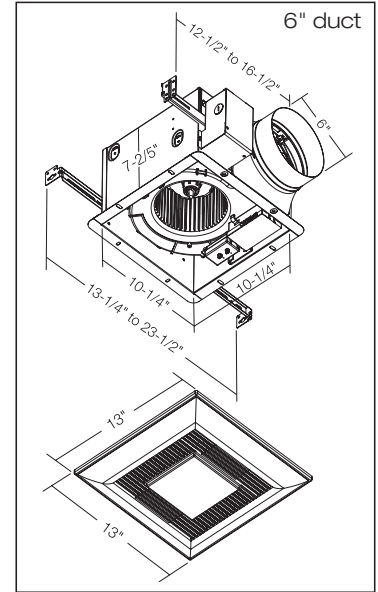

FV-13VKSL4

**DC Motor Technology:**

- Allows the fan to run continuously at a pre-set lower level (0, 30 – 70 CFM). The fan then elevates to a maximum level of operation (80 CFM) when wall mount switch is activated.
- When fan faces static pressure, its speed is automatically increased to ensure that the desired CFM is not compromised, which allows the fan to perform as rated.

Specifications: <b>WhisperGreen-Lite</b> FV-13VKSL4 - 6" Duct										
Static Pressure in inches w.g.	0.1	0.25	0.1	0.25	0.1	0.25	0.1	0.25	0.1	0.25
Air Volume (CFM)	130	137	110	115	90	91	70	69	50	57
Noise (sones)	0.8	1.3	0.6	1.2	0.3	1.1	<0.3	0.9	<0.3	0.8
Power Consumption (watts)	14.2	24.2	10.7	19.4	7.8	14.9	5.9	10.5	4.1	8.5
Energy Efficiency (CFM/Watt)	9.0	5.5	10.1	5.8	11.5	6.1	12.0	6.7	12.3	6.7
Speed (RPM)	742	968	707	972	676	969	669	932	648	939
Current (amps)	0.04	0.15	0.05	0.12	0.03	0.09	0.03	0.01	0.04	0.01
Power Rating (V/Hz)	120/60									
ENERGY STAR rated	Yes									

0.25=Installed Performance

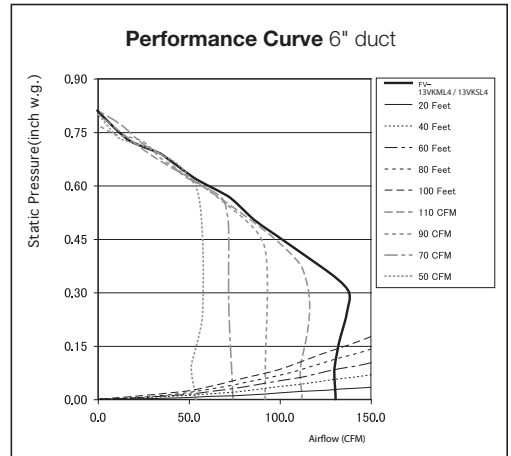

For complete Installation Instructions visit [us.panasonic.com/ventfans](http://us.panasonic.com/ventfans)

Model	Quantity	Comments	Project:
			Location:
			Architect:
			Engineer:
			Contractor:
			Submitted by:
			Date:

**Panasonic Eco Solutions Company of North America**  
Eco Products Division  
Two Riverfront Plaza  
Newark, NJ 07102

[us.panasonic.com/ventfans](http://us.panasonic.com/ventfans)

