

4

3

2

1

BILL OF MATERIAL (CURRENT LEVEL)

ITEM	PT/ASSY	DESCRIPTION	TYPE	QTY.
1	1-504	BP VALVE ASM W/O DIVERTER	ASSEMBLY	1
2	3-904BP	BALANCE PRESSURE SET	ASSEMBLY	1

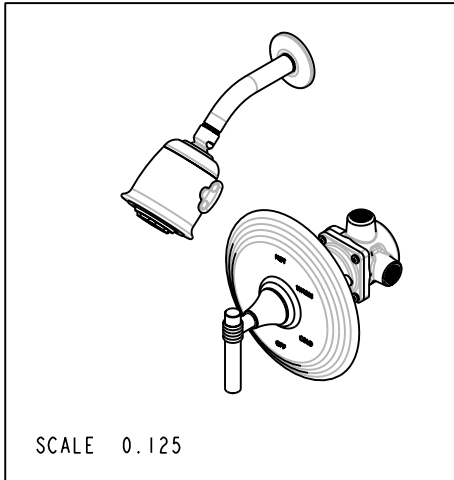
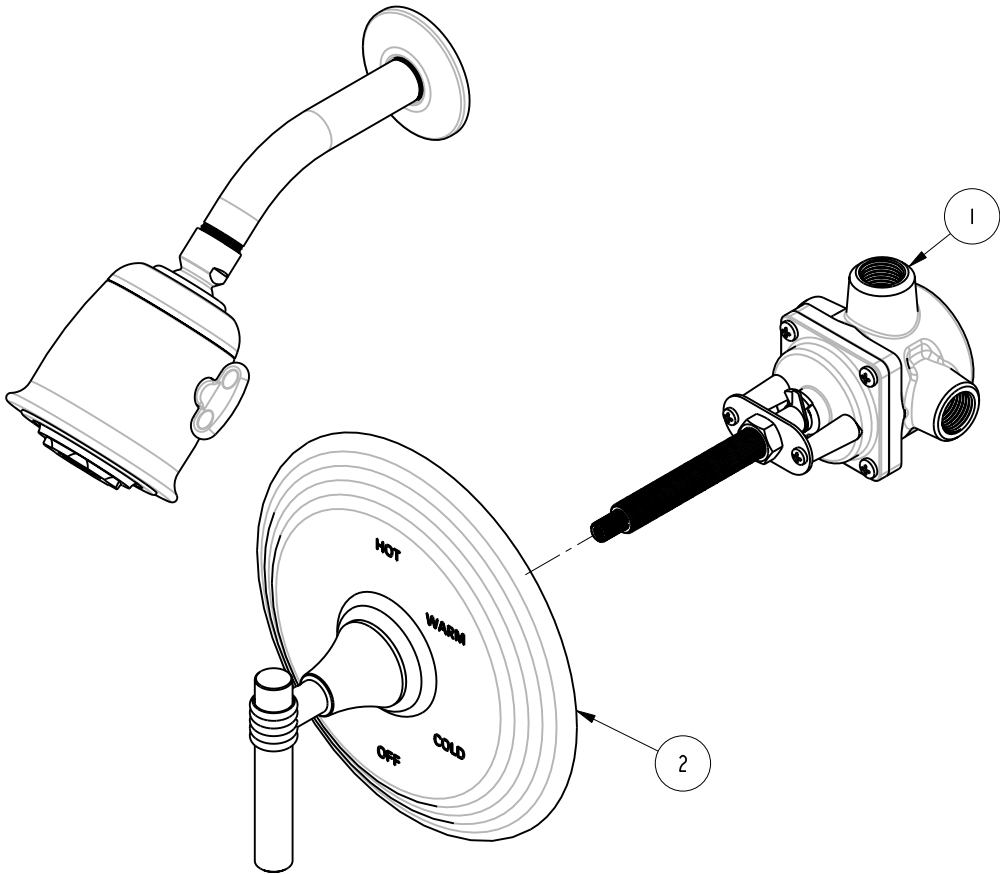

D

C

B

A

D

C

B

A

COPYRIGHT 2005 BRASSTECH, INC. THESE DRAWINGS AND THE DESIGNS DEPICTED HEREIN ARE THE PROPRIETARY PROPERTY OF BRASSTECH. ANY USE OR REPRODUCTION IS SUBJECT TO THE EXPRESS APPROVAL OF BRASSTECH. UNAUTHORIZED USE IS STRICTLY PROHIBITED. ALL RIGHTS RESERVED.

BRASSTECH
 INCORPORATED
 2001 E. CARNEGIE AVE.
 SANTA ANA, CA 92705
 (949) 417-5207

SHOWER SET

ASSY. NO. 904BP

SCALE 0.300	REF. -	SHEET 1 OF 3	REV	REV DESC	DATE
-------------	--------	--------------	-----	----------	------

4

3

2

1

4

3

2

1

BILL OF MATERIAL (CURRENT LEVEL)

ITEM	PT/ASSY	DESCRIPTION	TYPE	QTY.
1	200	SHOWER ARM 6" BRASS	PART	1
2	206	SHOWER ARM FLANGE 2.5	PART	1
3	2131	BELL SHOWERHEAD	ASSEMBLY	1
4	2-225	BP COVER PLATE FOR SHOWER	ASSEMBLY	1
5	3-187H	TRIM KIT - HANDLE/ESCUTCHEON	ASSEMBLY	1

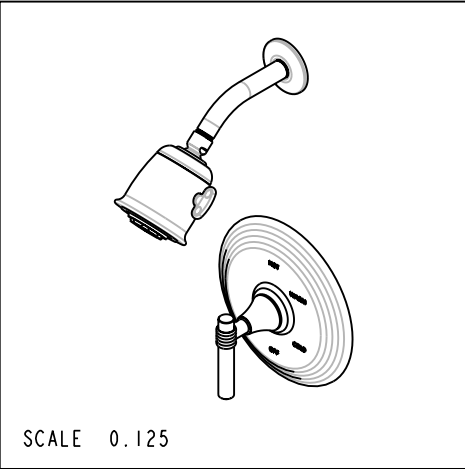
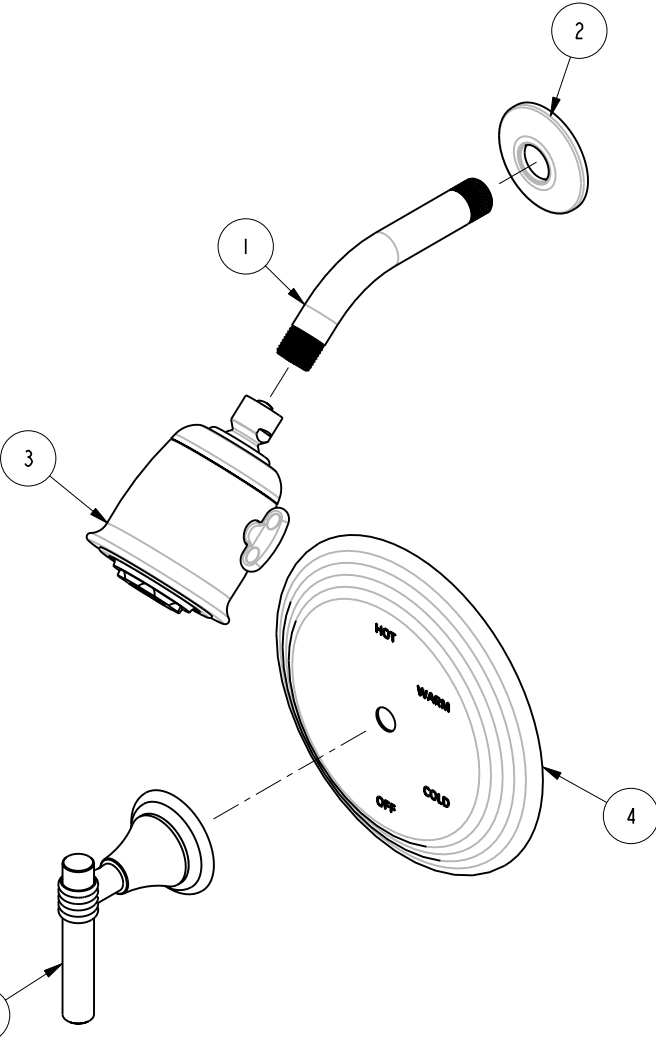

D

D

C

C

B

B

A

A

COPYRIGHT 2005 BRASSTECH, INC. THESE DRAWINGS AND THE DESIGNS DEPICTED HEREIN ARE THE PROPRIETARY PROPERTY OF BRASSTECH. ANY USE OR REPRODUCTION IS SUBJECT TO THE EXPRESS APPROVAL OF BRASSTECH. UNAUTHORIZED USE IS STRICTLY PROHIBITED. ALL RIGHTS RESERVED.

BRASSTECH
 INCORPORATED
 2001 E. CARNEGIE AVE.
 SANTA ANA, CA 92705
 (949) 417-5207

BALANCE PRESSURE SET

ASSY. NO. 904BP		A	EO-0224	07/01/03
SCALE 0.250		-	RELEASED	03/97
REF. -	SHEET 2 OF 3	REV	REV DESC	DATE

4

3

2

1

