

NOTES:

1. TO INSPECT ASSEMBLY, FOLLOW FIRST ARTICLE AND IN PROCESS INSPECTION SHEET.

**BILL OF MATERIAL (CURRENT LEVEL)**

ITEM	PT/ASSY	DESCRIPTION	TYPE	QTY.
1	2-100	ESCUTCHEON - ASSEMBLY	ASSEMBLY	1
2	10620	BONNET	PART	1
3	2-110	CROSS HANDLE ASM	ASSEMBLY	1
4	10192	HEX KEY TOOL, #8 5/64	PART	1

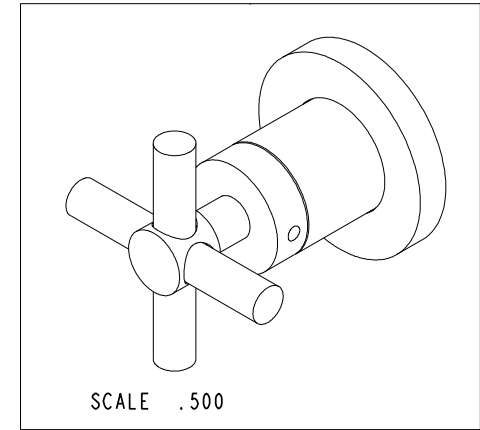
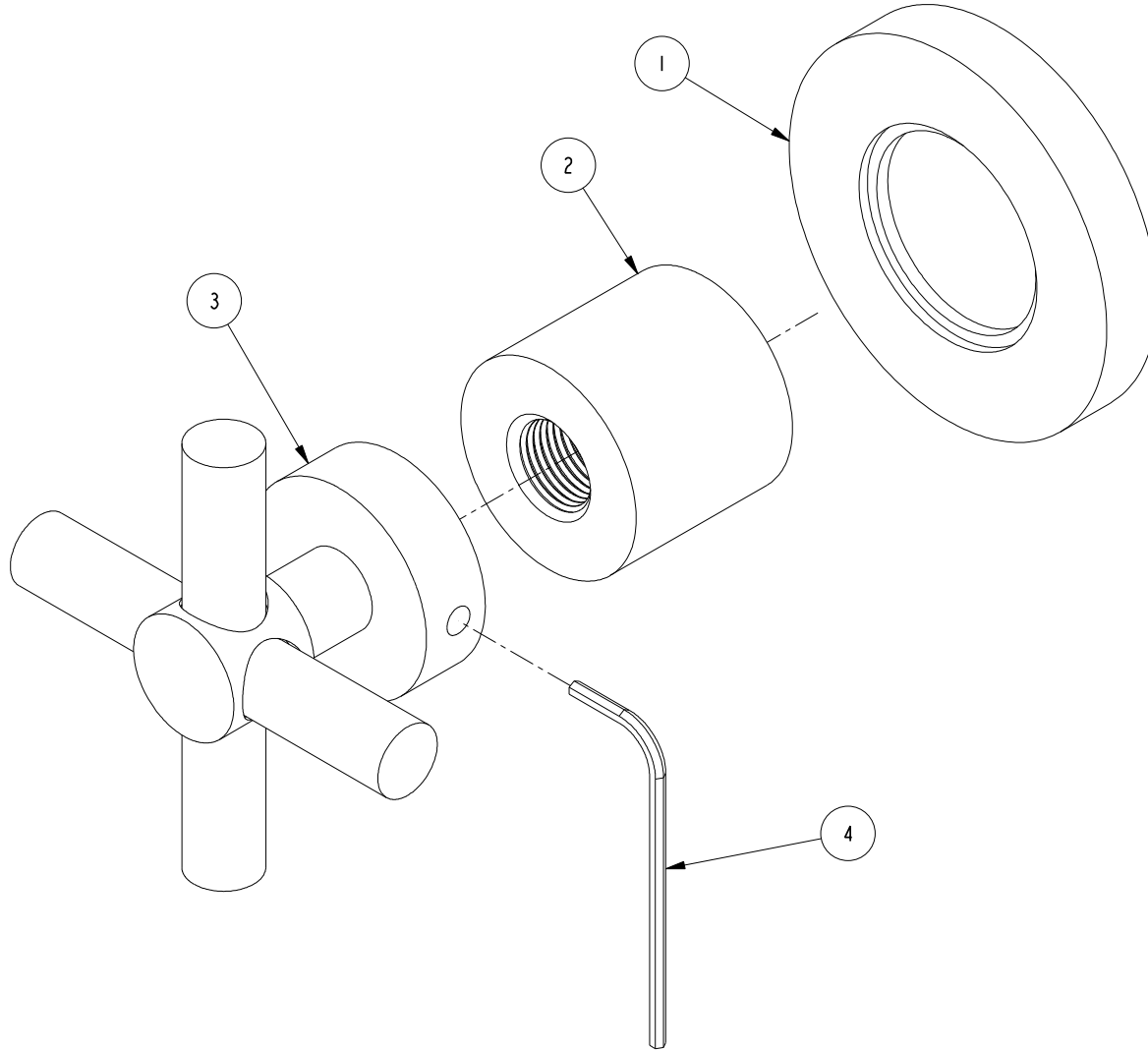

ZONE	REV	DESCRIPTION	DATE	APPROVED
-	B	EN-4300j	12/16/20	R.S.
-	A	EN-2032	01/07/14	-
-	-	RELEASED	-	-

COPYRIGHT 2005 BRASSTECH, INC. THESE DRAWINGS AND THE DESIGNS DEPICTED HEREIN ARE THE PROPRIETARY PROPERTY OF BRASSTECH. ANY USE OR REPRODUCTION IS SUBJECT TO THE EXPRESS APPROVAL OF BRASSTECH. UNAUTHORIZED USE IS STRICTLY PROHIBITED. ALL RIGHTS RESERVED.

TESTING	-	-	-
ASSEMBLY	-	-	-
PLATING	-	1400	1400
POLISHING	-	NEXT ASSY	USED ON
MACHINING	-	APPLICATION	
TOOLING FIXTURE #	REMOVE ALL BURRS AND SHARP EDGES		

UNITS ARE: INCHES [MM]		
TOLERANCES ARE:		
FRACTIONS	DECIMALS	ANGLES
±1/16"	.X ±.1 [2.5]	±1°
	.XX ±.06 [1.5]	
(X.XXX) DENOTES CRITICAL DIMS. ALL THREADS ARE CRITICAL		
DRAWN	JIMSON	12/16/20
CHECKED	R.S.	12/16/20
APPROVED	R.S.	12/16/20

**BRASSTECH** 2001 CARNEGIE AVE. SANTA ANA, CA 92705 (949) 417-5207  
INCORPORATED

**HANDLE TRIM - STOP VALVE**

DWG NO. **3-227** REV **B**

SCALE 1.000 REF. - SHEET 1 OF 2

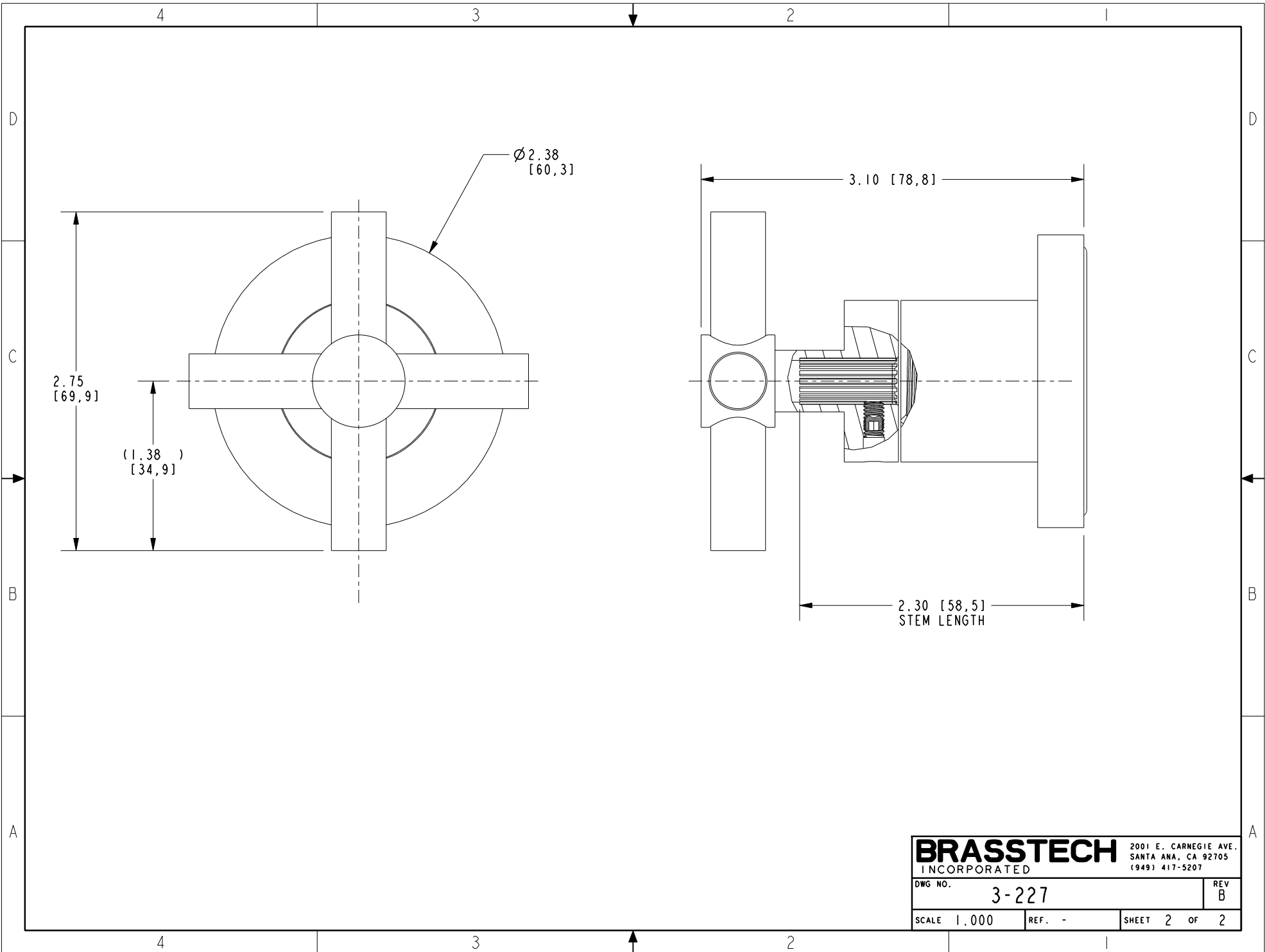

<b>BRASSTECH</b>		2001 E. CARNEGIE AVE. SANTA ANA, CA 92705 (949) 417-5207	
DWG NO.	3-227	REV	B
SCALE	1.000	REF.	-
SHEET		2	OF 2