

NOTES:

1. TO INSPECT ASSEMBLY, FOLLOW FIRST ARTICLE AND IN PROCESS INSPECTION SHEET.

2. APPLY LOCTITE 680.

3. SLIT AND SHORTEN O-RING BY .13" TO .20" IN LENGTH BEFORE INSTALLING.

4. SLIT O-RING BEFORE INSTALLING.

5. INSTALLATION TORQUE: 8 -14 LB-FT.

6. WATER TEST WHOLE UNIT.

7. BAG 5-007 IN A SEPARATE BAG.

8. APPLY THIN FILM OF DOW CORNING 111.

9. APPLY LOCTITE 242.

10. INSTALLATION TORQUE: 10 -14 LB-IN.

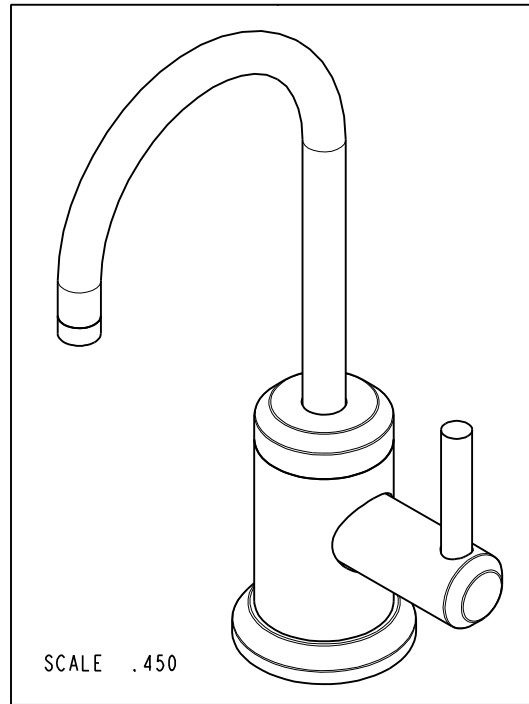

BILL OF MATERIAL (CURRENT LEVEL)

ITEM	PT/ASSY	DESCRIPTION	TYPE	QTY.
1	12649	ESCUTCHEON	PART	1
2	91772	O-RING, # 2-131, EP, 50 DURO - GREY	PART	1
3	50715	WATER DISP BODY (CONT.)	PART	1
4	50717	WATER DISP SPOUT RETAINER	PART	1
5	91023	O-RING, #2- 019, EPDM, 65-75 DURO, NSF 61	PART	1
6	5-052	SPOUT ASM	ASSEMBLY	1
7	91382	O-RING, #2- 012, TEFLON,	PART	1
8	91017	O-RING, #2- 012, EPDM, 65-75 DURO, NSF 61	PART	2
9	12650	BODY CAP	PART	1
10	91383	O-RING, #2- 014, TEFLON, NSF 61	PART	1
11	50714	WATER DISP. CAR.T HOLDER	PART	1
12	12651	WATER DISP HANDLE (CONT.)	PART	1
13	1-134	CARTR 3/8 HOT 1/4 TR	PART	1
14	12750	ADAPTER	PART	1
15	92477	SCRW, M4 X 16 SKT FLT HD SS	PART	1
16	92192	SCRW, 10-32 X 5/8 SKT HD CUP PT SS	PART	1
17	50721	WATER DISP LEVER (CONT.)	PART	1
18	50760	NIPPLE WATER DISP	PART	1
19	5-007	1/4 COMP KIT	ASSEMBLY	1
20	10661	MOUNTING STUD	PART	1
21	91063	MOUNTING CRESCENT GASKET	PART	1
22	10514	MOUNTING CRESCENT	PART	1
23	10516	MOUNTING NUT	PART	1
24	91424	WSHR, .81 ID X .93 OD X .045 THK, FLT, PLST	PART	1

ZONE	REV	DESCRIPTION	DATE	APPROVED
-	D	EN-4300jj	07/22/21	R.S.
-	C	EN-3941	08/28/19	C.G.
-	B	EN-3722	02/08/19	C.G.
-	A	EN-3693	08/29/18	J.M.
-	-	EN-3076	03/17/17	J.M.

COPYRIGHT 2005 BRASSTECH, INC. THESE DRAWINGS AND THE DESIGNS DEPICTED HEREIN ARE THE PROPRIETARY PROPERTY OF BRASSTECH. ANY USE OR REPRODUCTION IS SUBJECT TO THE EXPRESS APPROVAL OF BRASSTECH. UNAUTHORIZED USE IS STRICTLY PROHIBITED. ALL RIGHTS RESERVED.

TESTING	-	-	-
ASSEMBLY	-	-	-
PLATING	-	-	-
POLISHING	-	NEXT ASSY	USED ON
MACHINING	-	APPLICATION	
TOOLING FIXTURE #	REMOVE ALL BURRS AND SHARP EDGES		

UNITS ARE: INCHES [MM]
TOLERANCES ARE:
FRACTIONS DECIMALS ANGLES
±1/16" .X ±.1 [2,5] ±1°
.XX ±.06 [1,5]

(X.XXX) DENOTES CRITICAL DIMS.
ALL THREADS ARE CRITICAL

DRAWN	JINSON	07/22/21
CHECKED	R.S.	07/22/21
APPROVED	R.S.	07/22/21

BRASSTECH 2001 CARNEGIE AVE.
INCORPORATED SANTA ANA, CA 92705
(949) 417-5207

WATER DISPENSER - COLD

DWG NO. **3200-5623** REV **D**

SCALE .250 REF. - SHEET 1 OF 3

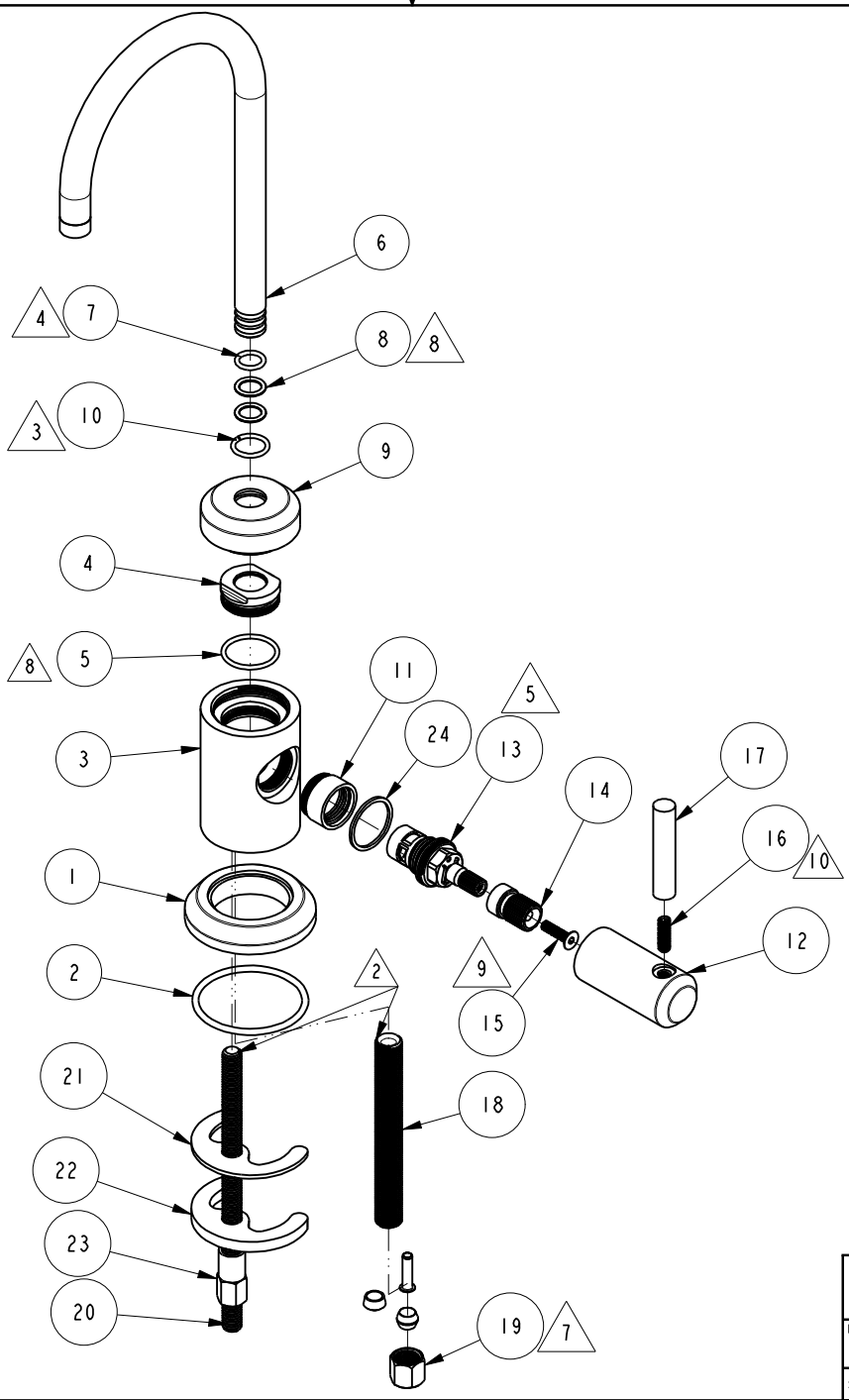

BRASSTECH		2001 E. CARNEGIE AVE. SANTA ANA, CA 92705 (949) 417-5207	
DWG NO.	3200-5623	REV	D
SCALE	.325	REF.	-
SHEET 2		OF 3	

