

NOTES:

1. TO INSPECT ASSEMBLY, FOLLOW FIRST ARTICLE AND IN PROCESS INSPECTION SHEET.

2. REMOVE AND DISCARD THIS PLASTIC NUT.

BILL OF MATERIAL (CURRENT LEVEL)

ITEM	PT/ASSY	DESCRIPTION	TYPE	QTY.
1	5-034	AIR GAP BODY	ASSEMBLY	1
2	1200-5751	METROPOLE AIR GAP CAP	ASSEMBLY	1

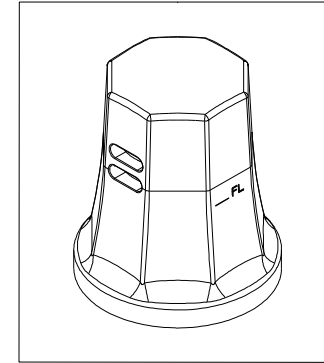
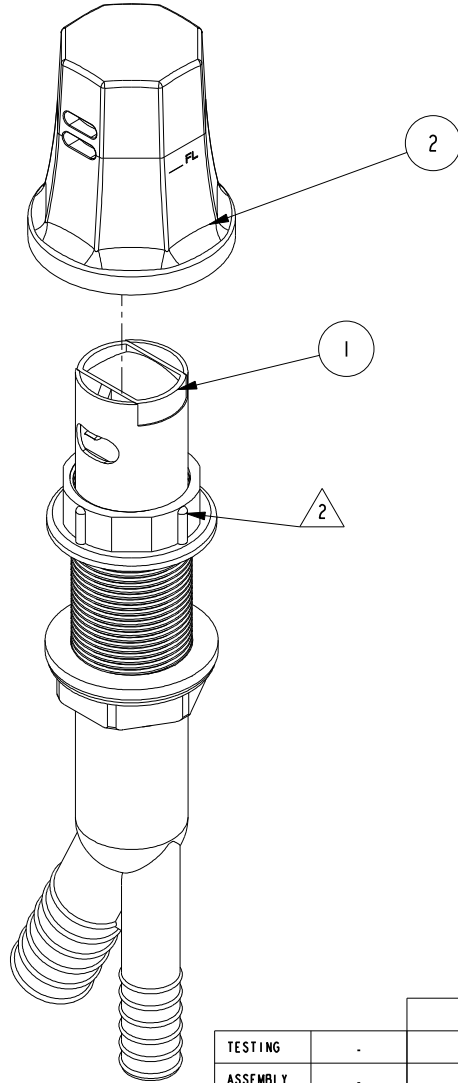

ZONE	REV	DESCRIPTION	DATE	APPROVED
-	A	EN-4300	09/23/21	R. S.
-	-	EN-2184	06/06/12	J. M.

COPYRIGHT 2005 BRASSTECH, INC. THESE DRAWINGS AND THE DESIGNS DEPICTED HEREIN ARE THE PROPRIETARY PROPERTY OF BRASSTECH. ANY USE OR REPRODUCTION IS SUBJECT TO THE EXPRESS APPROVAL OF BRASSTECH. UNAUTHORIZED USE IS STRICTLY PROHIBITED. ALL RIGHTS RESERVED.

TESTING	-	-	-
ASSEMBLY	-	-	-
PLATING	-	-	-
POLISHING	-	NEXT ASSY	USED ON
MACHINING	-	APPLICATION	
TOOLING FIXTURE #	REMOVE ALL BURRS AND SHARP EDGES		

UNITS ARE: INCHES [MM]		
TOLERANCES ARE:		
FRACTIONS	DECIMALS	ANGLES
±1/16"	.X ±.1 [2.5]	±1°
	.XX ±.06 [1.5]	
(X.XXX) DENOTES CRITICAL DIMS.		
ALL THREADS ARE CRITICAL		
DRAWN	R.S.	06/06/12
CHECKED	J.M.	06/06/12
APPROVED	J.M.	06/06/12

BRASSTECH 2001 CARNEGIE AVE.
INCORPORATED SANTA ANA, CA 92705
(949) 417-5207

METROPOLE AIR GAP KIT

DWG NO.	1200-5711	REV	A
SCALE	.500	REF.	-
SHEET	1	OF	2

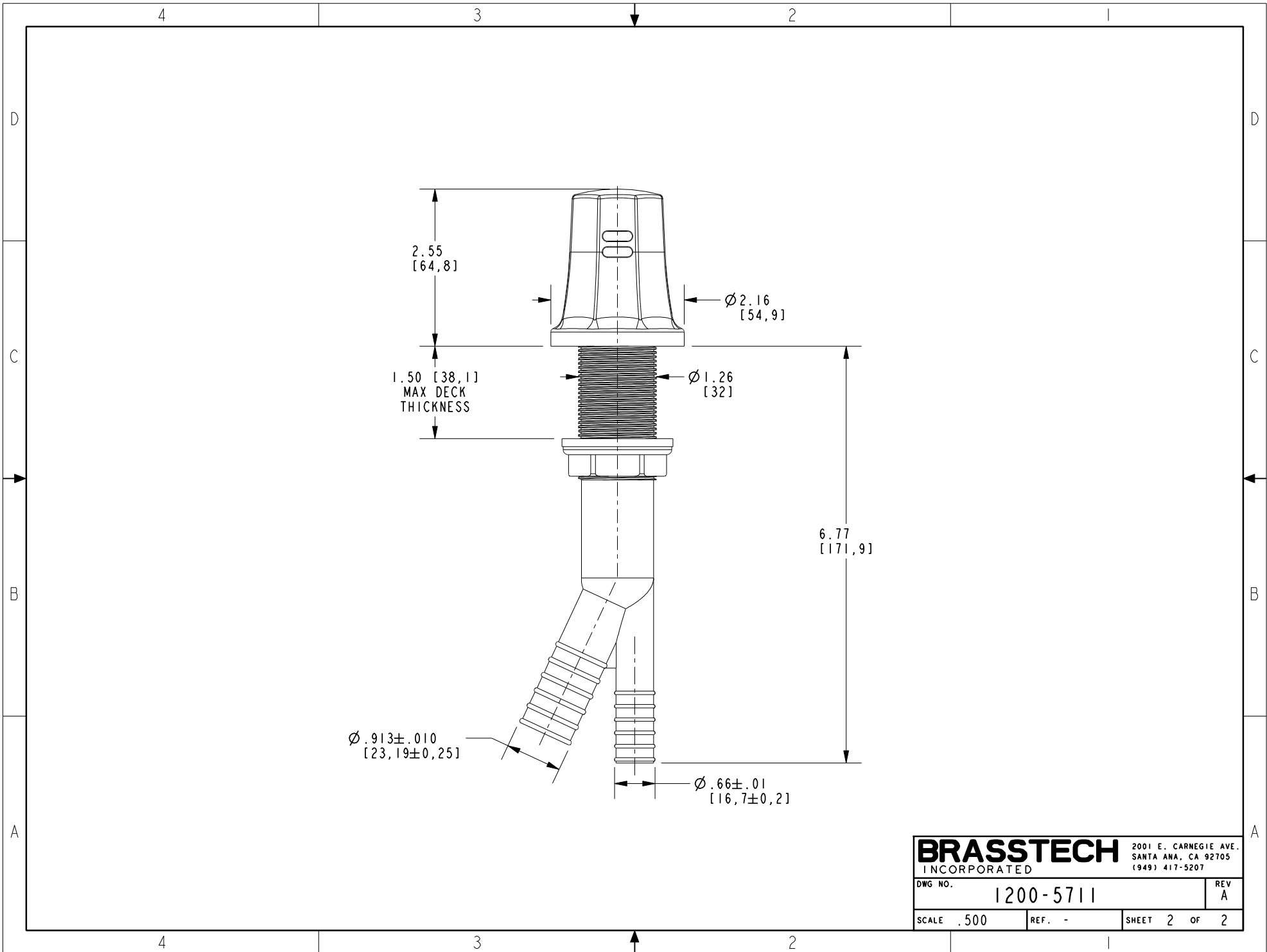

BRASSTECH		2001 E. CARNEGIE AVE. SANTA ANA, CA 92705 (949) 417-5207	
DWG NO.	1200-5711	REV	A
SCALE	.500	REF.	-
		SHEET	2 OF 2