

INSTALLER: LEAVE THIS MANUAL WITH THE APPLIANCE.
CONSUMER: RETAIN THIS MANUAL FOR FUTURE REFERENCE.



INSTALLATION AND OPERATING INSTRUCTIONS

CERTIFIED UNDER CANADIAN AND AMERICAN NATIONAL STANDARDS, CSA 2.33, ANSI Z21.88 FOR VENTED GAS FIREPLACE HEATERS

GDS60N & GS60N
NATURAL GAS

GDS60P & GS60P
PROPANE GAS

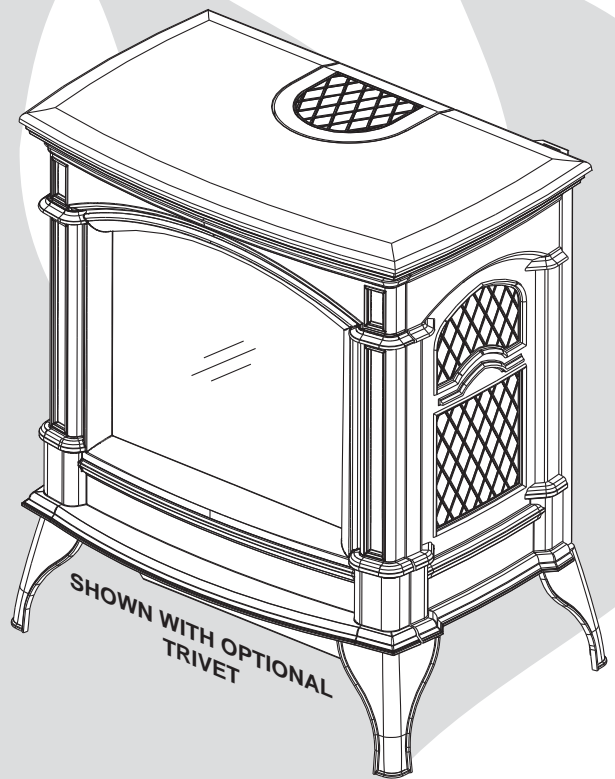

CERTIFIED FOR CANADA AND UNITED STATES USING ANSI/CSA METHODS.

SAFETY INFORMATION

WARNING

If the information in these instructions are not followed exactly, a fire or explosion may result causing property damage, personal injury or loss of life.

- Do not store or use gasoline or other flammable vapors and liquids in the vicinity of this or any other appliance.
- **WHAT TO DO IF YOU SMELL GAS:**
 - Do not try to light any appliance.
 - Do not touch any electrical switch; do not use any phone in your building.
 - Immediately call your gas supplier from a neighbour's phone. Follow the gas supplier's instructions.
 - If you cannot reach your gas supplier, call the fire department.
- Installation and service must be performed by a qualified installer, service agency or the supplier.



APPLY SERIAL NUMBER LABEL FROM CARTON



Wolf Steel Ltd., 24 Napoleon Rd., Barrie, ON, L4M 4Y8 Canada /
103 Miller Drive, Crittenden, Kentucky, USA, 41030

Phone (705)721-1212 • Fax (705)722-6031 • www.napoleonfireplaces.com • ask@napoleonproducts.com

TABLE OF CONTENTS

1.0	INSTALLATION OVERVIEW	3
2.0	INTRODUCTION	4
2.1	DIMENSIONS	5
2.2	GENERAL INSTRUCTIONS	5
2.3	GENERAL INFORMATION	6
2.4	RATING PLATE INFORMATION	7
2.5	SHIPPING BRACKET	8
3.0	VENTING - MODEL GDS60	9
3.1	VENTING LENGTHS AND COMPONENTS	10
3.2	TYPICAL VENT INSTALLATIONS	11
3.3	SPECIAL VENT INSTALLATIONS	13
3.3.1	PERISCOPE TERMINATION	13
3.3.2	CORNER TERMINATION	13
3.4	VENT TERMINAL CLEARANCES	14
3.5	VENTING APPLICATION FLOW CHART	15
3.6	DEFINITIONS	16
3.7	ELBOW VENT LENGTH VALUES	16
3.8	TOP EXIT HORIZONTAL TERMINATION	17
3.9	TOP EXIT HORIZONTAL TERMINATION	18
3.10	REAR EXIT HORIZONTAL TERMINATION	19
3.11	TOP OR REAR EXIT VERTICAL TERMINATION	21
4.0	INSTALLATION PREPARATION - MODEL GDS60	23
4.1	ORIFICE REPLACEMENT	23
4.2	CHANGING A TOP VENT TO A REAR VENT	24
5.0	INSTALLATION	25
5.1	MINIMUM CLEARANCE TO COMBUSTIBLES	25
5.2	WALL AND CEILING PROTECTION	26
5.2.1	HORIZONTAL INSTALLATION	26
5.2.2	VERTICAL INSTALLATION	27
5.2.3	HORIZONTAL AIR TERMINAL INSTALLATION - MODEL GDS60	28
5.2.4	VERTICAL AIR TERMINAL INSTALLATION - MODEL GDS60	29
5.3	APPLIANCE VENT CONNECTION - MODEL GDS60	30
5.4	MOBILE HOME INSTALLATION - MODEL GDS60	30
5.5	GAS INSTALLATION	31
5.6	OPTIONAL WALL SWITCH / THERMOSTAT	31
5.7	B-VENT SPECIFICS - MODEL GS60	32
5.7.1	CHIMNEY INSTALLATION	32
5.7.2	INSTALLING "B" VENT	33
5.7.3	B-VENT	33
5.7.4	COMBUSTION AIR	33
5.7.5	ADDING VENT SECTIONS	34
5.7.6	INSTALLING FLASHING AND STORM COLLAR	35
6.0	FINISHING	36
6.1	FRONT CAST REMOVAL	36
6.2	GLASS DOOR INSTALLATION AND REMOVAL	36
6.3	GLASS / DOOR REPLACEMENT	37
6.4	LOG PLACEMENT	37
6.5	LOGO PLACEMENT	38
6.6	SWITCH AND BRACKET INSTALLATION	39
7.0	OPTIONAL BLOWER INSTALLATION	40
8.0	WIRING DIAGRAM	41
9.0	OPERATION	42
9.1	OPERATING INSTRUCTIONS	42
9.2	OPERATING INSTRUCTIONS - FOR YOUR SAFETY READ BEFORE OPERATING	43
9.3	LIGHTING INSTRUCTIONS	43
9.4	ANTI CONDENSATION SWITCH	43
10.0	ADJUSTMENT	44
10.1	PILOT BURNER ADJUSTMENT	44
10.2	VENTURI ADJUSTMENT	44
10.3	FLAME CHARACTERISTICS	44
10.4	RESTRICTING VERTICAL VENTS - MODEL GDS60	44
11.0	MAINTENANCE	45
11.1	CARE OF GLASS	45
12.0	REPLACEMENTS	46
13.0	TROUBLE SHOOTING	50
14.0	WARRANTY	53
15.0	SERVICE HISTORY	54

NOTE: Changes, other than editorial, are denoted by a vertical line in the margin.

1.0 INSTALLATION OVERVIEW

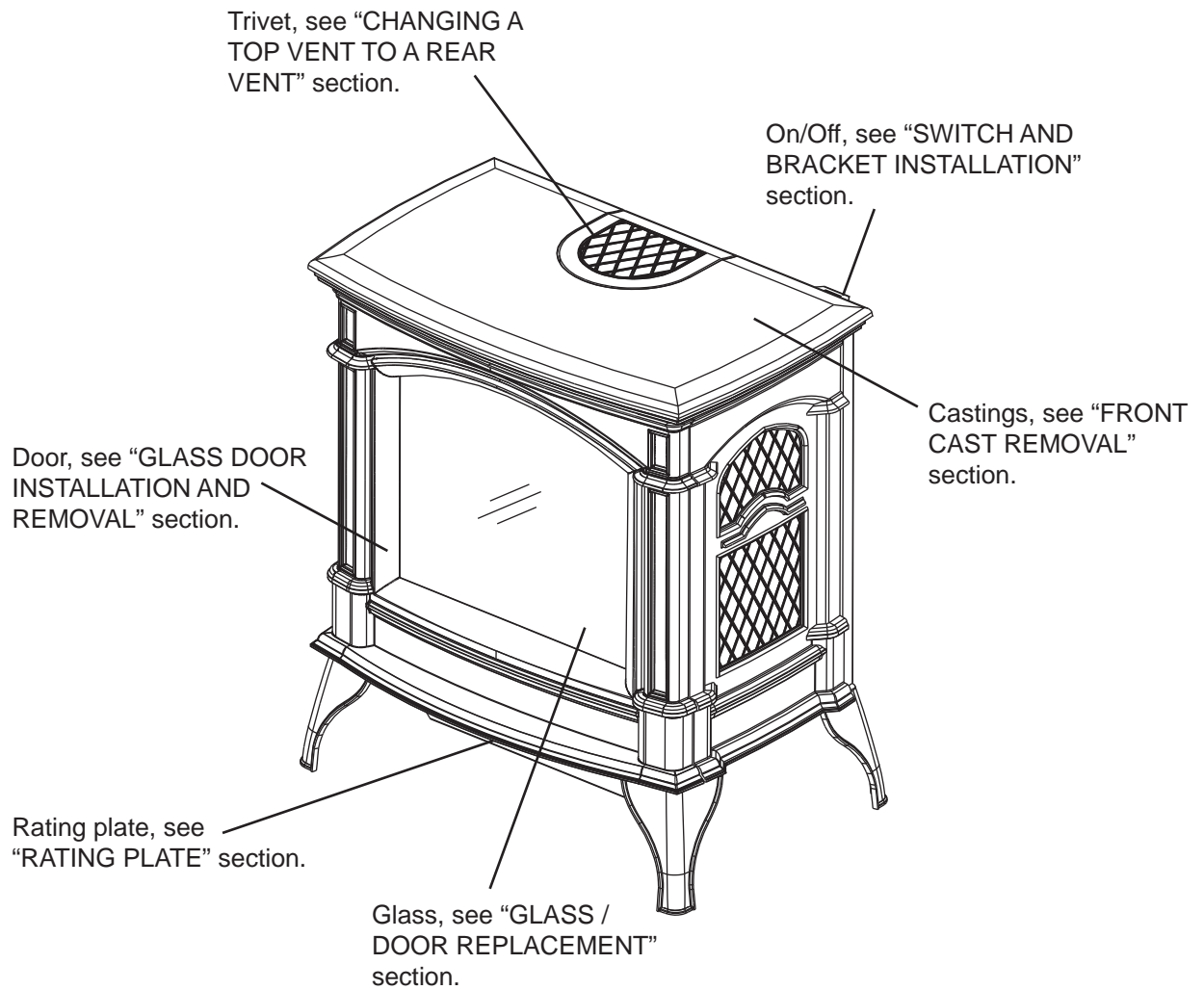

2.0 INTRODUCTION

WARNING

- **THIS APPLIANCE IS HOT WHEN OPERATED AND CAN CAUSE SEVERE BURNS IF CONTACTED.**
- **ANY CHANGES OR ALTERATIONS TO THIS APPLIANCE OR ITS CONTROLS CAN BE DANGEROUS AND IS PROHIBITED.**
- Do not operate appliance before reading and understanding operating instructions. Failure to operate appliance according to operating instructions could cause fire or injury.
- Risk of fire or asphyxiation do not operate appliance with fixed glass removed.
- Do not connect 110 volts to the control valve.
- Risk of burns. The appliance should be turned off and cooled before servicing.
- Do not install damaged, incomplete or substitute components.
- Risk of cuts and abrasions. Wear protective gloves and safety glasses during installation. Sheet metal edges may be sharp.
- Do not burn wood or other materials in this appliance.
- Young children should be carefully supervised when they are in the same room as the appliance. Toddlers, young children and others may be susceptible to accidental contact burns. A physical barrier is recommended if there are at risk individuals in the house. To restrict access to an appliance or stove, install an adjustable safety gate to keep toddlers, young children and other at risk individuals out of the room and away from hot surfaces.
- Clothing or other flammable material should not be placed on or near the appliance.
- Due to high temperatures, the appliance should be located out of traffic and away from furniture and draperies.
- Ensure you have incorporated adequate safety measure to protect infants/toddlers from touching hot surfaces.
- Even after the appliance is out, the glass and/or screen will remain hot for an extended period of time.
- Check with your local hearth specialty dealer for safety screens and hearth guards to protect children from hot surfaces. These screens and guards must be fastened to the floor.
- Any safety screen or guard removed for servicing must be replaced prior to operating the appliance.
- The appliance is a vented gas-fired appliance. Do not burn wood or other materials in the appliance
- It is imperative that the control compartments, burners and circulating blower and its passageway in the appliance and venting system are kept clean. The appliance and its venting system should be inspected before use and at least annually by a qualified service person. More frequent cleaning may be required due to excessive lint from carpeting, bedding material, etc. The appliance area must be kept clear and free from combustible materials, gasoline and other flammable vapors and liquids.
- Under no circumstances should this appliance be modified.
- This appliance must not be connected to a chimney flue pipe serving a separate solid fuel burning appliance.
- Do not use this appliance if any part has been under water. Immediately call a qualified service technician to inspect the appliance and to replace any part of the control system and any gas control which has been under water.
- Do not operate the appliance with the glass door removed, cracked or broken. Replacement of the glass should be done by a licensed or qualified service person.
- Do not strike or slam shut the appliance glass door.
- When equipped with pressure relief doors, they must be kept closed while the appliance is operating to prevent exhaust fumes containing carbon monoxide, from entering into the home. Temperatures of the exhaust escaping through these openings can also cause the surrounding combustible materials to overheat and catch fire.
- Only doors / optional fronts certified with the unit are to be installed on the appliance.
- Keep the packaging material out of reach of children and dispose of the material in a safe manner. As with all plastic bags, these are not toys and should be kept away from children and infants.
- As with any combustion appliance, we recommend having your appliance regularly inspected and serviced as well as having a Carbon Monoxide Detector installed in the same area to defend you and your family against Carbon Monoxide.
- Ensure clearances to combustibles are maintained when building a mantel or shelves above the appliance. Elevated temperatures on the wall or in the air above the appliance can cause melting, discolouration or damage of decorations, a T.V. or other electronic components.

3.2A

2.1 DIMENSIONS

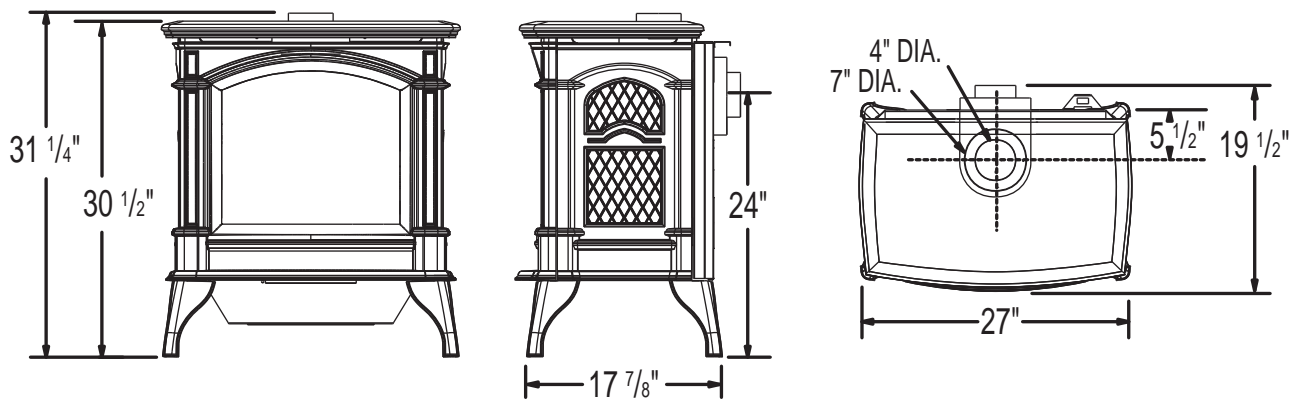

2.2 GENERAL INSTRUCTIONS

! WARNING
ALWAYS LIGHT THE PILOT WHETHER FOR THE FIRST TIME OR IF THE GAS SUPPLY HAS RAN OUT, WITH THE GLASS DOOR OPENED OR REMOVED.
PROVIDE ADEQUATE CLEARANCE FOR SERVICING AND OPERATING THE APPLIANCE.
PROVIDE ADEQUATE VENTILATION.
NEVER OBSTRUCT THE FRONT OPENING OF THE APPLIANCE.
OBJECTS PLACED IN FRONT OF THE APPLIANCE MUST BE KEPT A MINIMUM OF 48" FROM THE FRONT FACE OF THE UNIT.
SURFACES AROUND AND ESPECIALLY ABOVE THE APPLIANCE CAN BECOME HOT. AVOID CONTACT WHEN THE APPLIANCE IS OPERATING.
FIRE RISK. EXPLOSION HAZARD.
HIGH PRESSURE WILL DAMAGE VALVE. DISCONNECT GAS SUPPLY PIPING BEFORE PRESSURE TESTING GAS LINE AT TEST PRESSURES ABOVE 1/2 PSIG. CLOSE THE MANUAL SHUT-OFF VALVE BEFORE PRESSURE TESTING GAS LINE AT TEST PRESSURES EQUAL TO OR LESS THAN 1/2 PSIG.
USE ONLY WOLF STEEL APPROVED OPTIONAL ACCESSORIES AND REPLACEMENT PARTS WITH THIS APPLIANCE. USING NON-LISTED ACCESSORIES (BLOWERS, DOORS, LOUVRES, TRIMS, GAS COMPONENTS, VENTING COMPONENTS, ETC.) COULD RESULT IN A SAFETY HAZARD AND WILL VOID THE WARRANTY AND CERTIFICATION.

THIS GAS APPLIANCE SHOULD BE INSTALLED AND SERVICED BY A QUALIFIED INSTALLER to conform with local codes. Installation practices vary from region to region and it is important to know the specifics that apply to your area, for example in Massachusetts State:

- This product must be installed by a licensed plumber or gas fitter when installed within the commonwealth of Massachusetts.
- The appliance damper must be removed or welded in the open position prior to installation of a appliance insert or gas log.
- The appliance off valve must be a "T" handle gas cock.
- The flexible connector must not be longer than 36 inches.
- A Carbon Monoxide detector is required in all rooms containing gas fired appliances.
- The appliance is not approved for installation in a bedroom or bathroom unless the unit is a direct vent sealed combustion product.

The installation must conform with local codes or, in absence of local codes, the National Gas and Propane Installation Code CSA B149.1 in Canada, or the National Fuel Gas Code, ANSI Z223.1 / NFPA 54 in the United States. Suitable for mobile home installation if installed in accordance with the current standard CAN/CSA Z240MH Series, for gas equipped mobile homes, in Canada or ANSI Z223.1 and NFPA 54 in the United States.

**NATIONAL
FIREPLACE
INSTITUTE**



CERTIFIED

www.nficertified.org

We suggest that our gas hearth products be installed and serviced by professionals who are certified in the U.S. by the National Fireplace Institute® (NFI) as NFI Gas Specialists

As long as the required clearance to combustibles is maintained, the most desirable and beneficial location for an appliance is in the center of a building, thereby allowing the most efficient use of the heat created. The location of windows, doors and the traffic flow in the room where the appliance is to be located should be considered. If possible, you should choose a location where the vent will pass through the house without cutting a floor or roof joist.

If the appliance is installed directly on carpeting, vinyl tile or other combustible material other than wood flooring, the appliance shall be installed on a metal or wood panel extending the full width and depth.

Some appliances have optional fans or blowers. If an optional fan or blower is installed, the junction box must be electrically connected and grounded in accordance with local codes, use the current CSA C22.1 Canadian Electrical Code in Canada or the ANSI/NFPA 70 National Electrical code in the United States.

4.1A

When the appliance is installed directly on carpeting, vinyl tile or other combustible material other than wood flooring, the appliance shall be installed on a metal or wood panel extending the full width and depth.

The appliance, when installed with a blower, must be electrically connected and grounded in accordance with local codes. In the absence of local codes, use the current CSA C22.1 Canadian Electrical Code in Canada or the ANSI/NFPA 70-1996 National Electrical Code in the United States. The blower power cord must be connected into a properly grounded receptacle. The grounding prong must not be removed from the cord plug.

2.3 GENERAL INFORMATION

FOR YOUR SATISFACTION, THIS APPLIANCE HAS BEEN TEST-FIRED TO ASSURE ITS OPERATION AND QUALITY!

	GDS60		GS60	
	NG	LP	NG	LP
Altitude (FT)	0-4,500	0-4500	0-4500	0-4500
Max. Input (BTU/HR)	35,000 (Top vent) 21,000 (Rear vent)	31,500 (Top vent) 21,000 (Rear vent)	35,000	31,500
Max. Output (BTU/HR)	27,300	24,570	27,300	24,570
Max. Steady State Efficiency (w/the fan on)	78%	78%	78%	78%
Max. A.F.U.E.	72%	71%	72%	71%
Min. Inlet Gas Supply Pressure	4.5" Water Column	11" Water Column	4.5" Water Column	11" Water Column
Max. Inlet Gas Supply Pressure	7" Water Column	13" Water Column	7" Water Column	13" Water Column
Manifold Pressure (Under Flow Conditions)	3.5" Water Column	10" Water Column	3.5" Water Column	10" Water Column

When the appliance is installed at elevations above 4,500ft, and in the absence of specific recommendations from the local authority having jurisdiction, the certified high altitude input rating shall be reduced at the rate of 4% for each additional 1,000ft.

Change in flame appearance from "HI" to "LO" is more evident in natural gas than in propane.

Expansion / contraction noises during heating up and cooling down cycles are normal and to be expected.

This appliance is only for use with the type of gas indicated on the rating plate. This appliance is not convertible for use with other gases, unless a certified kit is used.

GDS60 - This appliance is not approved for closet or recessed installations. It is approved for bathroom, bedroom and bed-sitting room installations. This appliance may be installed in an aftermarket permanently located, manufactured (mobile) home, where not prohibited by local codes. **(Rear vent)** This application requires changing the main burner orifice.

GS60 - This appliance is approved for bedroom and bed-sitting room installations.

2.4 RATING PLATE INFORMATION

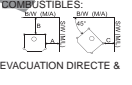
		CERTIFIED UNDER: ANSI Z21.88-2009 • CSA 2.33-2009, VENTED GAS FIREPLACE HEATER AS A DIRECT VENT AND CSA2.226-2009/ANSI Z21.506-2009 VENTED GAS FIREPLACE AS A B-VENT. HOMOLOGUE SELON LES NORMES: CSA 2.33-2009, ANSI Z21.88-2009 FOYER DE CHAUFFAGE AU GAZ AVEC EVACUATION EN TANT QU'UNE EVACUATION DIRECTE ET CSA2.226-2009/ANSI Z21.506-2009 FOYER AU GAZ AVEC EVACUATION EN TANT QU'UN EVENT "B".		MODEL CDVS600/GDS60 APPROVED FOR BEDROOM, BATHROOM & BEDSITTING ROOM INSTALLATION. SUITABLE FOR MOBILE HOME INSTALLATION IF INSTALLED IN ACCORDANCE WITH THE CURRENT STANDARD CAN/CSA Z240MH SERIES GAS EQUIPPED MOBILE HOMES. IN CANADA OR IN THE UNITED STATES THE MANUFACTURED HOME CONSTRUCTION AND SAFETY STANDARD, TITLE 24 CFR, PART 3280. WHEN THIS US STANDARD IS NOT APPLICABLE USE THE STANDARD FOR FIRE SAFETY CRITERIA FOR MANUFACTURED HOME INSTALLATIONS, SITES AND COMMUNITIES, ANSINFA 501A. HOMOLOGUE POUR INSTALLATION DANS UNE CHAMBRE A COUCHER, UNE SALLE DE BAIN ET UN STUDIO. APPROPRIE POUR INSTALLATION DANS UNE MAISON MOBILE SI SON INSTALLATION CONFORME AUX EXIGENCES DE LA NORME CAN/CSA Z240MH SERIE DE MAISONS MOBILES EQUIPEES AU GAZ. EN VIGUEUR AU CANADA OU AUX ETATS-UNIS DE LA NORME DE SECURITE ET DE CONSTRUCTION DE MAISONS MANUFACTUREES, TITRE 24 CFR, SECTION 3280. DANS LE CAS OU CETTE NORME D'ETATS-UNIS NE PEUT ETRE APPLIQUEE, SE REFERER A LA NORME RELATIVE AU CRITERE DE MESURES DE SECURITE CONTRE L'INCENDIE POUR LES INSTALLATIONS DANS LES MAISONS MANUFACTUREES, LES SITES ET LES COMMUNAUTES, ANSINFA 501A.	
NOT FOR USE WITH SOLID FUEL UN COMBUSTIBLE SOLIDE NE DOIT PAS ETRE UTILISE AVEC CET APPAREIL		MODEL PROPANE/PROPANE MODELE		MODEL GDS600/GDS60 APPROVED FOR BEDROOM, BATHROOM & BEDSITTING ROOM INSTALLATION. SUITABLE FOR MOBILE HOME INSTALLATION IF INSTALLED IN ACCORDANCE WITH THE CURRENT STANDARD CAN/CSA Z240MH SERIES GAS EQUIPPED MOBILE HOMES. IN CANADA OR IN THE UNITED STATES THE MANUFACTURED HOME CONSTRUCTION AND SAFETY STANDARD, TITLE 24 CFR, PART 3280. WHEN THIS US STANDARD IS NOT APPLICABLE USE THE STANDARD FOR FIRE SAFETY CRITERIA FOR MANUFACTURED HOME INSTALLATIONS, SITES AND COMMUNITIES, ANSINFA 501A. HOMOLOGUE POUR INSTALLATION DANS UNE CHAMBRE A COUCHER, UNE SALLE DE BAIN ET UN STUDIO. APPROPRIE POUR INSTALLATION DANS UNE MAISON MOBILE SI SON INSTALLATION CONFORME AUX EXIGENCES DE LA NORME CAN/CSA Z240MH SERIE DE MAISONS MOBILES EQUIPEES AU GAZ. EN VIGUEUR AU CANADA OU AUX ETATS-UNIS DE LA NORME DE SECURITE ET DE CONSTRUCTION DE MAISONS MANUFACTUREES, TITRE 24 CFR, SECTION 3280. DANS LE CAS OU CETTE NORME D'ETATS-UNIS NE PEUT ETRE APPLIQUEE, SE REFERER A LA NORME RELATIVE AU CRITERE DE MESURES DE SECURITE CONTRE L'INCENDIE POUR LES INSTALLATIONS DANS LES MAISONS MANUFACTUREES, LES SITES ET LES COMMUNAUTES, ANSINFA 501A.	
MODEL NATURAL GAS/GAZ NATURAL		MODEL PROPANE/PROPANE MODELE		MODEL GDS600/GDS60 APPROVED FOR BEDROOM, BATHROOM & BEDSITTING ROOM INSTALLATION. SUITABLE FOR MOBILE HOME INSTALLATION IF INSTALLED IN ACCORDANCE WITH THE CURRENT STANDARD CAN/CSA Z240MH SERIES GAS EQUIPPED MOBILE HOMES. IN CANADA OR IN THE UNITED STATES THE MANUFACTURED HOME CONSTRUCTION AND SAFETY STANDARD, TITLE 24 CFR, PART 3280. WHEN THIS US STANDARD IS NOT APPLICABLE USE THE STANDARD FOR FIRE SAFETY CRITERIA FOR MANUFACTURED HOME INSTALLATIONS, SITES AND COMMUNITIES, ANSINFA 501A. HOMOLOGUE POUR INSTALLATION DANS UNE CHAMBRE A COUCHER, UNE SALLE DE BAIN ET UN STUDIO. APPROPRIE POUR INSTALLATION DANS UNE MAISON MOBILE SI SON INSTALLATION CONFORME AUX EXIGENCES DE LA NORME CAN/CSA Z240MH SERIE DE MAISONS MOBILES EQUIPEES AU GAZ. EN VIGUEUR AU CANADA OU AUX ETATS-UNIS DE LA NORME DE SECURITE ET DE CONSTRUCTION DE MAISONS MANUFACTUREES, TITRE 24 CFR, SECTION 3280. DANS LE CAS OU CETTE NORME D'ETATS-UNIS NE PEUT ETRE APPLIQUEE, SE REFERER A LA NORME RELATIVE AU CRITERE DE MESURES DE SECURITE CONTRE L'INCENDIE POUR LES INSTALLATIONS DANS LES MAISONS MANUFACTUREES, LES SITES ET LES COMMUNAUTES, ANSINFA 501A.	
DIRECT VENT		B-VENT		DIRECT VENT	
■ GDS60N ■ CDVS600N		■ GS60N ■ CS600N		■ GDS60P ■ CDVS600P	
TOP VENT REAR VENT		B-VENT		REAR VENT TOP VENT	
■ ■ 0-4500 0-4500 35,000 *21,000 21,000 *12,000 24,500 *14,700		0-4500 ALTITUDE (FT/PI) ELEVATION 31,500 INPUT (BTU/H) ALIMENTATION 22,000 REDUCED INPUT (BTU/H) ALIMENTATION REDUITE OUTPUT (BTU/H) RENDEMENT		0-4500 31,500 22,000 22,000	
*WHEN VENTING OFF THE REAR OF THE UNIT AND TERMINATING HORIZONTALLY		*WHEN VENTING OFF THE REAR OF THE UNIT AND TERMINATING HORIZONTALLY		*WHEN VENTING OFF THE REAR OF THE UNIT AND TERMINATING HORIZONTALLY	
MANIFOLD PRESSURE: 3.5 INCHES W.C. (NG) / 10 INCHES W.C. (LP) PRESSION AU COLLECTEUR: 3.5" (GN) / 10" (PG) D'UNE COLONNE D'EAU MIN SUPPLY PRESSURE: 4.5" W.C. (NG) / 11" (LP) PRESSION D'ALIMENTATION MIN: 4.5" (GN) / 11" (PG) D'UNE COLONNE D'EAU MAX. SUPPLY PRESSURE: 7" W.C. (NG) / 13" W.C. (LP) PRESSION D'ALIMENTATION MAX: 7" (GN) / 13" (PG) D'UNE COLONNE D'EAU FOR USE WITH GLASS DOORS CERTIFIED WITH THIS UNIT ONLY. UTILISER AVEC LES PORTES VITREES HOMOLOGUEES SEULEMENT AVEC CETTE UNITE. WARNING: DO NOT ADD ANY MATERIAL TO THE APPLIANCE, WHICH WILL COME IN CONTACT WITH THE FLAMES, OTHER THAN THAT SUPPLIED BY THE MANUFACTURER WITH THE APPLIANCE.		OPTIONAL BLOWER KIT / ENSEMBLE DE VENTILATEUR FAIBLESURTIT: GS60KIT AVERTISSEMENT: N'AJOUTEZ PAS A CET APPAREIL AUCUN MATERIAU DEVANT ENTRER EN CONTACT AVEC LES FLAMMES AUTRE QUE CELUI QUI EST FOURNI AVEC CET APPAREIL PAR LE FABRICATEUR. MINIMUM CLEARANCE TO COMBUSTIBLE MATERIAL / DEGAGEMENTS MINIMAUX DES MATERIAUX COMBUSTIBLES: A 6" B 6" C 2" 20" TO CEILING FROM STOVE TOP 11" TO DIRECT VENT AND B-VENT / L'EVACUATION DIRECTE & L'EVACUATION "B" 6" TO C-VENT / A L'EVACUATION C 20" ENTRE LE DESSUS DU FOYER ET LE PLAFOND ELECTRICAL RATING/CLASS: 115V 1.5AMP 60HZ		THE APPLIANCE MUST BE VENTED USING THE APPROPRIATE NAPOLEON VENT KITS. SEE OWNERS INSTALLATION MANUAL FOR VENTING SPECIFICS. PROPER REINSTALLATION AND RESEALING IS NECESSARY AFTER SERVICING THE VENT-AIR INTAKE SYSTEM. L'APPAREIL DOIT EVACUER SES GAZ EN UTILISANT L'ENSEMBLE D'EVACUATION PROPRE A NAPOLEON. REFERER AU MANUEL D'INSTALLATION DE PROPRIETAIRE POUR L'EVACUATION PRECISE. IL EST IMPORTANT DE BIEN REINSTALLER ET RECELLER L'EVENT APRES AVOIR ASSURE LE MAINTIEN DU SYSTEME DE PRISE D'AIR.	
MODEL CS600/GS60 APPROVED FOR BEDROOM, & BEDSITTING ROOM INSTALLATION. HOMOLOGUE POUR INSTALLATION DANS UNE CHAMBRE A COUCHER, & UN STUDIO. THIS APPLIANCE MUST BE INSTALLED USING AN ADAPTER KIT GS-150KT. CET APPAREIL DOIT ETRE INSTALLE EN UTILISANT UN ENSEMBLE D'ADAPTEUR GS-150KT.				SERIAL NUMBER GDS60 NO. DE SERIE WOLF STEEL LTD. 24 NAPOLEON ROAD, BARRIE, ON, L4M 4Y4 CANADA W385-0459 / B	

INSTALLER: It is your responsibility to check off the appropriate box on the rating plate according to the model, venting and gas type of the unit.

For rating plate location, see "INSTALLATION OVERVIEW" section.

This illustration is for reference only. Refer to the rating plate on the appliance for accurate information.

! WARNING

THE TOP CASTING IS NOT FASTENED TO THE STOVE ASSEMBLY. IT SIMPLY SITS ON THE STOVE AS A LID. FOR SHIPPING PURPOSES IT IS HELD IN PLACE BY PLASTIC STRAPPING. ONCE THE STRAPPING IS CUT, THE TOP SHOULD BE LIFTED OFF CAREFULLY AND STORED IN A SAFE PLACE TO AVOID DAMAGE WHILE COMPLETING THE INSTALLATION OF THE STOVE. TO AVOID THE APPLIANCE BEING DAMAGED DURING SHIPPING, A SHIPPING BRACKET HAS BEEN USED AND MUST BE UNBOLTED BEFORE THE APPLIANCE CAN BE INSTALLED.

SHIPPING BRACKET REMOVAL

- A. Remove the four screws holding the shipping bracket to the bottom of the appliance.
- B. Lift the appliance off the skid and set on a flat surface.
- C. Discard the screws, brackets and skid.

GLASS DOOR REMOVAL

- A. Lift the top casting off.
- B. Open the valve control cover. Pull the latch handles forward to release. The door may now be safely removed by swinging the bottom out and lifting it off.

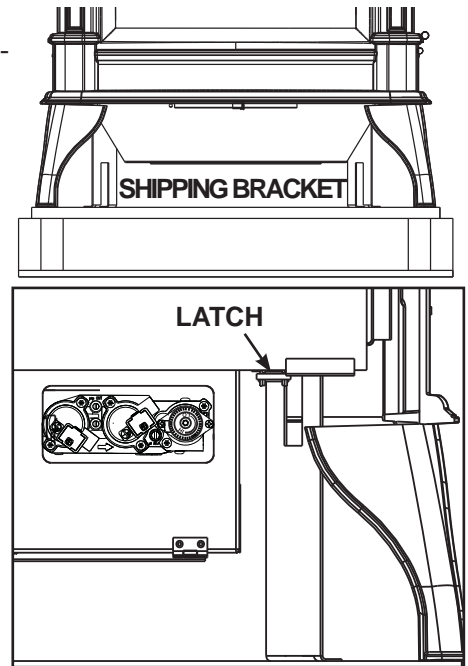

3.0 VENTING - MODEL GDS60

WARNING

RISK OF FIRE, MAINTAIN SPECIFIED AIR SPACE CLEARANCES TO VENT PIPE AND APPLIANCE.

IF VENTING IS INCLUDED WITH SPACERS THE VENT SYSTEM MUST BE SUPPORTED EVERY 3 FEET FOR BOTH VERTICAL AND HORIZONTAL RUNS. USE SUPPORTS OR EQUIVALENT NON-COMBUSTIBLE STRAPPING TO MAINTAIN THE REQUIRED CLEARANCE FROM COMBUSTIBLES. USE WOLF STEEL LTD. SUPPORT RING ASSEMBLY W010-0370 OR EQUIVALENT NON-COMBUSTIBLE STRAPPING TO MAINTAIN THE MINIMUM CLEARANCE TO COMBUSTIBLES FOR BOTH VERTICAL AND HORIZONTAL RUNS. SPACERS ARE ATTACHED TO THE INNER PIPE AT PREDETERMINED INTERVALS TO MAINTAIN AN EVEN AIR GAP TO THE OUTER PIPE. THIS GAP IS REQUIRED FOR SAFE OPERATION. A SPACER IS REQUIRED AT THE START, MIDDLE AND END OF EACH ELBOW TO ENSURE THIS GAP IS MAINTAINED. THESE SPACERS MUST NOT BE REMOVED.

**THIS APPLIANCE USES A 4" EXHAUST / 7" AIR INTAKE VENT PIPE SYSTEM.
Refer to the section applicable to your installation.**

For safe and proper operation of the appliance follow the venting instruction exactly. Deviation from the minimum vertical vent length can create difficulty in burner start-up and/or carboning. Under extreme vent configurations, allow several minutes (5-15) for the flame to stabilize after ignition. Vent lengths that pass through unheated spaces (attics, garages, crawl spaces) should be insulated with the insulation wrapped in a protective sleeve to minimize condensation. Provide a means for visually checking the vent connection to the appliance after the appliance is installed. Use a firestop, vent pipe shield or attic insulation shield when penetrating interior walls, floor or ceiling.

NOTE: If for any reason the vent air intake system is disassembled; reinstall per the instructions provided for the initial installation.

7.1

A terminal shall not terminate directly above a sidewalk or paved driveway which is located between two single family dwellings and serves both dwellings. Local codes or regulations may require different clearances.

Do not allow the inside liner to bunch up on horizontal or vertical runs and elbows. Keep it pulled tight. A 1-1/4" air gap all around between the inner liner and outer appliance pipe is required for safe operation. Use a firestop when penetrating interior walls, floor or ceiling.

Use only Wolf Steel, Simpson Dura-Vent, Selkirk Direct Temp or American Metal Amerivent venting components. Minimum and maximum vent lengths, for both horizontal and vertical installations, and air terminal locations for either systems are set out in this manual and must be adhered to.

3.1 VENTING LENGTHS AND COMPONENTS

Use only Wolf Steel, Simpson Dura-Vent, Selkirk Direct Temp, American Metal Amerivent or Metal-Fab venting components. Minimum and maximum vent lengths, for both horizontal and vertical installations, and air terminal locations for either system are set out in this manual and must be adhered to. For Simpson Dura-Vent, Selkirk Direct Temp, American Metal Amerivent and Metal-Fab follow the installation procedure provided with the venting components.

A starter adaptor must be used with the following vent systems and may be purchased from the corresponding supplier:

PART	4"/7"	SUPPLIER	WEBSITE
Duravent	GDS924N	Wolf Steel	www.duravent.com
Amerivent	4DSC-N2	American Metal	www.americanmetalproducts.com
Direct Temp	4DT-AAN	Selkirk	www.selkirkcorp.com
SuperSeal	4DNA	Metal-Fab	www.mtlfab.com

*** For Simpson Dura-Vent, Selkirk Direct Temp, American Metal Amerivent and Metal-Fab follow the installation procedure found on the website for your venting supplier.**

For vent systems that provide seals on the inner exhaust flue, only the outer air intake joints must be sealed using a red high temperature silicone (RTV). This same sealant may be used on both the inner exhaust and outer intake vent pipe joints of all other approved vent systems except for the exhaust vent pipe connection to the appliance flue collar which must be sealed using the black high temperature sealant Mill Pac.

When using Wolf Steel venting components, use only approved Wolf Steel termination kits: wall terminal kit **GD175** (7/12' of venting included), or 1/12 to 7/12 pitch roof terminal kit **GD110**, 8/12 to 12/12 roof terminal kit **GD111**, flat roof terminal kit **GD112** or periscope kit **GD180** (for wall penetration below grade) in conjunction with the appropriate venting components.

For optimum flame appearance and appliance operation, keep the vent length and number of elbows to a minimum. It is recommended that all horizontal runs have a minimum 1/4" rise per foot. The air terminal must remain unobstructed at all times. Examine the air terminal at least once a year to verify that it is unobstructed and undamaged. Rigid and flexible venting systems must not be combined. Different venting manufacturers components must not be combined.

These vent kits allow for either horizontal or vertical venting of the appliance. The maximum allowable horizontal run is 20 feet. The maximum allowable vertical vent length is 40 feet. The maximum number of vent connections is two horizontally or three vertically (excluding the appliance and the air terminal connections) when using flexible venting.

Deviation from the minimum vertical vent length can create difficulty in burner start-up and/or carboning. Use an adjustable pipe as the final length of rigid piping to the stove for ease of installation.

3.2 TYPICAL VENT INSTALLATIONS

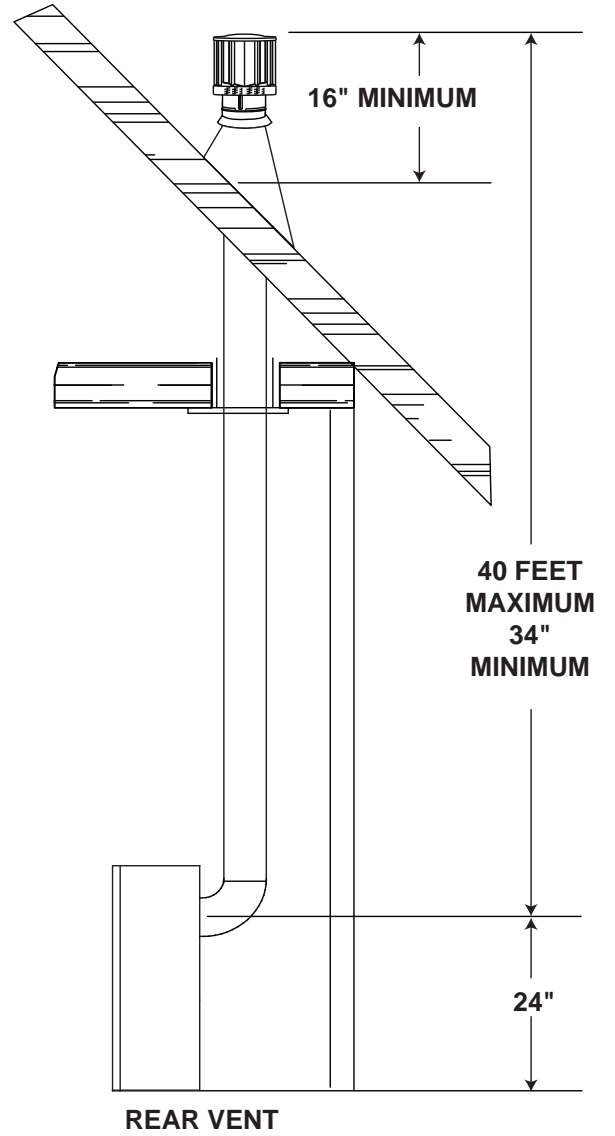
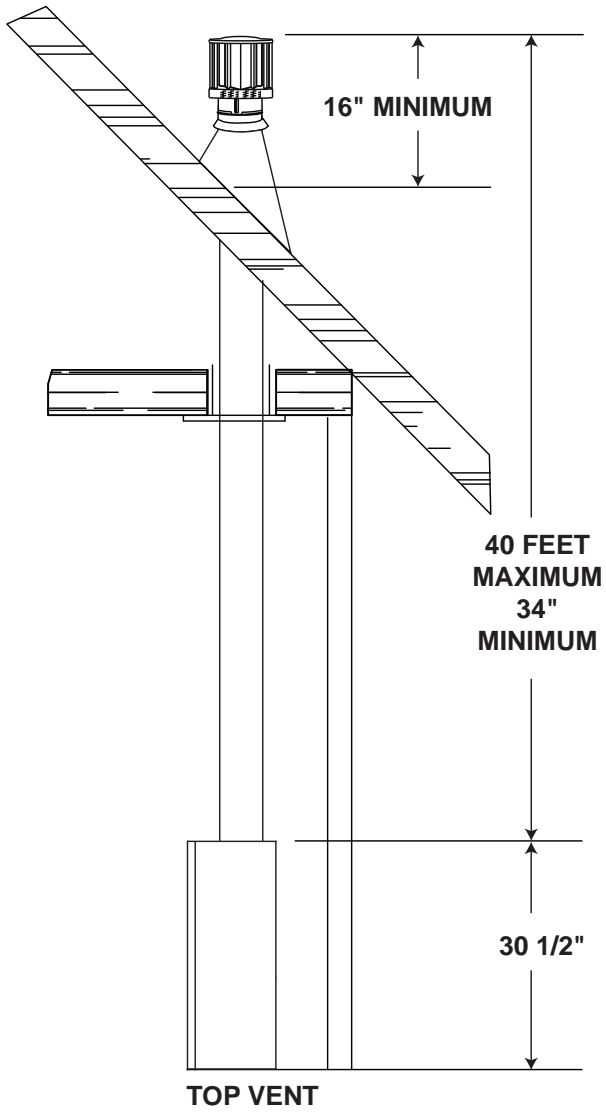

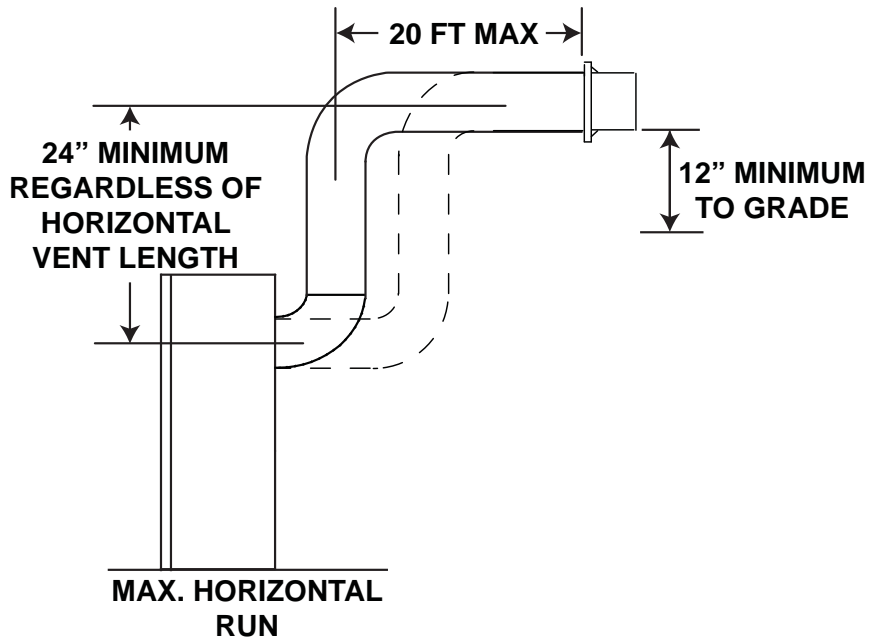
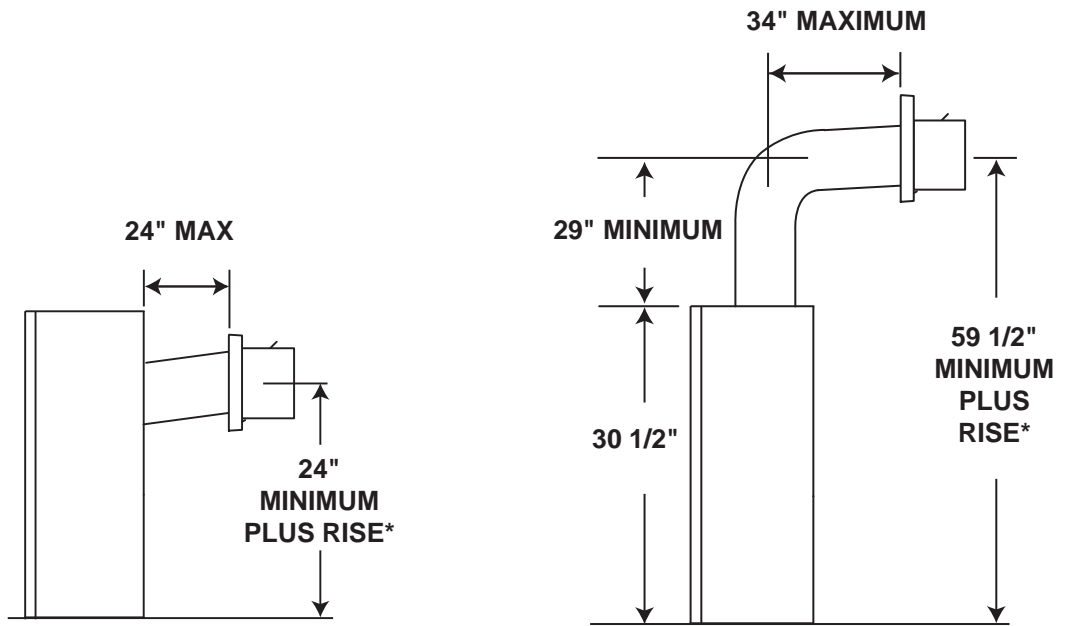

* See "VENTING" section.

3.3 SPECIAL VENT INSTALLATIONS

3.3.1 PERISCOPE TERMINATION

Use the periscope kit to locate the air termination above grade. The periscope must be installed so that when final grading is completed, the bottom air slot is located a minimum 12" above grade. The maximum allowable vent length is 10'.

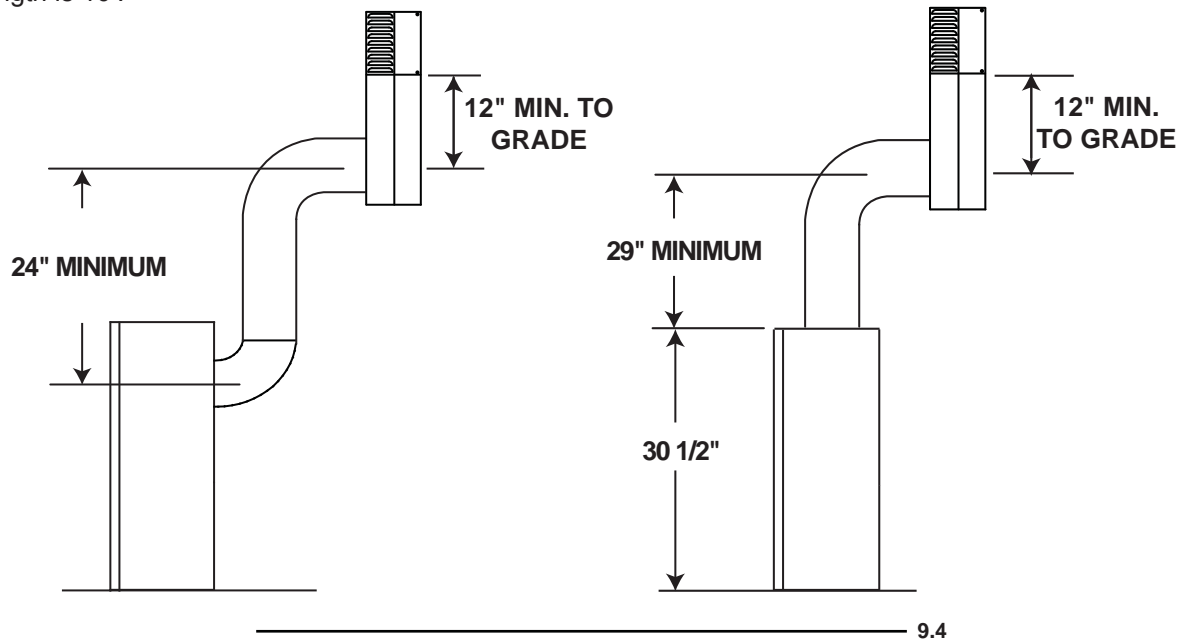

3.3.2 CORNER TERMINATION

The maximum vent length for a corner installation is 24".

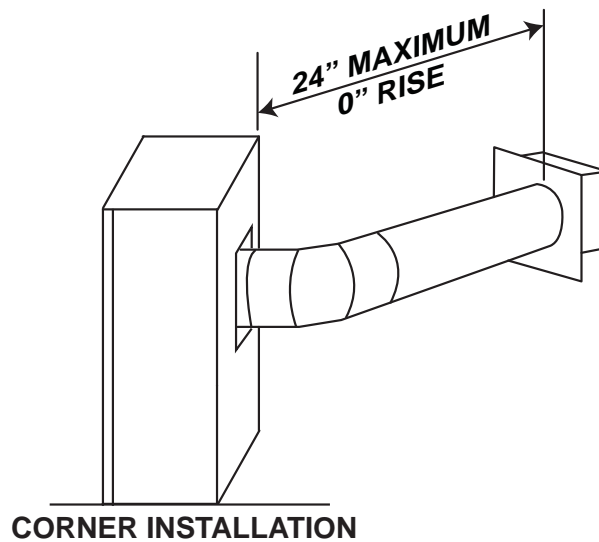

3.4 VENT TERMINAL CLEARANCES

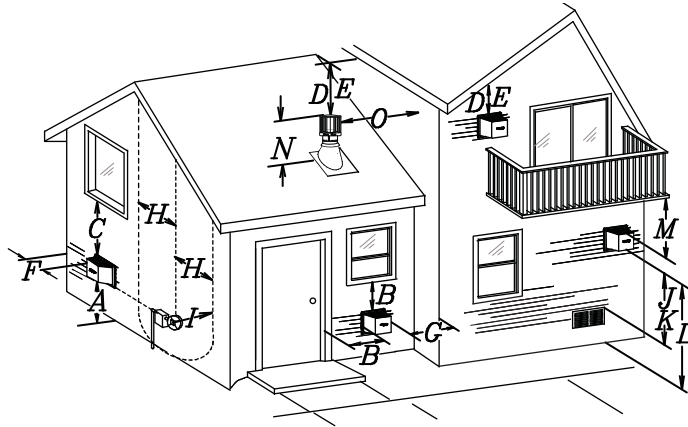

COVERED BALCONY APPLICATIONS ††*

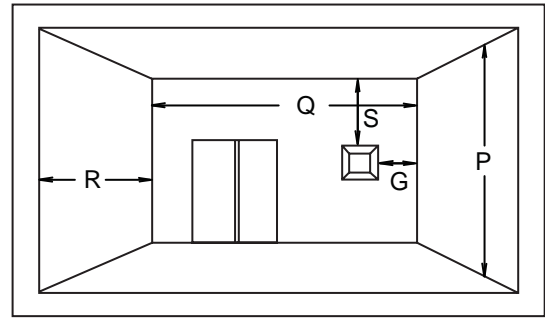

Q_{MIN}	= 3 feet
R_{MAX}	= 2 x Q_{ACTUAL}
R_{MAX}	≤ 15 feet

INSTALLATIONS			
	CANADA	U.S.A.	
A	12"	12"	Clearance above grade, veranda porch, deck or balcony.
B	12" Δ	9" Δ	Clearance to windows or doors that open.
C	12" *	12" *	Clearance to permanently closed windows.
D	18" **	18" **	Vertical clearance to ventilated soffits located above the terminal within a horizontal distance of 2' from the center line of the terminal.
E	12" **	12" **	Clearance to unventilated soffit.
F	0"	0"	Clearance to an outside corner wall.
G	0" ***	0" ***	Clearance to an inside non-combustible corner wall or protruding non-combustible obstructions (chimney, etc.).
	2" ***	2" ***	Clearance to an inside combustible corner wall or protruding combustible obstructions (vent chase, etc.).
H	3'	3' ****	Clearance to each side of the center line extended above the meter / regulator assembly to a maximum vertical distance of 15'.
I	3'	3' ****	Clearance to a service regulator vent outlet.
J	12"	9"	Clearance to a non-mechanical air supply inlet to the building or a combustion air inlet to any other appliance.
K	6'	3' †	Clearance to a mechanical air supply inlet.
L	7' ‡	7' ****	Clearance above a paved sidewalk or paved driveway located on public property.
M	12" ††	12" ****	Clearance under a veranda, porch or deck.
N	16"	16"	Clearance above the roof.
O	2' †*	2' †*	Clearance from an adjacent wall including neighbouring buildings.
P	8'	8'	Roof must be non-combustible without openings.
Q	3'	3'	See chart for wider wall dimensions.
R	6'	6'	See chart for deeper wall dimensions. The terminal shall not be installed on any wall that has an opening between the terminal and the open side of the structure.
S	12"	12"	Clearance under a covered balcony

Δ The terminal shall not be located less than 6 feet under a window that opens on a horizontal plane in a structure with three walls and a roof.

* Recommended to prevent condensation on windows and thermal breakage

** It is recommended to use a heat shield and to maximize the distance to vinyl clad soffits.

*** The periscope requires a minimum 18 inches clearance from an inside corner.

**** This is a recommended distance. For additional requirements check local codes.

† 3 feet above if within 10 feet horizontally.

‡ A vent shall not terminate where it may cause hazardous frost or ice accumulations on adjacent property surfaces.

†† Permitted only if the veranda, porch, or deck is fully open on a minimum of two sides beneath the floor.

†* Recommended to prevent recirculation of exhaust products. For additional requirements check local codes.

††* Permitted only if the balcony is fully open on a minimum of one side.

NOTE: Clearances are in accordance with local installation codes and the requirements of the gas supplier.

3.5 VENTING APPLICATION FLOW CHART

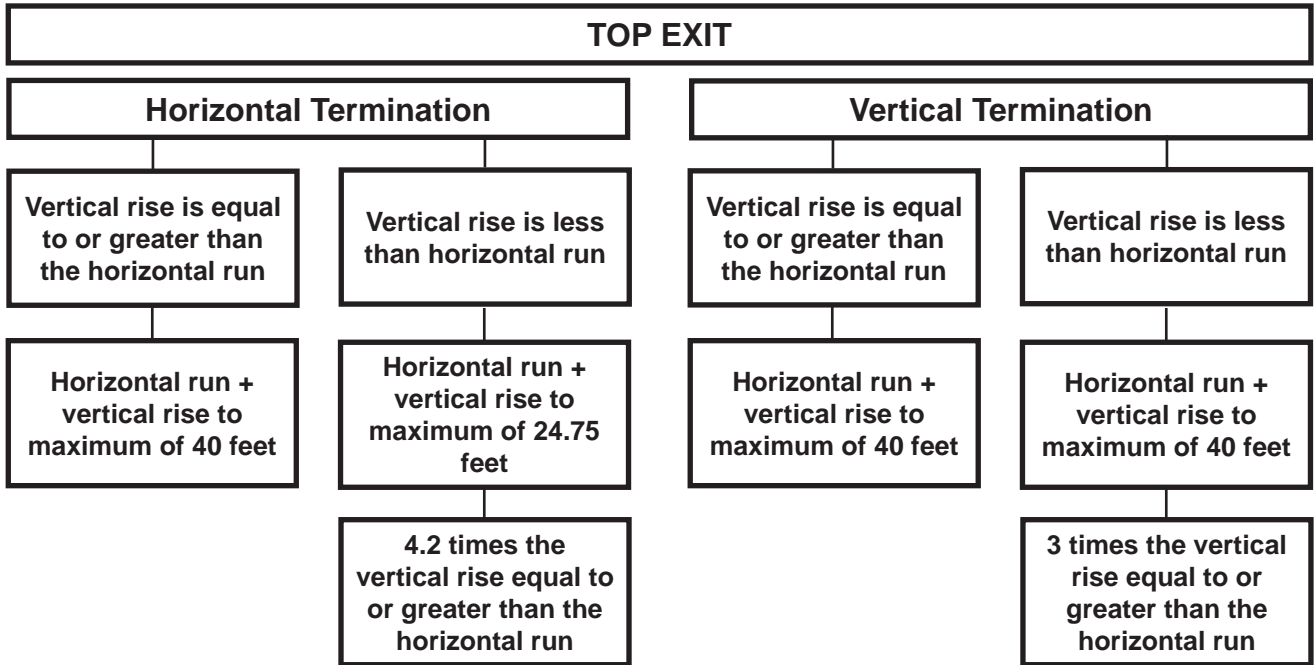

13.1

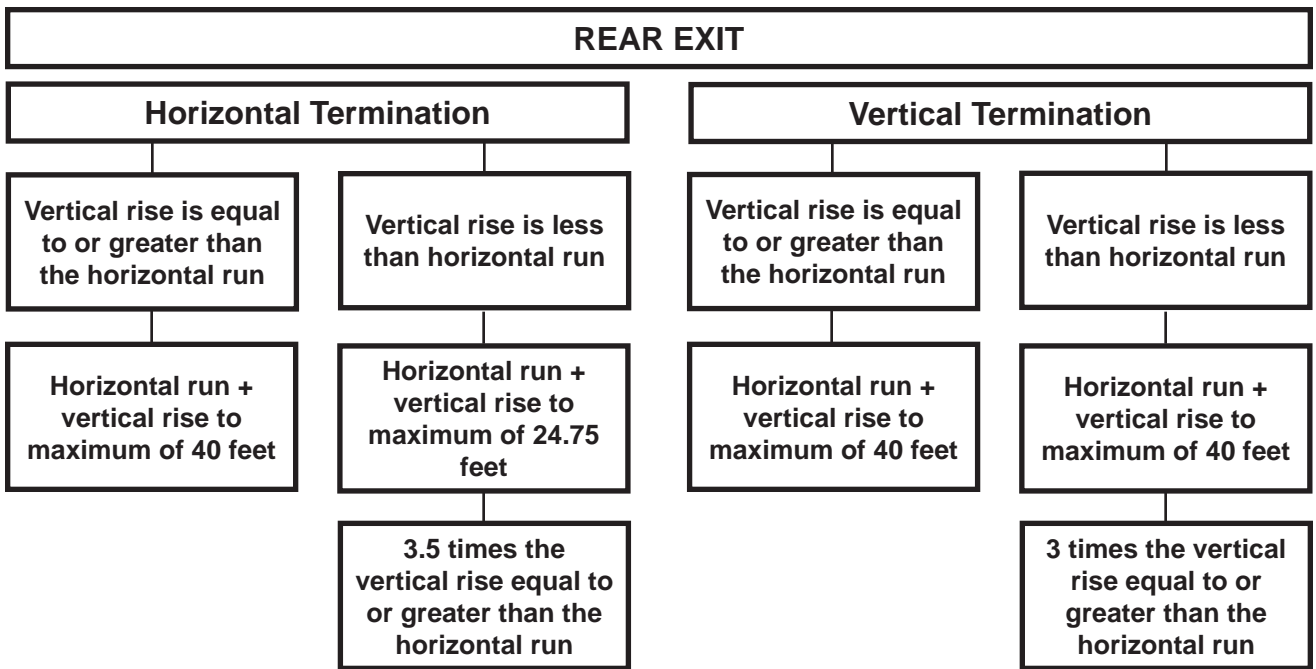

13.2

3.6 DEFINITIONS

For the following symbols used in the venting calculations and examples are:

> - greater than

≥ - equal to or greater than

< - less than

≤ - equal to or less than

H_T - total of both horizontal vent lengths (H_R) and offsets (H_O) in feet

H_R - combined horizontal vent lengths in feet

H_O - offset factor: .03 (total degrees of offset - 90°*) in feet

V_T - combined vertical vent lengths in feet

 14.1

3.7 ELBOW VENT LENGTH VALUES

	<u>FEET</u>	<u>INCHES</u>
1°	0.03	0.5
15°	0.45	6.0
30°	0.9	11.0
45°	1.35	16.0
90°*	2.7	32.0

* The first 90° offset has a zero value and is shown in the formula as - 90°

 15.1

3.8 TOP EXIT HORIZONTAL TERMINATION

$(H_T) > (V_T)$

Simple venting configuration (only one 90° elbow)

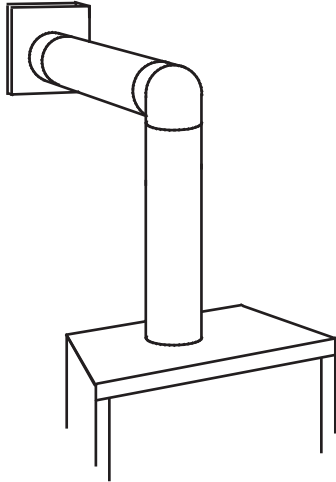

See graph to determine the required vertical rise V_T for the required horizontal run H_T .

REQUIRED VERTICAL RISE IN INCHES V_T

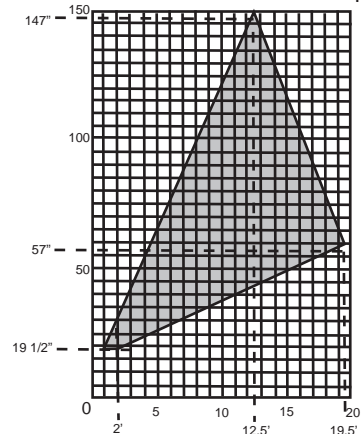

HORIZONTAL VENT RUN PLUS OFFSET IN FEET H_T
The shaded area within the lines represents acceptable values for H_T and V_T

For vent configurations requiring more than one 90° elbow, the following formulas apply:

Formula 1: $H_T \leq 4.2 V_T$

Formula 2: $H_T + V_T \leq 24.75$ feet

Example 2:

$V_1 = V_T = 6$ FT

$H_1 = 3$ FT

$H_2 = 5$ FT

$H_R = H_1 + H_2 = 3 + 5 = 8$ FT

$H_O = .03$ (two 90° elbows - 90°) = .03 (180° - 90°) = 2.7 FT

$H_T = H_R + H_O = 8 + 2.7 = 10.7$ FT

$H_T + V_T = 10.7 + 6 = 16.7$ FT

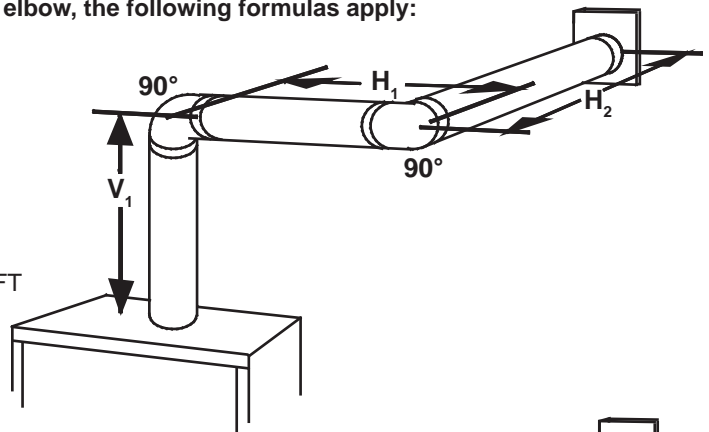

Formula 1: $H_T \leq 4.2 V_T$
 $4.2 V_T = 4.2 \times 6 = 25.2$ FT
 $10.7 \leq 25.2$

Formula 2: $H_T + V_T \leq 24.75$ FT
 $16.7 \leq 24.75$

Since both formulas are met, this vent configuration is acceptable.

Example 3:

$V_1 = 4$ FT

$V_2 = 1.5$ FT

$V_T = V_1 + V_2 = 4 + 1.5 = 5.5$ FT

$H_1 = 2$ FT

$H_2 = 1$ FT

$H_3 = 1$ FT

$H_4 = 1.5$ FT

$H_R = H_1 + H_2 + H_3 + H_4 = 2 + 1 + 1 + 1.5 = 5.5$ FT

$H_O = .03$ (four 90° elbows - 90°) = .03 (360° - 90°) = 8.1 FT

$H_T = H_R + H_O = 5.5 + 8.1 = 13.6$ FT

$H_T + V_T = 13.6 + 5.5 = 19.1$ FT

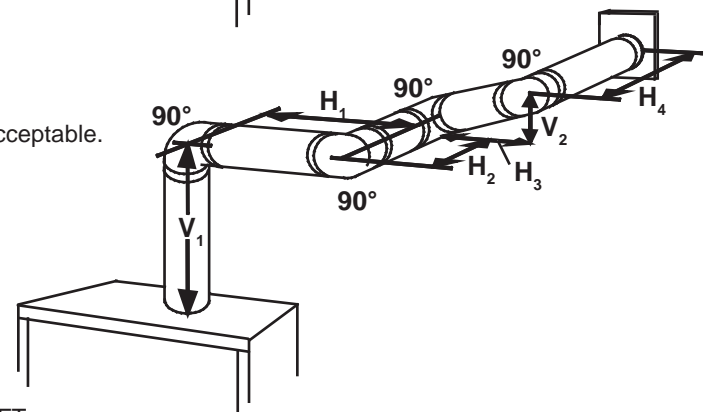

Formula 1: $H_T \leq 4.2 V_T$
 $4.2 V_T = 4.2 \times 5.5 = 23.1$ FT
 $13.6 \leq 23.1$

Formula 2: $H_T + V_T \leq 24.75$ FT
 $19.1 \leq 24.75$

Since both formulas are met, this vent configuration is acceptable.

3.9 TOP EXIT HORIZONTAL TERMINATION

$(H_T) \leq (V_T)$

Simple venting configuration (only one 90° elbow)

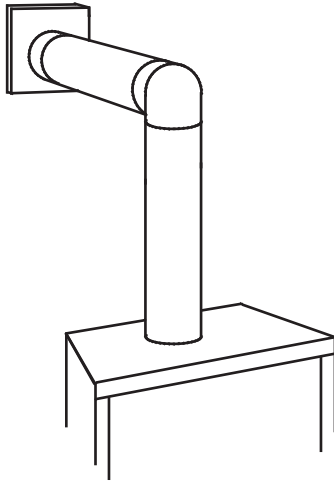

See graph to determine the required vertical rise V_T for the required horizontal run H_T

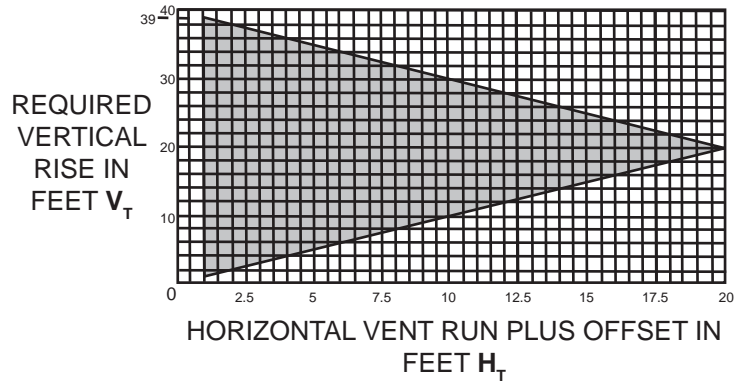

The shaded area within the lines represents acceptable values for H_T and V_T

For vent configurations requiring more than one 90° elbow, the following formulas apply:

Formula 1: $H_T \leq V_T$

Formula 2: $H_T + V_T \leq 40$ feet

Example 1:

$V_1 = 3$ FT

$V_2 = 8$ FT

$V_T = V_1 + V_2 = 3$ FT + 8 FT = 11 FT

$H_1 = 2.5$ FT

$H_2 = 2$ FT

$H_R = H_1 + H_2 = 2.5 + 2 = 4.5$ FT

$H_O = .03$ (three 90° elbows - 90°) = .03 (270° - 90°) = 5.4 FT

$H_T = H_R + H_O = 4.5 + 5.4 = 9.9$ FT

$H_T + V_T = 9.9 + 11 = 20.9$ FT

Formula 1: $H_T \leq V_T$

$9.9 \leq 11$

Formula 2: $H_T + V_T \leq 40$ FT

$20.9 \leq 40$

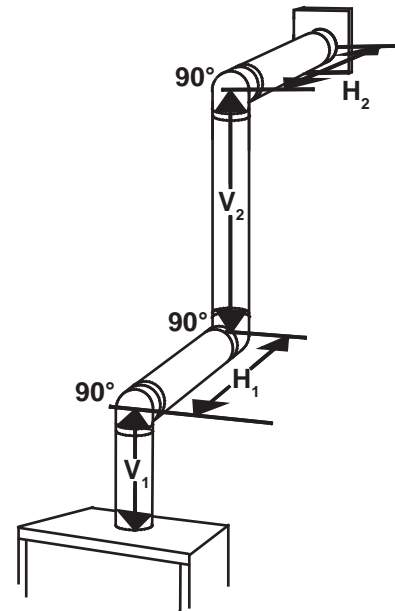

Since both formulas are met, this vent configuration is acceptable.

16.1A

3.10 REAR EXIT HORIZONTAL TERMINATION

$$(H_T) \leq (V_T)$$

Simple venting configuration
(only two 90° elbows)

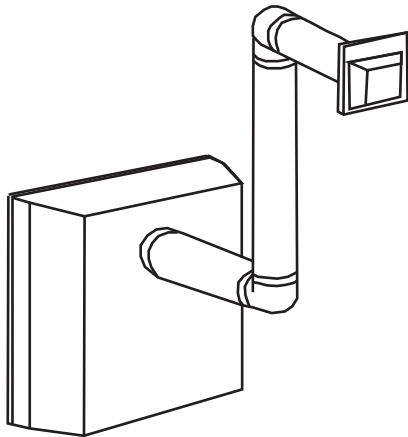

See graph to determine the required vertical rise V_T for the required horizontal run H_T .

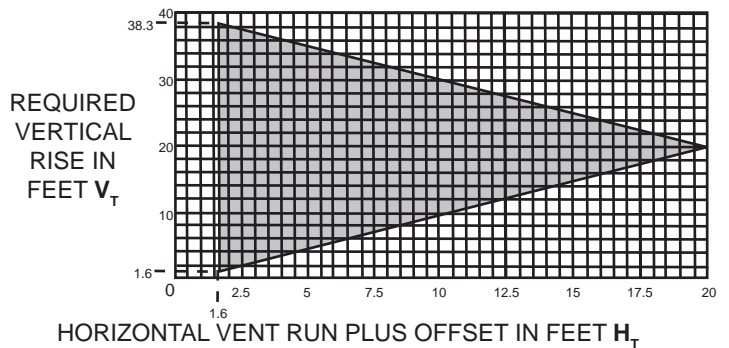

The shaded area within the lines represents acceptable values for H_T and V_T

For vent configurations requiring more than two 90° elbows, the following formulas apply:

Formula 1: $H_T \leq V_T$

Formula 2: $H_T + V_T \leq 40$ feet

Example:

$V_1 = 9$ FT

$V_2 = 6$ FT

$V_T = V_1 + V_2 = 9 + 6 = 15$ FT

$H_1 = 3$ FT

$H_2 = 2$ FT

$H_3 = 1.5$ FT

$H_R = H_1 + H_2 + H_3 = 3 + 2 + 1.5 = 6.5$ FT

$H_O = .03$ (four 90° elbows - 90°) = $.03(360^\circ - 90^\circ) = 8.1$ FT

$H_T = H_R + H_O = 6.5 + 8.1 = 14.6$ FT

$H_T + V_T = 14.6 + 15 = 29.6$ FT

Formula 1: $H_T \leq V_T$
 $14.6 \leq 15$

Formula 2: $H_T + V_T \leq 40$ FT
 $29.6 \leq 40$

Since both formulas are met, this vent configuration is acceptable.

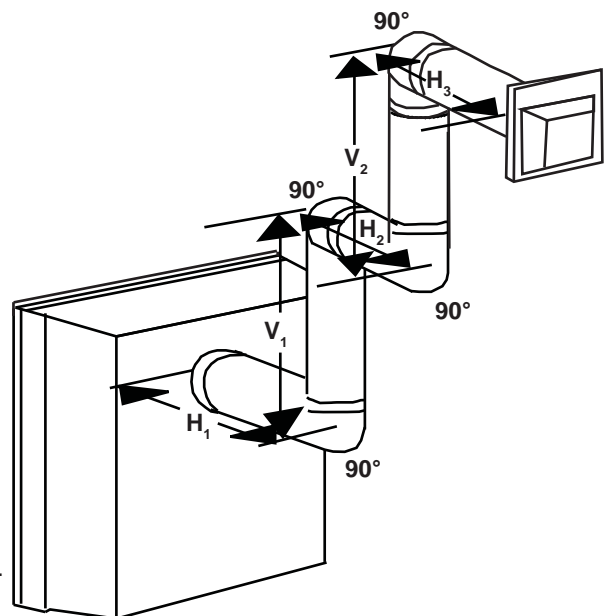

$$(H_T) > (V_T)$$

**Simple venting configuration
(only two 90° elbows)**

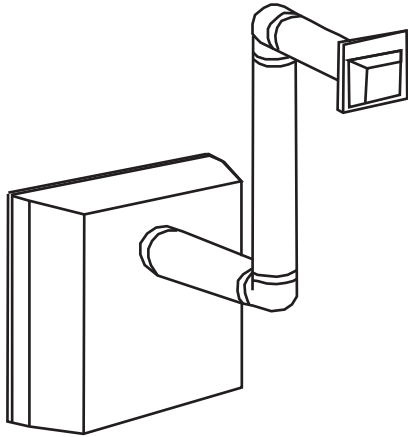

See graph to determine the required vertical rise V_T for the required horizontal run H_T .

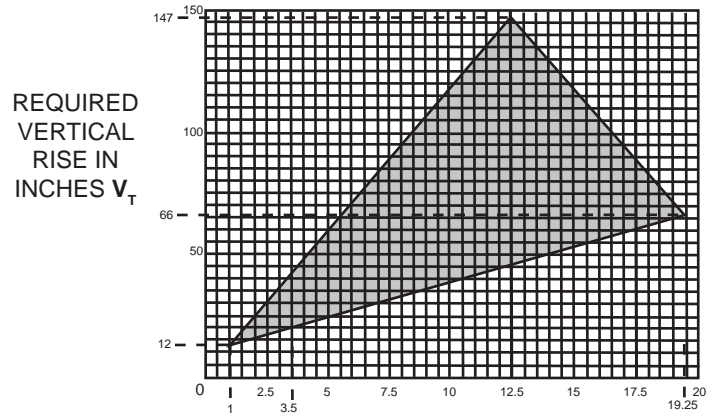

HORIZONTAL VENT RUN PLUS OFFSET IN FEET H_T
The shaded area within the lines represents acceptable values for H_T and V_T

For vent configurations requiring more than two 90° elbows, the following formulas apply:

Formula 1: $H_T \leq 3.5V_T$

Formula 2: $H_T + V_T \leq 24.75$ feet

Example:

$V_1 = 4$ FT

$V_2 = 1.5$ FT

$V_T = V_1 + V_2 = 4 + 1.5 = 5.5$ FT

$H_1 = 2$ FT

$H_2 = 1$ FT

$H_3 = 1$ FT

$H_4 = 1.5$ FT

$H_R = H_1 + H_2 + H_3 + H_4 = 2 + 1 + 1 + 1.5 = 5.5$ FT

$H_O = .03$ (four 90° elbows + one 45° elbow - 90°)

$= .03 (90 + 90 + 90 + 90 + 45 - 90) = 9.45$ FT

$H_T = H_R + H_O = 5.5 + 9.45 = 14.95$ FT

$H_T + V_T = 14.95 + 5.5 = 20.45$ FT

Formula 1: $H_T \leq 3.5V_T$
 $3.5V_T = 3.5 \times 5.5 = 19.25$ FT

$14.95 \leq 19.25$

Formula 2: $H_T + V_T \leq 24.75$ FT

$20.45 \leq 24.75$

Since both formulas are met, this vent configuration is acceptable.

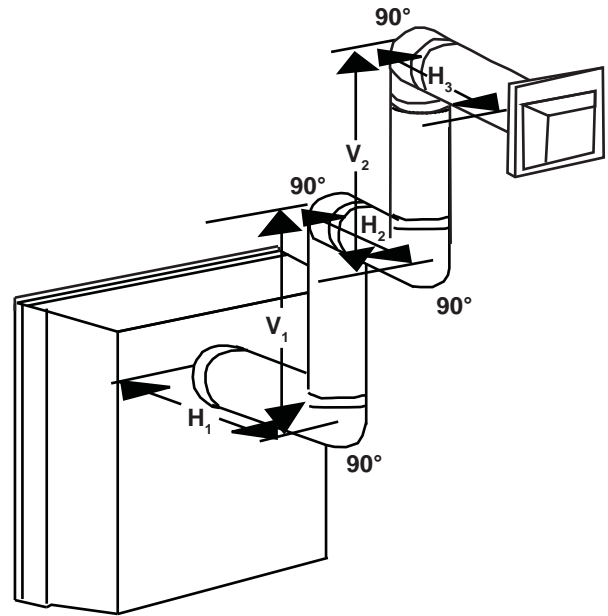

3.11 TOP OR REAR EXIT VERTICAL TERMINATION

$$(H_T) \leq (V_T)$$

Simple venting configurations.

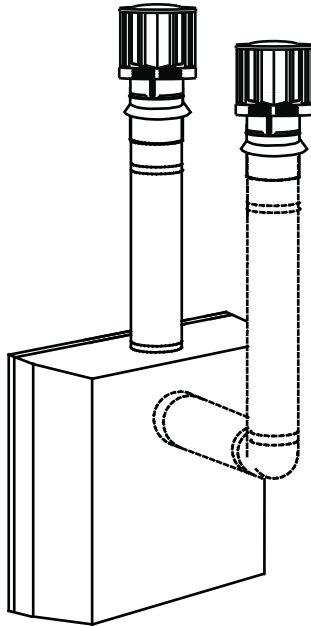

See graph to determine the required vertical rise V_T for the required horizontal run H_T .

REQUIRED VERTICAL RISE IN FEET V_T

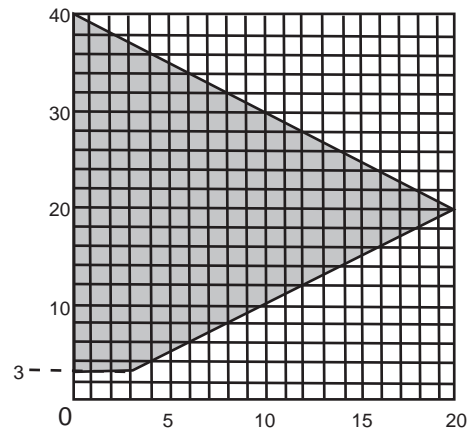

HORIZONTAL VENT RUN PLUS OFFSET IN FEET H_T

The shaded area within the lines represents acceptable values for H_T and V_T

For vent configurations requiring one or more 90° elbows (top exit) or one or more 90° elbows (rear exit), the following formulas apply:

Formula 1: $H_T \leq V_T$

Formula 2: $H_T + V_T \leq 40$ feet

Example:

$V_1 = 5$ FT

$V_2 = 6$ FT

$V_3 = 10$ FT

$V_T = V_1 + V_2 + V_3 = 5 + 6 + 10 = 21$ FT

$H_1 = 8$ FT

$H_2 = 2.5$ FT

$H_R = H_1 + H_2 = 8 + 2.5 = 10.5$ FT

$H_o = .03$ (four 90° elbows - 90°)

$= .03$ (360° - 90°) = 8.1 FT

$H_T = H_R + H_o = 10.5 + 8.1 = 18.6$ FT

$H_T + V_T = 18.6 + 21 = 39.6$ FT

Formula 1: $H_T \leq 3.5 V_T$
 $18.6 \leq 21$

Formula 2: $H_T + V_T \leq 40$ FT
 $39.6 \leq 40$

Since both formulas are met, this vent configuration is acceptable.

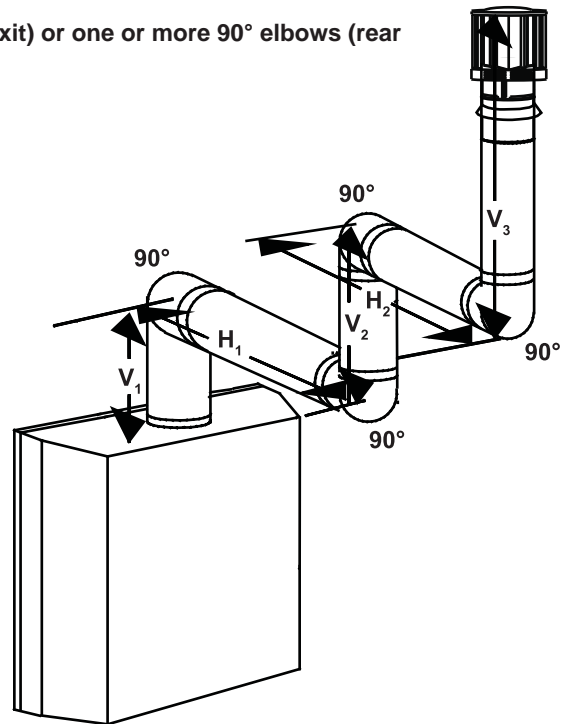

$$(H_T) > (V_T)$$

Simple venting configurations.

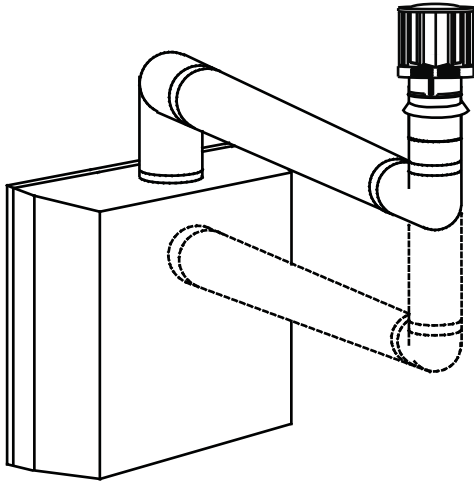

See graph to determine the required vertical rise V_T for the required horizontal run H_T .

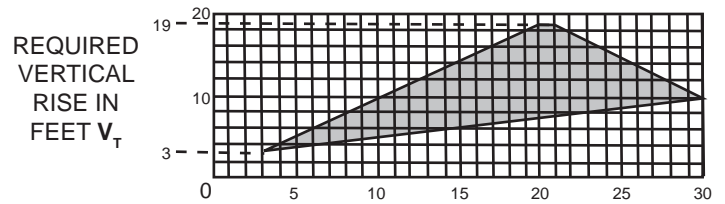

HORIZONTAL VENT RUN PLUS OFFSET IN FEET H_T

The shaded area within the lines represents acceptable values for H_T and V_T

For vent configurations requiring more than two 90° elbows (top exit) or one 90° elbow (rear exit), the following formulas apply:

Formula 1: $H_T \leq 3 V_T$

Formula 2: $H_T + V_T \leq 40$ feet

Example 7:

$$V_1 = 2 \text{ FT}$$

$$V_2 = 1 \text{ FT}$$

$$V_3 = 1.5 \text{ FT}$$

$$V_T = V_1 + V_2 + V_3 = 2 + 1 + 1.5 = 4.5 \text{ FT}$$

$$H_1 = 6 \text{ FT}$$

$$H_2 = 2 \text{ FT}$$

$$H_R = H_1 + H_2 = 6 + 2 = 8 \text{ FT}$$

$$H_O = .03 \text{ (four } 90^\circ \text{ elbows } - 90^\circ)$$

$$= .03 \text{ (} 360^\circ - 90^\circ) = 8.1 \text{ FT}$$

$$H_T = H_R + H_O = 8 + 8.1 = 16.1 \text{ FT}$$

$$H_T + V_T = 16.1 + 4.5 = 20.6 \text{ FT}$$

Formula 1: $H_T \leq 3.5 V_T$
 $3.5 V_T = 3 \times 4.5 = 13.5 \text{ FT}$
 $16.1 \leq 13.5$

Since this formula is not met, this vent configuration is **unacceptable**.

Formula 2: $H_T + V_T \leq 40 \text{ FT}$
 $16.1 \leq 13.5$

Since only formula 2 is met, this vent configuration is unacceptable and a new fireplace location or vent configuration will need to be established to satisfy both formulas.

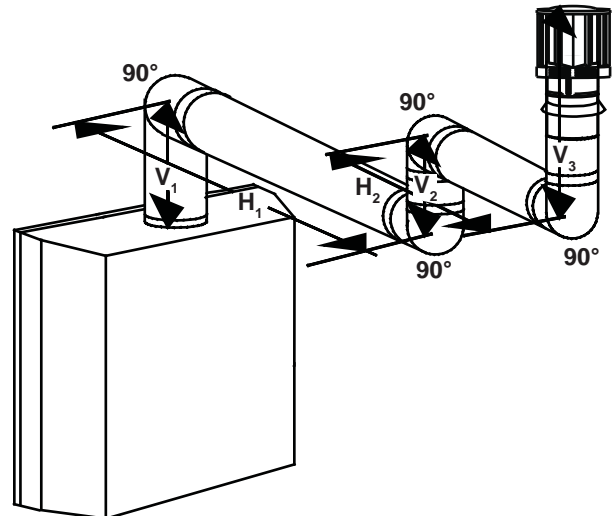

18.2_2A

Example:

$$V_1 = 1.5 \text{ FT}$$

$$V_2 = 5 \text{ FT}$$

$$V_T = V_1 + V_2 = 1.5 + 1 + 5 = 6.5 \text{ FT}$$

$$H_1 = 1 \text{ FT}$$

$$H_2 = 1 \text{ FT}$$

$$H_3 = 10.75 \text{ FT}$$

$$H_R = H_1 + H_2 + H_3 = 1 + 1 + 10.75 = 12.75 \text{ FT}$$

$$H_O = .03 \text{ (four } 90^\circ \text{ elbows + one } 45^\circ \text{ elbow - } 90^\circ)$$

$$= .03 (360^\circ + 45^\circ - 90^\circ) = 6.75 \text{ FT}$$

$$H_T = H_R + H_O = 12.75 + 6.75 = 19.5 \text{ FT}$$

$$H_T + V_T = 19.5 + 6.5 = 26 \text{ FT}$$

Formula 1:

$$H_T \leq 3 V_T$$

$$3 V_T = 3 \times 6.5 = 19.5 \text{ FT}$$

$$19.5 = 19.5$$

Formula 2:

$$H_T + V_T \leq 40 \text{ FT}$$

$$26 \leq 40$$

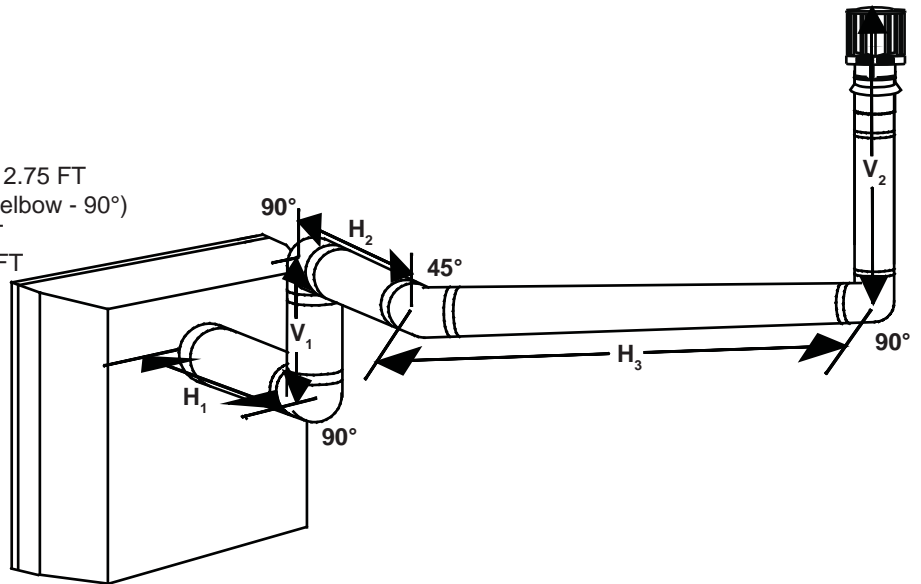

Since both formulas are met, this vent configuration is acceptable.

18.2_3

4.0 INSTALLATION PREPARATION - MODEL GDS60

4.1 ORIFICE REPLACEMENT

REAR VENT TERMINATION:

In rear exit installations with no vertical vent run, the BTU input must be reduced to 21,000 BTU by changing the orifice.

In order to access the orifice, the log support secured by two screws, must be removed.

Care should be taken not to damage the gas pipe. When removing the orifice, using a socket wrench, a back-up wrench must be used on the manifold, located below the housing, to ensure that the aluminum tubing does not twist or kink.

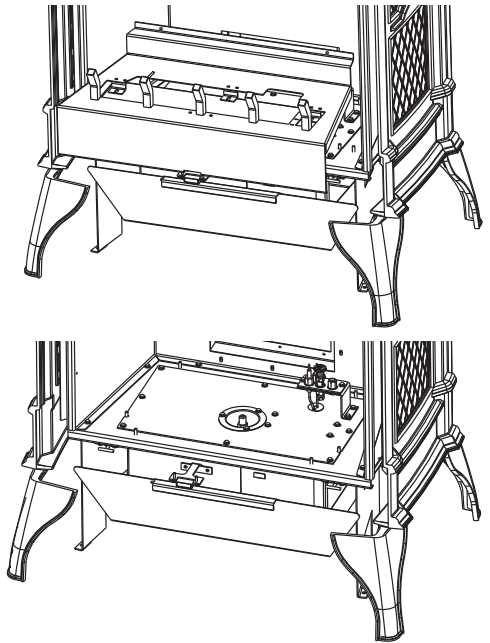

4.2 CHANGING A TOP VENT TO A REAR VENT

In order to convert the venting configuration from a top exit to a rear exit, remove components as illustrated. When reinstalling in the alternate position: Check gaskets for tears, replace if necessary to ensure a proper seal.

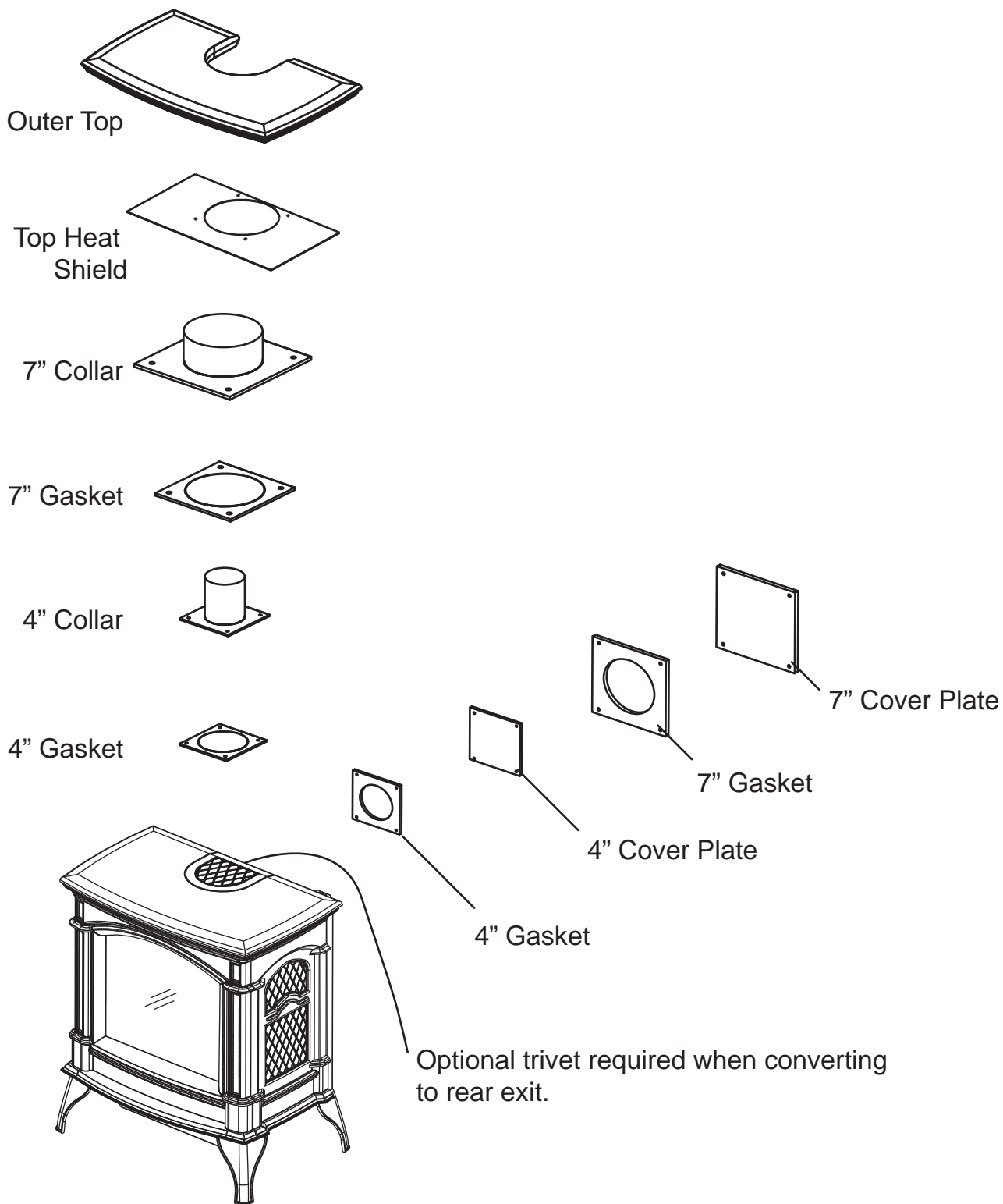

5.0 INSTALLATION

! WARNING
FOR SAFE AND PROPER OPERATION OF THE APPLIANCE, FOLLOW THE VENTING INSTRUCTIONS EXACTLY.
ALL INNER EXHAUST AND OUTER INTAKE VENT PIPE JOINTS MAY BE SEALED USING EITHER RED RTV HIGH TEMP SILICONE SEALANT W573-0002 (NOT SUPPLIED) OR BLACK HIGH TEMP MILL PAC W573-0007 (NOT SUPPLIED) WITH THE EXCEPTION OF THE APPLIANCE EXHAUST FLUE COLLAR WHICH MUST BE SEALED USING MILL PAC.
IF USING PIPE CLAMPS TO CONNECT VENT COMPONENTS, 3 SCREWS MUST ALSO BE USED TO ENSURE THE CONNECTION CANNOT SLIP OFF.
DO NOT CLAMP THE FLEXIBLE VENT PIPE.
RISK OF FIRE, EXPLOSION OR ASPHYXIATION. IMPROPER SUPPORT OF THE ENTIRE VENTING SYSTEM MAY ALLOW VENT TO SAG AND SEPARATE. USE VENT RUN SUPPORTS AND CONNECT VENT SECTIONS PER INSTALLATION INSTRUCTIONS.
RISK OF FIRE, DO NOT ALLOW LOOSE MATERIALS OR INSULATION TO TOUCH THE VENT PIPE. REMOVE INSULATION TO ALLOW FOR THE INSTALLATION OF THE ATTIC SHIELD AND TO MAINTAIN CLEARANCES TO COMBUSTIBLES.

68.2A

5.1 MINIMUM CLEARANCE TO COMBUSTIBLES

GDS60:

HORIZONTAL VENT SECTIONS: A minimum clearance of 2" at the top and 1" at the bottom and sides of the vent pipe on all horizontal runs is required.

VERTICAL VENT SECTIONS: A minimum of 1" all around the vent pipe on all vertical runs to combustibles is required.

GS60:

A minimum of 1" all around the B vent pipe on both horizontal and vertical runs to combustibles is required.

MAINTAIN THESE MINIMUM CLEARANCES TO COMBUSTIBLES:

A. 6" B. 6" C. 2"*

No additional floor protection is required.

Minimum 20" from appliance top to ceiling.

6" to single wall connector.

*At a distance of 2" from the wall, access to the blower switch, on-off switch or the blower power cord may not be practical.

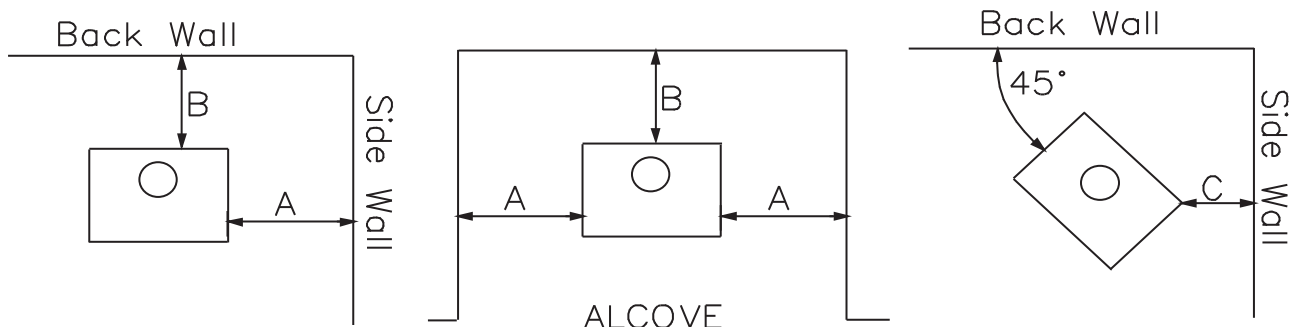

5.2 WALL AND CEILING PROTECTION

! WARNING

DO NOT FILL THE SPACE BETWEEN THE VENT PIPE AND ENCLOSURE WITH ANY TYPE OF MATERIAL. DO NOT PACK INSULATION OR COMBUSTIBLES BETWEEN CEILING FIRESTOPS. ALWAYS MAINTAIN SPECIFIED CLEARANCES AROUND VENTING AND FIRESTOP SYSTEMS. INSTALL WALL SHIELDS AND FIRESTOPS AS SPECIFIED. FAILURE TO KEEP INSULATION OR OTHER MATERIALS AWAY FROM VENT PIPE MAY CAUSE FIRE.

70.1

For optimum performance, it is recommended that all horizontal runs have a minimum 1/4" rise per foot when venting. For safe and proper operation of the appliance, follow the venting instructions exactly.

5.2.1 HORIZONTAL INSTALLATION

! WARNING

THE FIRESTOP ASSEMBLY MUST BE INSTALLED WITH THE VENT SHIELD TO THE TOP.

TERMINALS MUST NOT BE RECESSED INTO A WALL OR SIDING MORE THAN THE DEPTH OF THE RETURN FLANGE OF THE MOUNTING PLATE.

This application occurs when venting through an exterior wall. Having determined the correct height for the air terminal location, cut and frame a hole in the exterior wall as illustrated to accommodate the firestop assembly. Dry fit the firestop assembly before proceeding to ensure the brackets on the rear surface fit to the inside surface of the horizontal framing.

The length of the vent shield may be cut shorter for combustible walls that are less than 8 1/2" thick but the vent shield must extend the full depth of the combustible wall.

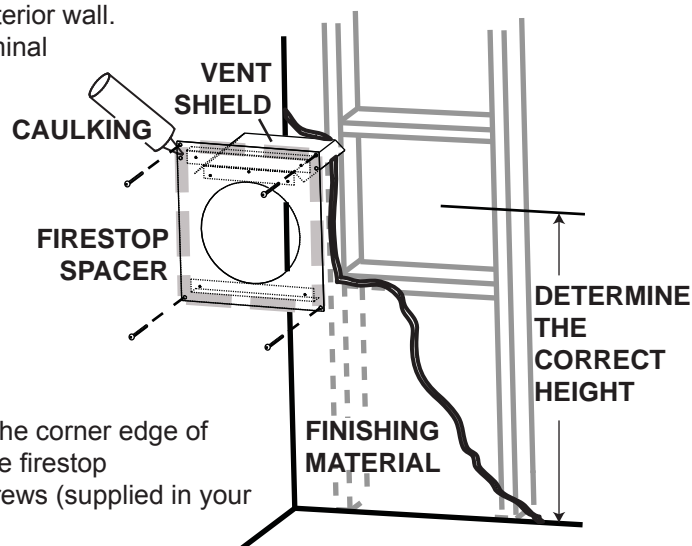

- A. Apply a bead of caulking (not supplied) around the corner edge of the inside surface of the firestop assembly, fit the firestop assembly to the hole and secure using the 4 screws (supplied in your manual baggie).
- B. Once the vent pipe is installed in its final position, apply high temperature sealant W573-0007 (not supplied) between the pipe and the firestop.

20.2

5.2.2 VERTICAL INSTALLATION

This application occurs when venting through a roof. Installation kits for various roof pitches are available from your authorized dealer / distributor. See accessories to order specific kits required.

- A. Determine the air terminal location, cut and frame a square opening as illustrated in the ceiling and the roof to provide the minimum 1" clearance between the vent pipe and any combustible material. Try to center the vent pipe location midway between two joists to prevent having to cut them. Use a plumb bob to line up the center of the openings. A vent pipe shield will prevent any materials such as insulation, from filling up the 1" air space around the pipe. Nail headers between the joist for extra support.
- B. Apply a bead of caulking (not supplied) to the framework or to the Wolf Steel vent pipe shield plate or equivalent (in the case of a finished ceiling), and secure over the opening in the ceiling. A firestop must be placed on the bottom of each framed opening in a roof or ceiling that the venting system passes through. Apply a bead of caulking all around and place a firestop spacer over the vent shield to restrict cold air from being drawn into the room or around the fireplace. Ensure that both spacer and shield maintain the required clearance to combustibles. Once the vent pipe is installed in its final position, apply sealant between the pipe and the firestop assembly.
- C. In the attic, slide the vent pipe collar down to cover up the open end of the shield and tighten. This will prevent any materials, such as insulation, from filling up the 1" air space around the pipe.

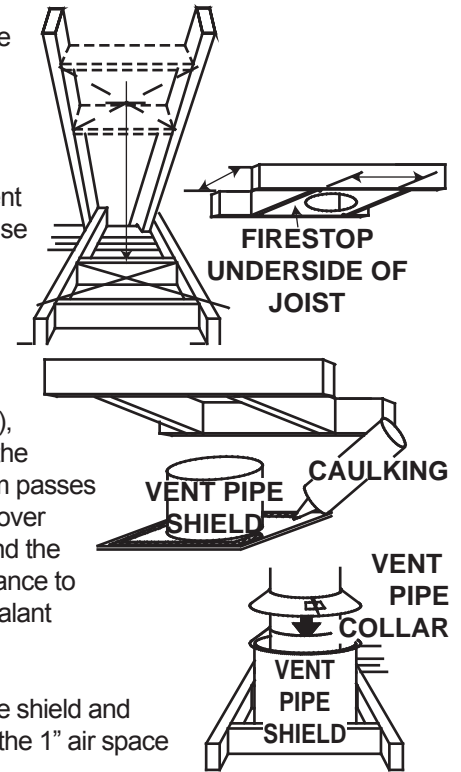

21.1

5.2.3 HORIZONTAL AIR TERMINAL INSTALLATION - MODEL GDS60

! WARNING

TERMINALS MUST NOT BE RECESSED INTO A WALL OR SIDING MORE THAN THE DEPTH OF THE RETURN FLANGE OF THE MOUNTING PLATE.

- A. Stretch the inner flex pipe to the required length taking into account the additional length needed for the finished wall surface. Slip the vent pipe a minimum of 2" over the inner sleeve of the air terminal and secure with 3 #8 screws. Apply a heavy bead of the high temperature sealant W573-0007 Mill Pac (not supplied).

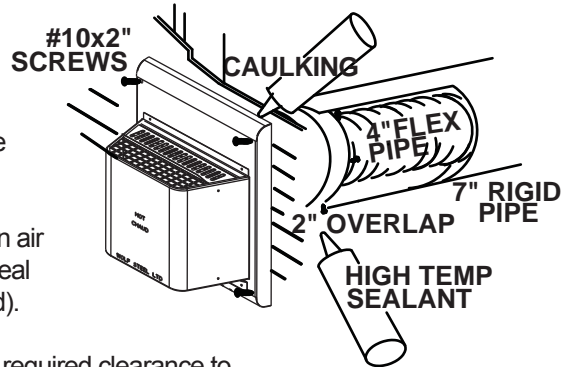

- B. Using the outer rigid pipe, slide over the outer combustion air sleeve of the air terminal and secure with 3 #8 screws. Seal using high temperature sealant W573-0002 (not supplied).

- C. Insert the vent pipes through the firestop maintaining the required clearance to combustibles. Holding the air terminal (lettering in an upright, readable position), secure to the exterior wall and make weather tight by sealing with caulking (not supplied).

- D. From inside the house, using silicone, seal between the vent pipe and the firestop. Then slide the black trim collar over the vent pipe up to the firestop.

- E. If more vent pipe needs to be used to reach the appliance, couple them together as illustrated. The vent system must be supported approximately every 3 feet for both vertical and horizontal runs. Use noncombustible strapping to maintain the minimum clearance to combustibles.

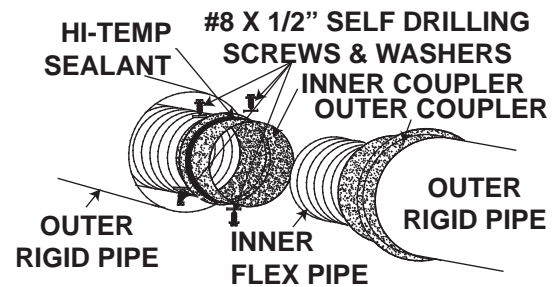

The air terminal mounting plate may be recessed into the exterior wall or siding no greater than the depth of its return flange.

23.7A

5.2.4 VERTICAL AIR TERMINAL INSTALLATION - MODEL GDS60

! WARNING**MAINTAIN A MINIMUM 2" SPACE BETWEEN THE AIR INLET BASE AND THE STORM COLLAR.**

- A.** Fasten the roof support to the roof using the screws provided. The roof support is optional. In this case the venting is to be adequately supported using either an alternate method suitable to the authority having jurisdiction or the optional roof support.
- B.** Stretch the inner flex pipe to the required length. Slip the inner flex pipe a minimum of 2" over the inner pipe of the air terminal connector and secure with 3 #8 screws. Seal using a heavy bead of high temperature sealant W573-0007 (not supplied).
- C.** Repeat using the outer flex pipe, using a heavy bead of high temperature sealant W573-0002 (not supplied).
- D.** Thread the air terminal connector / vent pipe assembly down through the roof. The air terminal must be positioned vertically and plumb. Attach the air terminal connector to the roof support, ensuring that the top of the air terminal is 16" above the highest point that it penetrates the roof.
- E.** Remove nails from the shingles, above and to the sides of the air terminal connector. Place the flashing over the air terminal connector leaving a min. 3/4" of the air terminal connector showing above the top of the flashing. Slide the flashing underneath the sides and upper edge of the shingles. Ensure that the air terminal connector is properly centred within the flashing, giving a 3/4" margin all around. Fasten to the roof. Do not nail through the lower portion of the flashing. Make weather-tight by sealing with caulking. Where possible, cover the sides and top edges of the flashing with roofing material.
- F.** Aligning the seams of the terminal and air terminal connector, place the terminal over the air terminal connector making sure the vent pipe goes into the hole in the terminal. Secure with the three screws provided.
- G.** Apply a heavy bead of weatherproof caulking 2" above the flashing. Install the storm collar around the air terminal and slide down to the caulking. Tighten to ensure that a weather-tight seal between the air terminal and the collar is achieved.
- H.** If more vent pipe needs to be used to reach the appliance see "HORIZONTAL AIR TERMINAL INSTALLATION" section.

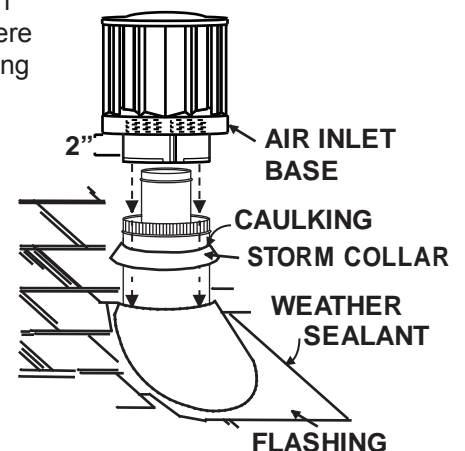
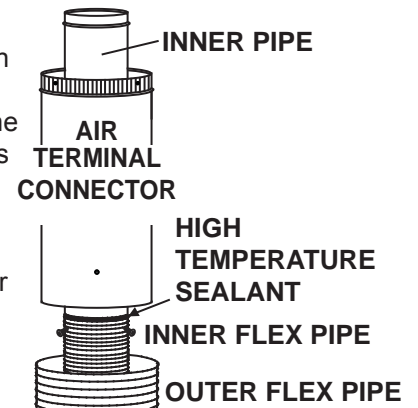
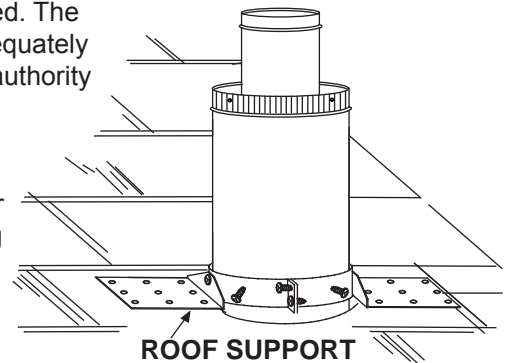

5.3 APPLIANCE VENT CONNECTION - MODEL GDS60

- A. Attach the adjustable pipe to the last section of rigid pipe. Secure with screws and seal.
- B. Install the inner flex pipe to the appliance. Secure with 3 screws and flat washers. Seal the joint and screw holes using the high temperature sealant W573-0007 (not supplied).
- C. Run a bead of high temperature sealant (not supplied) around the inside of the air intake collar. Pull the adjustable pipe a minimum 2" into the air intake collar.

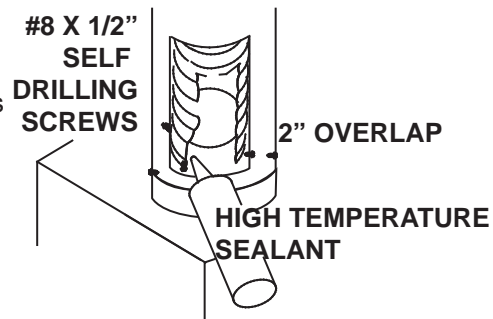

NOTE: Ensure that the sealant is not visible on the exterior pipes once installation is completed. An optional decorative black band is available for this use. In the event that the venting must be disassembled, care must be taken to reseal the venting.

28.3

5.4 MOBILE HOME INSTALLATION - MODEL GDS60

In Canada, mobile home installation may be vented horizontally or vertically. In the United States, it may only be installed vertically. See "VERTICAL VENTING" or "HORIZONTAL AIR TERMINAL INSTALLATION" section for installation.

For mobile home installations, the appliance must be fastened in place. It is recommended that the appliance be secured in all installations. Use the levelling / securing kit, GDSLL-KT for this purpose.

5.5 GAS INSTALLATION

 WARNING
RISK OF FIRE, EXPLOSION OR ASPHYXIATION. ENSURE THERE ARE NO IGNITION SOURCES SUCH AS SPARKS OR OPEN FLAMES.
SUPPORT GAS CONTROL WHEN ATTACHING GAS SUPPLY PIPE TO PREVENT DAMAGING GAS LINE.
ALWAYS LIGHT THE PILOT WHETHER FOR THE FIRST TIME OR IF THE GAS SUPPLY HAS RUN OUT WITH THE GLASS DOOR OPENED OR REMOVED. PURGING OF THE GAS SUPPLY LINE SHOULD BE PERFORMED BY A QUALIFIED SERVICE TECHNICIAN. ASSURE THAT A CONTINUOUS GAS FLOW IS AT THE BURNER BEFORE CLOSING THE DOOR. ENSURE ADEQUATE VENTILATION. FOR GAS AND ELECTRICAL LOCATIONS, SEE "DIMENSION" SECTION.
ALL GAS CONNECTIONS MUST BE CONTAINED WITHIN THE APPLIANCE WHEN COMPLETE.
HIGH PRESSURE WILL DAMAGE VALVE. DISCONNECT GAS SUPPLY PIPING BEFORE TESTING GAS LINE AT TEST PRESSURES ABOVE 1/2 PSIG.
VALVE SETTINGS HAVE BEEN FACTORY SET, DO NOT CHANGE.

Installation and servicing to be done by a qualified installer. **Do not use open flame.**

- A. Move the appliance into position and secure.
- B. If equipped with a flex connector the appliance is designed to accept a 1/2" gas supply. Without the connector it is designed to accept a 3/8" gas supply. The appliance is equipped with a manual shut off valve to turn off the gas supply to the appliance.
- C. Connect the gas supply in accordance to local codes. In the absence of local codes, install to the current CAN/CSA-B149.1 Installation Code in Canada or to the current National Fuel Gas Code, ANSI Z223.1 / NFPA 54 in the United States.
- D. When flexing any gas line, support the gas valve so that the lines are not bent or kinked.
- E. The gas line flex-connector should be installed to provide sufficient movement for shifting the burner assembly on it's side to aid with servicing components.
- F. Check for gas leaks by brushing on a soap and water solution.

30.1A

5.6 OPTIONAL WALL SWITCH / THERMOSTAT

For ease of accessibility, an optional remote wall switch or millivolt thermostat may be installed in a convenient location. Route 2 strand solid core millivolt wire from the gas appliance to the wall switch / millivolt thermostat. The recommended maximum lead length depends on the wire size:

WIRE SIZE	MAX. LENGTH
14 gauge	100 feet
16 gauge	60 feet
18 gauge	40 feet

DIRECT VENT MODEL GDS60: Disconnect one of the wire leads to the on/off switch then connect the wire leads from the optional thermostat / wall switch / remote. See "WIRING DIAGRAM" section.

B-VENT MODEL GS60: Disconnect one of the wire leads to the on/off switch then connect the wire leads from the optional thermostat / wall switch / remote / spill switch to "B" vent adaptor. See "WIRING DIAGRAM" section.

5.7 B-VENT SPECIFICS - MODEL GS60

5.7.1 CHIMNEY INSTALLATION

! WARNING

A CHIMNEY VENTING THIS APPLIANCE SHALL NOT VENT ANY SOLID FUEL BURNING APPLIANCE.

Three types of chimney systems may be used with this appliance.

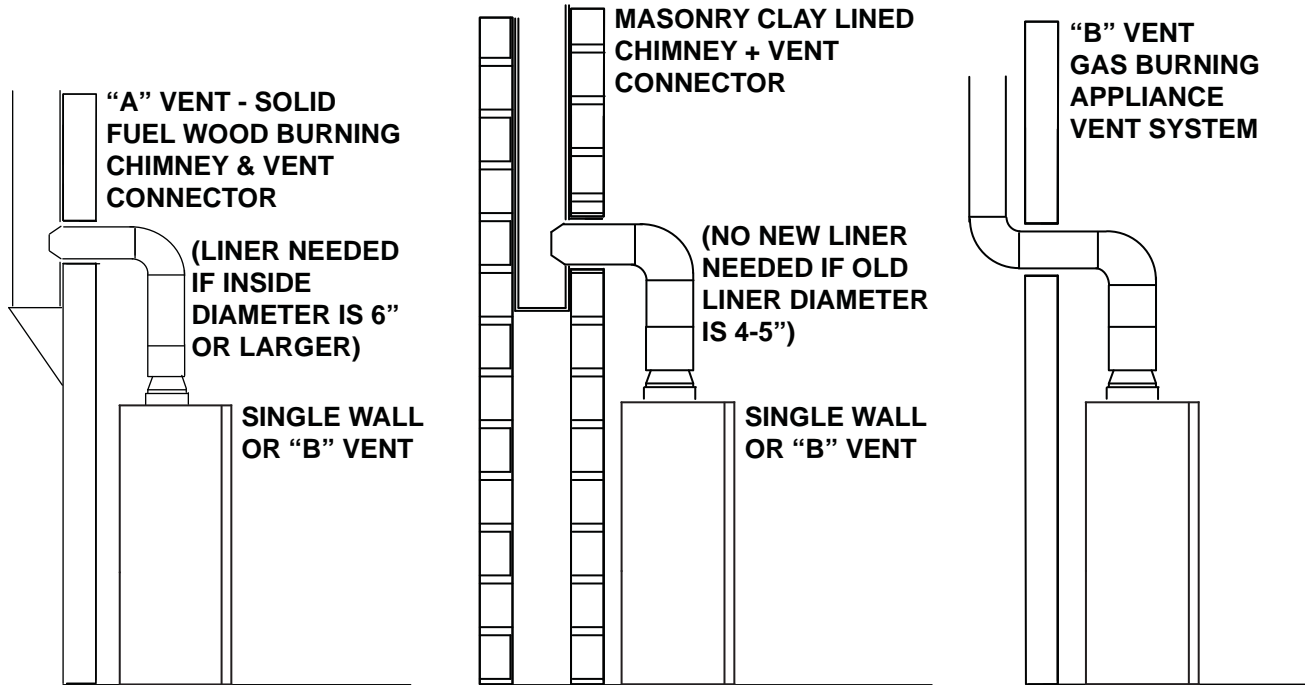

A chimney venting this appliance shall not vent any solid fuel burning appliance.
 All horizontal runs must have a 1/4" rise per foot

5.7.2 INSTALLING "B" VENT

Follow the instructions of the "B" vent manufacturer for chimney installation.

- A. Remove the access plate. Remove and discard the air intake cover plate located directly behind the access plate.
- B. Feed the 2 wires, supplied, through the 7" collar at the top of the unit, bring them out the air intake opening but behind the rear panel as shown.

NOTE: Ensure that 2 female ends remain at the top. Re-secure the access plate.

- C. Remove the spill switch bracket from the rear of the adapter. Unscrew the spill switch and discard the bracket. Attach the spill switch to the bracket supplied with the appliance and secure onto the adapter.
- D. Bring the wires through the lower hole in the adapter. To pass the wires through the hole more easily, temporarily tape the two terminals together.
- E. With the spill switch opening aligned to the back of the appliance, take hold of the adapter base and push the crimped edge into the appliance flue collar.
- F. Connect the upper wire terminals to the spill switch.
- G. Disconnect the wire leads to on/off switch, see "WIRING DIAGRAM" section and reconnect to the ends of the spill switch wires. Leave all excess wire in an orderly manner.

For aesthetics, the adapter has been designed to accept a standard matte black 7" appliance pipe and the Napoleon® decorative brass band (standard with the GS-150KT). Both are available from your local authorized dealer / distributor.

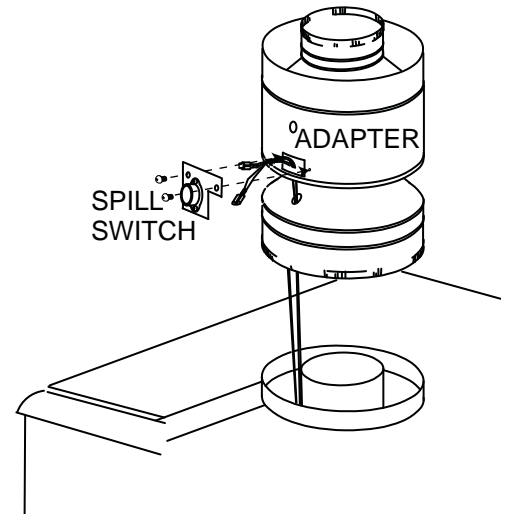
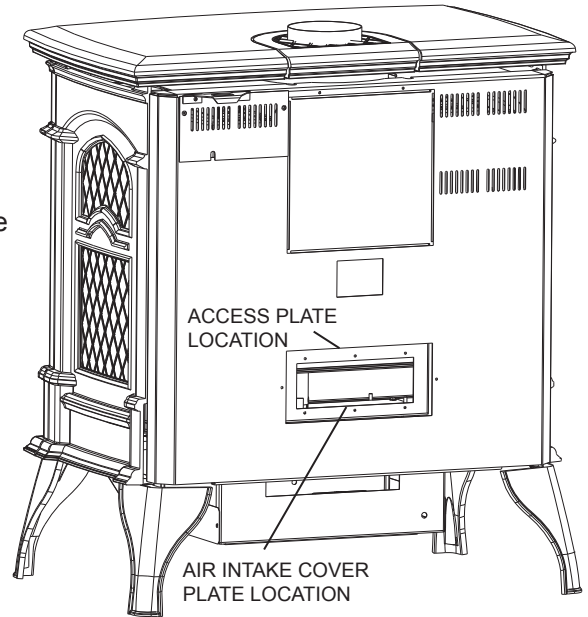

5.7.3 B-VENT

Attach the B-Vent label, shown, in the control area of the appliance.

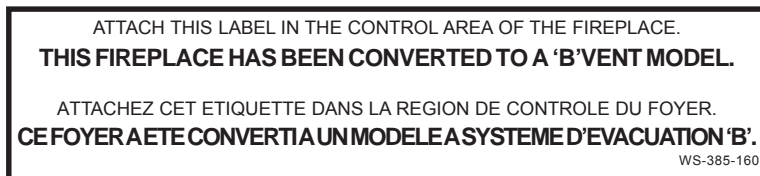

5.7.4 COMBUSTION AIR

This appliance needs air for safe operation and must be installed in such a way that adequate combustion air is available.

5.7.5 ADDING VENT SECTIONS

Add chimney sections, according to the manufacturers installation instructions. The chimney must extend at least, 3 feet above its point of contact with the roof and at least 2 feet higher than any wall, roof, building or obstacle within 10 feet horizontally.

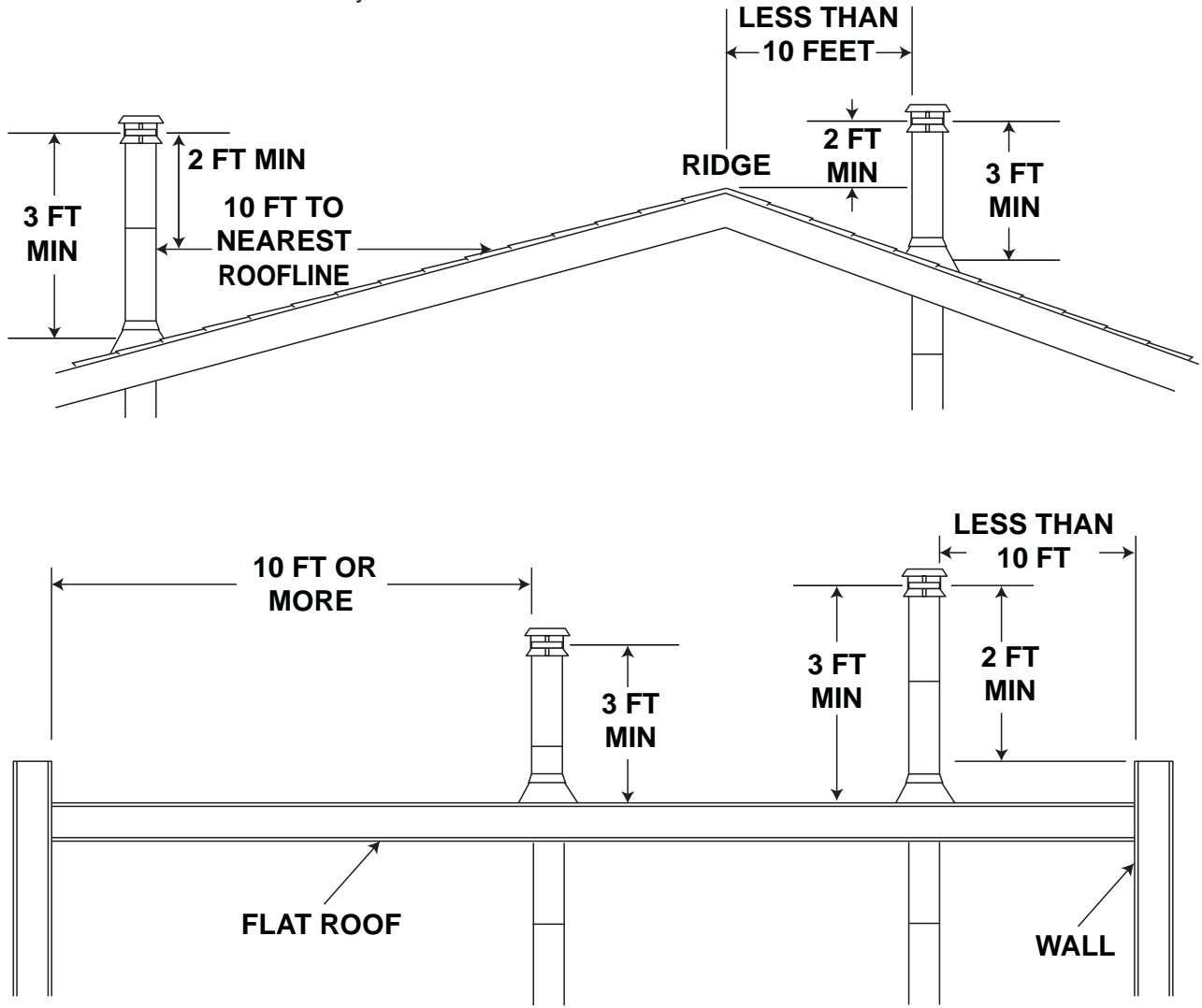

59.1A

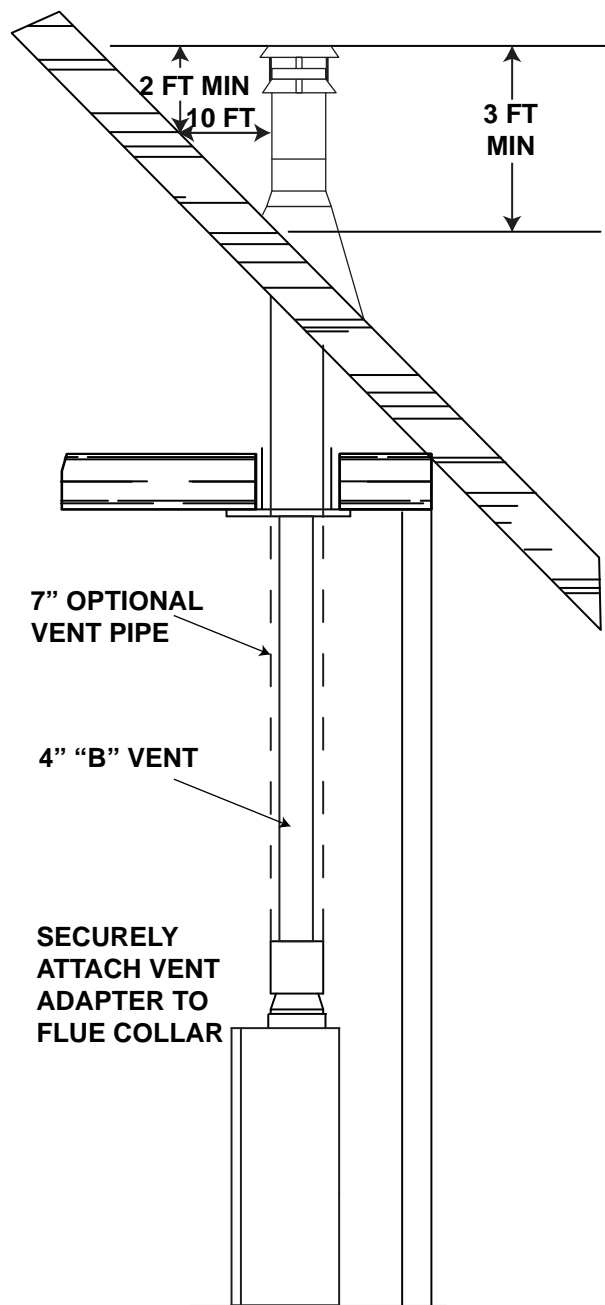

5.7.6 INSTALLING FLASHING AND STORM COLLAR

Remove the nails from the shingles above and to the sides of the chimney. Place the flashing over the chimney pipe and slide underneath the sides and upper edge of the shingles. Ensure that the chimney pipe is properly centered within the flashing, giving a 3/4" margin all around. Fasten to the roof on the top and sides. **DO NOT NAIL** through the lower portion of the flashing. Make weather-tight by sealing with caulking. Where possible, cover the sides and top edges of the flashing with roofing material. Apply waterproof caulking, provided with the flashing, around the chimney, 1" above the top of the flashing and push the storm collar down into the caulking. Insert a rain cap onto the top of the last chimney section.

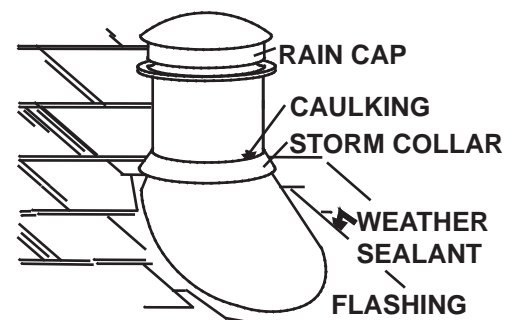

6.0 FINISHING

6.1 FRONT CAST REMOVAL

- A. Lift the top casting off the unit.
- B. Loosen the securing bolts on the cast front (located at either side on the top). Lift up and out.
- C. To install the front, repeat in reverse order.

6.2 GLASS DOOR INSTALLATION AND REMOVAL

When installing the glass door, a simple procedure must be followed in order to not damage the door.

- A. Lift the top casting off.
- B. Lift the cast front out of its retainers (located at either side on the top).
- C. Open the valve control cover. Pull the latch handles forward to release. The door may now be safely removed by swinging the bottom out and lifting it off. To install the door, repeat in reverse order.

The return flange must fit over the top of the ridge so that it rests on top of the firebox.

The 'T' latch portion is threaded and can be loosened or tightened to adjust for an effective door seal. Care must be taken when re-installing the door to ensure that the gasket at the top of the door does not bunch.

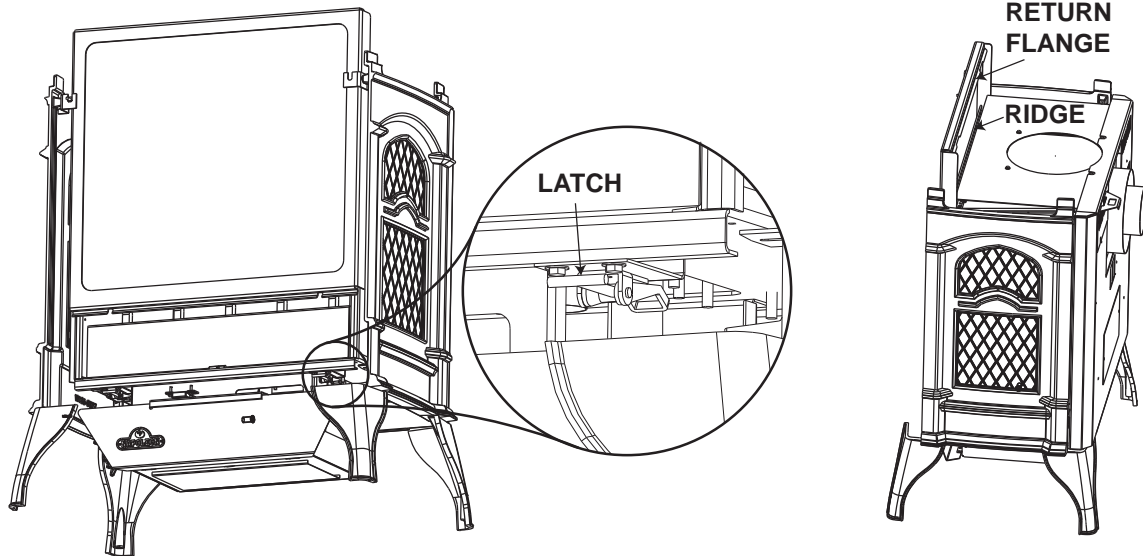

6.3 GLASS / DOOR REPLACEMENT

! WARNING
DO NOT USE SUBSTITUTE MATERIALS.
GLASS MAY BE HOT, DO NOT TOUCH GLASS UNTIL COOLED.
CARE MUST BE TAKEN WHEN REMOVING AND DISPOSING OF ANY BROKEN DOOR GLASS OR DAMAGED COMPONENTS. BE SURE TO VACUUM UP ANY BROKEN GLASS FROM INSIDE THE APPLIANCE BEFORE OPERATION.
DO NOT STRIKE, SLAM OR SCRATCH GLASS. DO NOT OPERATE APPLIANCE WITH GLASS REMOVED, CRACKED, BROKEN OR SCRATCHED.

- A. Place the door frame face down careful not to scratch the paint.
- B. Center the gasketed glass inside the door frame with the thick side of the gasket facing up.
- C. Bend the glass retainers located along the edge of the door frame over the gasket holding the glass in place. Careful not to break the glass.

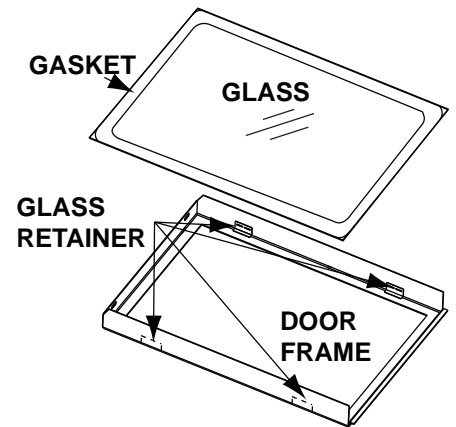

56.1

6.4 LOG PLACEMENT

Blocked burner ports can cause an incorrect flame pattern, carbon deposits and delayed ignition. Phazer™ logs glow when exposed to direct flame and provide a unique and realistic glowing effect. Use only certified phazer™ logs available from your Napoleon® dealer.

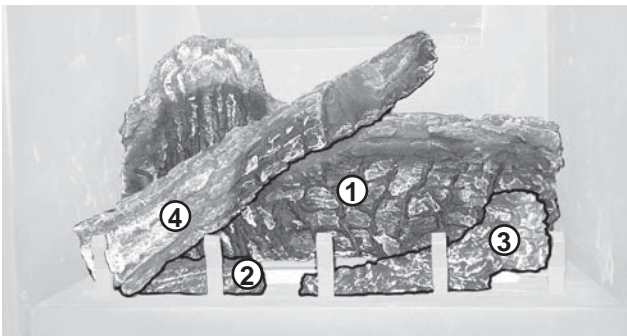

Place log #1 onto the burner, centering it onto the burner tray and pushing it as close to the rear wall of the firebox as possible. Move logs # 2 and 3 into position, lining up the studs located on the burner with the holes on the bottom of the logs. Sit the notch at the bottom of log #4 against the left outermost grate post and position the top of the log into the pocket provided on the rear log (#1).

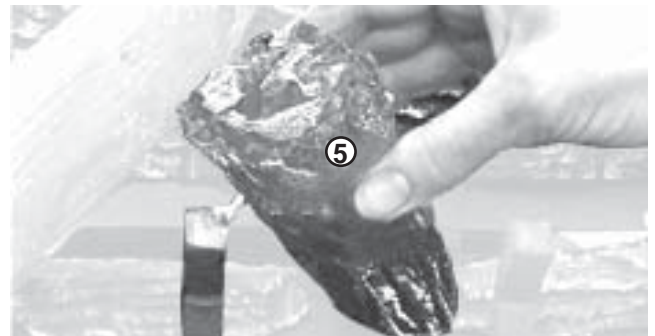

The notch in log #5 should be pressed down onto the skewering pin located at the end of the grate as shown to prevent it from rocking.

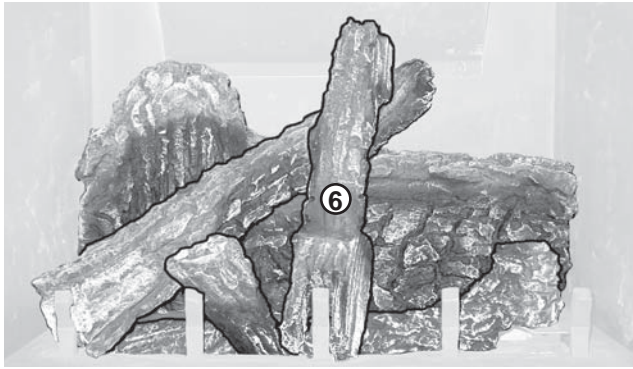

Position the notch located in log #6 against the grate post.

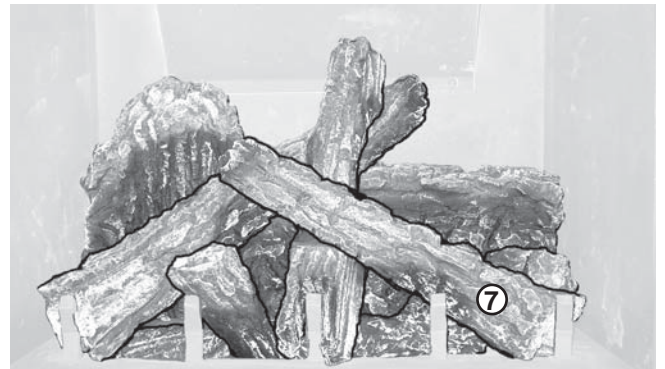

Place the bottom of log #7 against the right outermost grate post and the top into the pocket provided on the center log (#6). Bend up the tab in the log support to cradle log #7. Tear the glowing embers into pieces and place onto the front of the burner. Care should be taken to shred the embers into *thin, small irregular pieces* as only the exposed edges of the fibre hairs will glow when exposed to direct flame; however care should be taken to not block the burner ports. Blocked ports can cause an incorrect flame pattern, carbon deposits and delayed ignition.

Log colours may vary. During the initial use of the appliance, the colours will become more uniform as colour pigments burn in during the heat activated curing process.

POSITIONING THE LOGS IMPROPERLY WILL CAUSE FLAME IMPINGEMENT AND CARBONING.

6.5 LOGO PLACEMENT

Remove the backing of the logo supplied and centre over the logo installation holes,

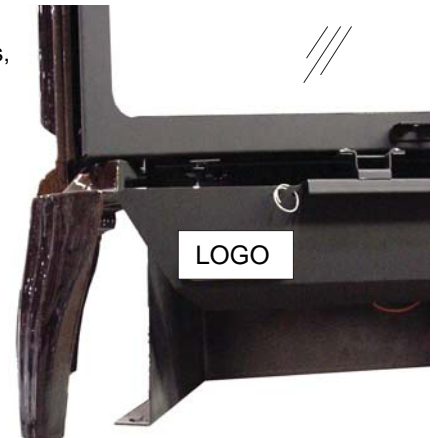

6.6 SWITCH AND BRACKET INSTALLATION

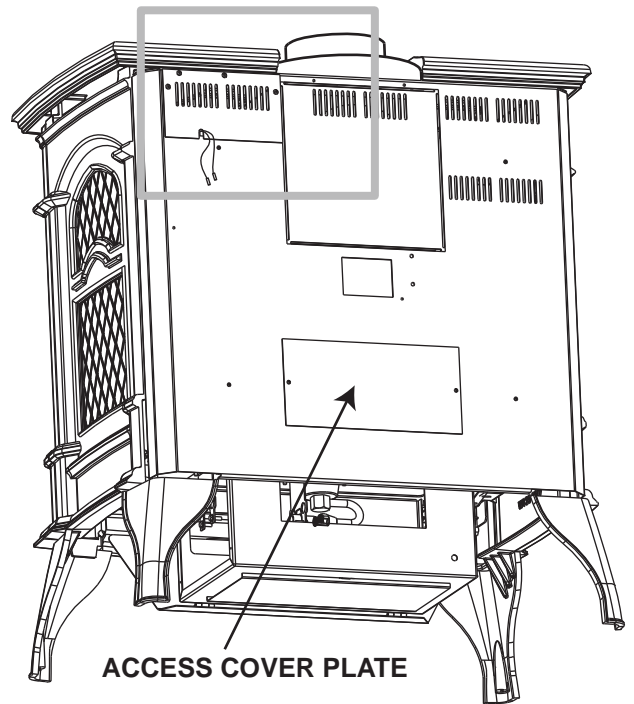
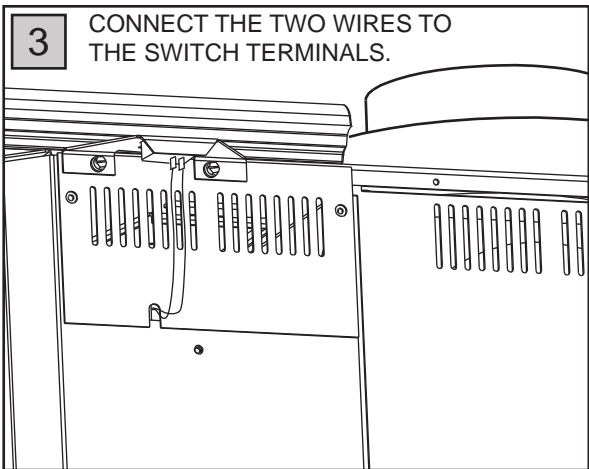
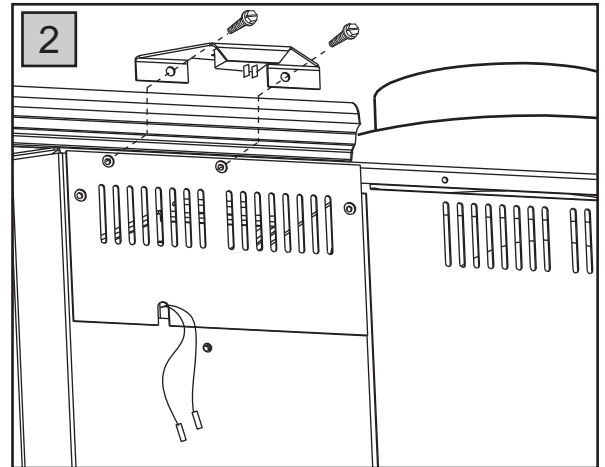
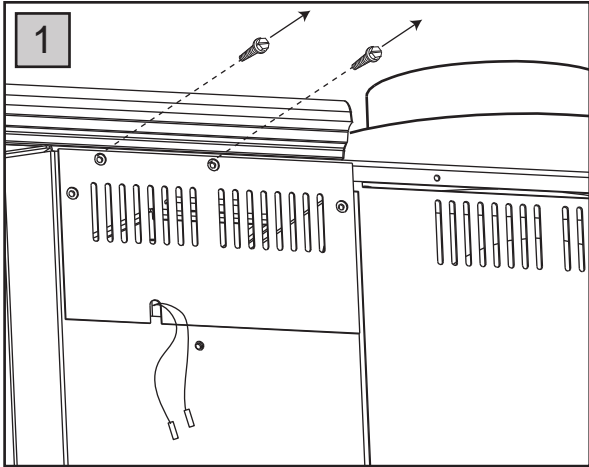

7.0 OPTIONAL BLOWER INSTALLATION

- A. Ensure that the access cover plate has been installed. For location, see "SWITCH AND BRACKET INSTALLATION" section.
- B. Remove the on/off switch bracket and the cover plate below it. The switch spacers and cover plate may now be discarded.
- C. Decide which side of the blower housing you prefer the on/off switch to be located on.
- D. Remove the top 2 screws from the left outer edge of the rear appliance panel.
- E. Mount and secure the blower housing using 4 screws (two of which were removed in previous step). Ensure that the on/off switch wires pass through the appropriate slot located on either side of the blower housing.

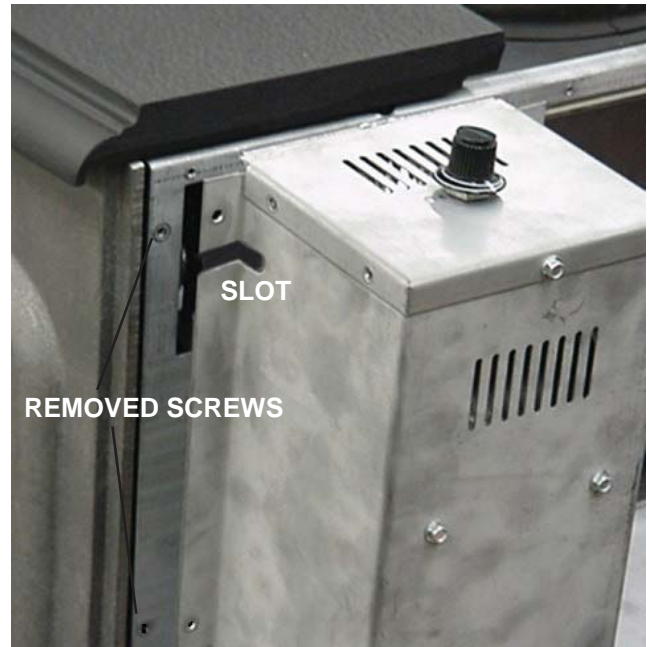

- F. Remove the 2 screws from the side of the blower housing that you want the switch to be located on and re-secure the on/off switch.

Because the blower is thermally activated, when turned on, it will automatically start approximately 15-30 minutes after lighting the appliance and will run for approximately 30-45 minutes after the appliance has been turned off. Use of the fan increases the output of heat.

Drywall dust will penetrate into blower bearings causing irreparable damage and must be prevented from coming into contact with the blower or its compartment.

Any damage resulting from this condition is not covered by the warranty policy.

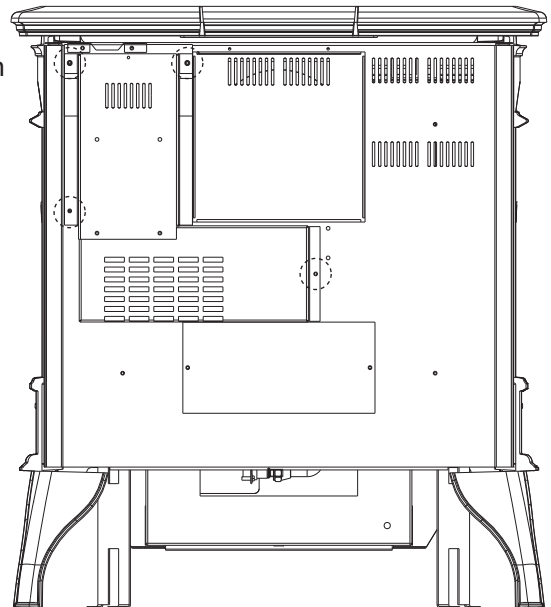

8.0 WIRING DIAGRAM

! WARNING
DO NOT WIRE 110 VOLTS TO THE VALVE OR WALL SWITCH.

This appliance comes equipped with a battery back-up. If this backup is used install four AA batteries (not supplied) into the holder and connect to the wire harness. Place near the IPI board. Connect the battery holder to the wire harness before using the appliance. Place near the IPI board. (Batteries not included). If backup is used, it must be connected to the 6 volt battery pack supplied.

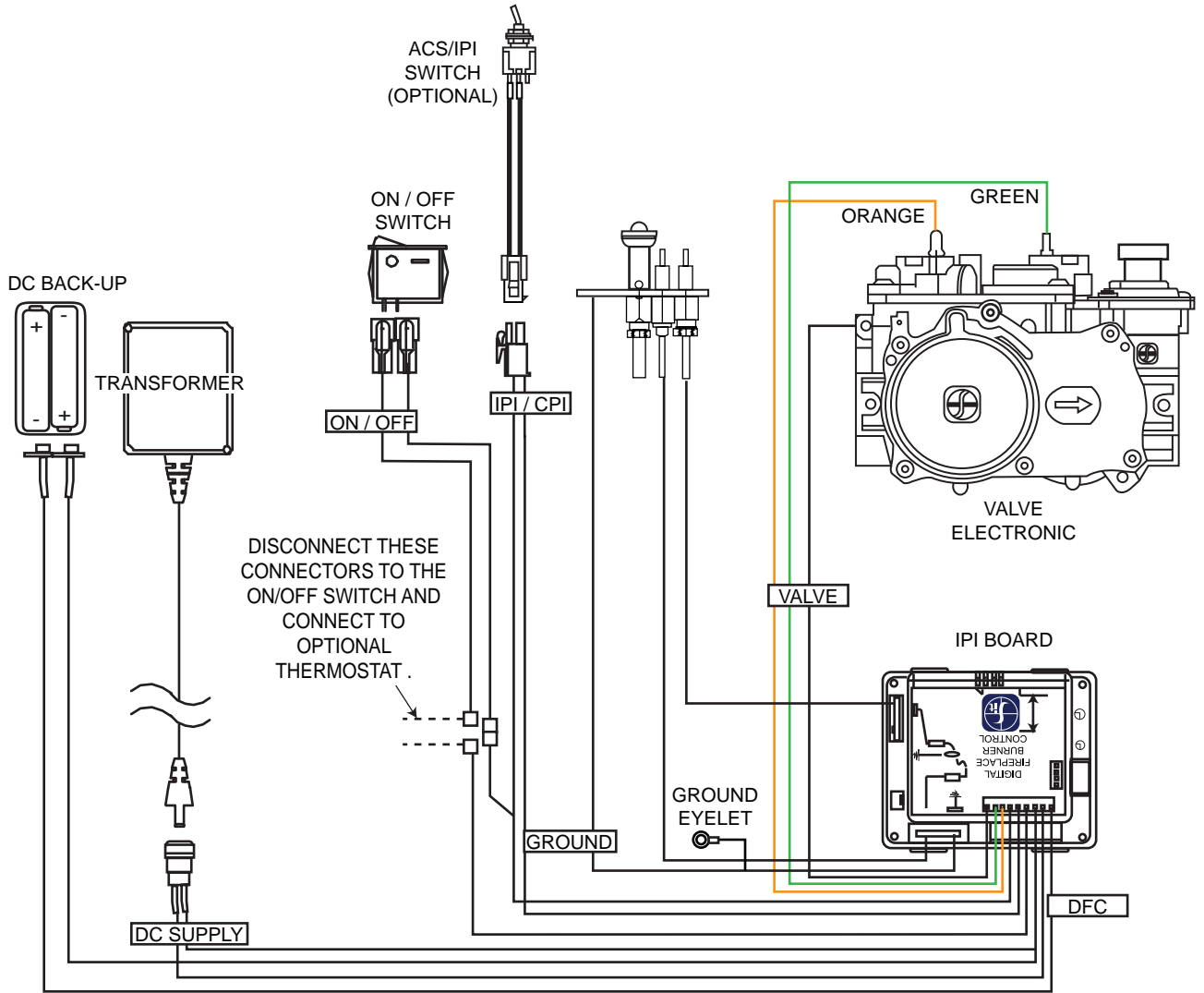

69.5

9.0 OPERATION

! WARNING
IF YOU DO NOT FOLLOW THESE INSTRUCTIONS EXACTLY, A FIRE OR EXPLOSION MAY RESULT CAUSING PROPERTY DAMAGE, PERSON INJURY OR LOSS OF LIFE.
ALWAYS LIGHT THE PILOT WHETHER FOR THE FIRST TIME OR IF THE GAS SUPPLY HAS RAN OUT WITH THE GLASS DOOR OPENED OR REMOVED.
TAMPERING WITH THE SPILL SWITCH CAN RESULT IN CARBON MONOXIDE (CO) POISONING AND POSSIBLE DEATH (GS60 ONLY).

MODEL GS60 ONLY: SPILL SWITCH

This is a thermally activated switch, attached to the back of the chimney adaptor, which senses the change in temperature and shuts down the gas valve in the event of a blocked or disconnected vent. It acts as a safety shut-off to prevent a build up of carbon monoxide or an explosion of unburned gases during start up. If the flue is blocked or has no "draw", the spill switch will automatically shut off the supply of gas within about 5-10 minutes.

MODEL GS60 ONLY: VENTING ACTION CHECK

A CHECK FOR CORRECT VENTING ACTION MUST BE MADE BEFORE THE INSTALLED APPLIANCE IS LEFT WITH THE CUSTOMER. Test in the following manner:

- A. Close all doors and windows in the room / start exhaust fans in the home / turn appliance blower off (if equipped).
- B. Set controls to "high" and light the unit.
- C. Wait 5 minutes. Light a match and extend it 1" into the hole located above the spill switch bracket on the adaptor.
- D. Venting action is satisfactory if the flame stays lit. Venting action is unsatisfactory if the flame extinguishes.
- E. If venting action is unsatisfactory, turn the unit off, wait 10 minutes and try again. If the match does not stay lit, turn the unit off and check for vent blockage or restriction. If necessary, consult with a qualified inspector.

9.1 OPERATING INSTRUCTIONS

The on-off switch is located on the back of the unit at the top left corner on models GDS60 and GS60.

NOTE: The upper firebox baffle of your new cast appliance has intentionally been left unpainted. Its shiny appearance will quickly transform to a dull black finish during the curing process.

When lit for the first time, the appliance will emit a slight odour for a few hours. This is a normal temporary condition caused by the "burn-in" of internal paints and lubricants used in the manufacturing process and will not occur again. Simply open a window to sufficiently ventilate the room. After extended periods of non-operation such as following a vacation or a warm weather season, the appliance may emit a slight odour for a few hours. This is caused by dust particles in the heat exchanger burning off. Open a window to sufficiently ventilate the room.

9.2 OPERATING INSTRUCTIONS - FOR YOUR SAFETY READ BEFORE OPERATING

OPERATING INSTRUCTIONS / INSTRUCTIONS D'OPERATION
FOR YOUR SAFETY READ BEFORE OPERATING / POUR VOTRE SÉCURITÉ LIRE AVANT DE FAIRE FONCTIONNER

WARNING: IF YOU DO NOT FOLLOW THESE INSTRUCTIONS EXACTLY, A FIRE OR EXPLOSION MAY RESULT CAUSING PROPERTY DAMAGE, PERSONAL INJURY OR LOSS OF LIFE.
 INITIAL LIGHTING OF THE PILOT AND MAIN BURNERS MUST BE DONE WITH THE GLASS DOOR OFF. DO NOT CONNECT VALVE OR WALL SWITCH TO ELECTRICITY. SEE INSTALLATION INSTRUCTIONS.

A. THIS FIREPLACE IS EQUIPPED WITH AN IGNITION DEVICE WHICH AUTOMATICALLY LIGHTS THE PILOT. DO NOT TRY TO LIGHT BY HAND.
 B. BEFORE OPERATING SMELL ALL AROUND THE FIREPLACE AREA FOR GAS AND NEXT TO THE FLOOR BECAUSE SOME GAS IS HEAVIER THAN AIR AND WILL SETTLE ON THE FLOOR.
WHAT TO DO IF YOU SMELL GAS:
 • TURN OFF ALL GAS TO THE FIREPLACE.
 • OPEN WINDOWS.
 • DO NOT TRY TO LIGHT ANY APPLIANCE.
 • DO NOT TOUCH ANY ELECTRIC SWITCH; DO NOT USE ANY PHONE IN YOUR BUILDING.
 • IMMEDIATELY CALL YOUR GAS SUPPLIER FROM A NEIGHBOUR'S PHONE. FOLLOW THE GAS SUPPLIER'S INSTRUCTIONS.
 • IF YOU CANNOT REACH YOUR GAS SUPPLIER, CALL THE FIRE DEPARTMENT.
 C. DO NOT TRY TO REPAIR ANY PART OF THIS ASSEMBLY. CALL A QUALIFIED SERVICE TECHNICIAN. FORCE OR ATTEMPTED REPAIR MAY RESULT IN A FIRE OR EXPLOSION.
 D. DO NOT USE THIS FIREPLACE IF ANY PART HAS BEEN UNDER WATER. IMMEDIATELY CALL A QUALIFIED SERVICE TECHNICIAN TO INSPECT THE FIREPLACE AND REPLACE ANY PART OF THE CONTROL SYSTEM AND ANY GAS CONTROL WHICH HAS BEEN UNDER WATER.

ATTENTION: SI CES INSTRUCTIONS NE SONT PAS OBSERVÉES A LA LETTRE, UN FEU OU UNE EXPLOSION POURRAIT S'ENSUIVRE CAUSANT DES DOMMAGES A LA PROPRIÉTÉ, DES BLESSURES CORPORELLES OU PERTE DE VIE.
 L'ALLUMAGE INITIAL DE LA VEILLEUSE ET DU BRÛLEUR PRINCIPAL DOIT SE FAIRE AVEC LA PORTE ENLEVÉE. NE RACCORDEZ PAS LA SOUPEAU OU L'INTERRUPTEUR MURALE L'ÉLECTRICITÉ. CONSULTEZ LES INSTRUCTIONS D'INSTALLATION.

A. CET APPAREIL EST MUNI D'UN DISPOSITIF D'ALLUMAGE QUI ALLUME LA VEILLEUSE AUTOMATIQUÉMENT.
 N'ESSAYEZ PAS D'ALLUMER LA VEILLEUSE MANUELLEMENT.
 B. AVANT D'ALLUMER SENTEZ L'AIR AUTOUR DE L'APPAREIL ET PRÈS DU PLANCHER (CERTAINS GAZ SONT PLUS LOURDS QUE L'AIR ET SE DÉPOSERONT AU NIVEAU DU PLANCHER) POUR DÉTECTER UNE FUITE POSSIBLE.
 QUE FAIRE SI VOUS DÉTECTEZ UNE ODEUR DE GAZ:
 • COUPEZ L'ALIMENTATION DE GAZ PRINCIPALE.
 • OUVREZ LES FENÊTRES.
 • N'ALLUMEZ AUCUN APPAREIL.
 • NE TOUCHEZ PAS À AUCUN INTERRUPTEUR ÉLECTRIQUE; N'UTILISEZ AUCUN TÉLÉPHONE DANS VOTRE IMMEUBLE.
 • APPELÉZ IMMÉDIATEMENT VOTRE FOURNISSEUR DE GAZ D'UN TÉLÉPHONE VOISIN ET SUIVEZ SES INSTRUCTIONS.
 • SI VOUS NE POUVEZ PAS REJOINDRE VOTRE FOURNISSEUR DE GAZ, APPELÉZ LE SERVICE DES INCENDIES.
 C. N'ESSAYEZ PAS DE RÉPARER AUCUNE PIÈCE DE CET ASSEMBLAGE. APPELÉZ UN TECHNICIEN QUALIFIÉ. FORCER OU TENTER DE RÉPARER L'ASSEMBLAGE POURRAIT CAUSER UN FEU OU UNE EXPLOSION.
 D. N'UTILISEZ PAS CET APPAREIL SI UN DE SES COMPOSANTS A ÉTÉ SUBMÉRGÉ. CONTACTEZ IMMÉDIATEMENT UN TECHNICIEN DE SERVICE QUALIFIÉ POUR INSPECTER L'APPAREIL ET REMPLACER TOUT SYSTÈME DE CONTRÔLE DE GAZ TOUCHÉ PAR L'EAU.

W385-0460

9.3 LIGHTING INSTRUCTIONS

LIGHTING INSTRUCTIONS / INSTRUCTIONS D'ALLUMAGE

- STOP!** READ ALL INFORMATION OF OPERATING AND LIGHTING INSTRUCTIONS BEFORE PROCEEDING.
- TURN OFF ELECTRIC POWER TO THE FIREPLACE.
- THIS FIREPLACE IS EQUIPPED WITH AN IGNITION DEVICE WHICH AUTOMATICALLY LIGHTS THE PILOT. DO NOT TRY TO LIGHT THE PILOT BY HAND.
- OPEN THE GLASS DOOR.
- TURN MANUAL SHUTOFF VALVE CLOCKWISE TO OFF.
- WAIT FIVE (5) MINUTES TO CLEAR OUT ANY GAS. IF YOU SMELL GAS INCLUDING NEAR THE FLOOR, **STOP!** FOLLOW "B" OF THE OPERATING INSTRUCTIONS. IF YOU DON'T SMELL GAS GO TO THE NEXT STEP.
- TURN MANUAL SHUTOFF VALVE COUNTER-CLOCKWISE TO ON.
- CLOSE THE GLASS DOOR.
- TURN ON ALL ELECTRIC POWER TO THE FIREPLACE.
- TURN ON MAIN BURNER.

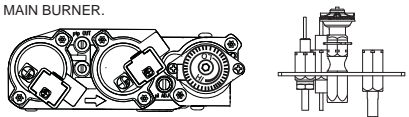

- ARRÊTEZ!** LISEZ TOUTES LES INSTRUCTIONS DE FONCTIONNEMENT ET D'ALLUMAGE AVANT DE CONTINUER.
- COUPEZ L'ALIMENTATION ÉLECTRIQUE À L'APPAREIL.
- CET APPAREIL EST MUNI D'UN DISPOSITIF D'ALLUMAGE QUI ALLUME LA VEILLEUSE AUTOMATIQUÉMENT, N'ESSAYEZ PAS D'ALLUMER LA VEILLEUSE MANUELLEMENT.
- OUVREZ LA PORTE VITRÉE.
- TOURNEZ LA SOUPEAU DE SECTIONNEMENT MANUELLE VERS LA DROITE À "OFF".
- ATTENDEZ CINQ (5) MINUTES POUR QUE LE GAZ PUISSE S'ÉCHAPPER. SI VOUS DÉTECTEZ UNE ODEUR DE GAZ, **ARRÊTEZ!** SUIVEZ « B » DANS LES INSTRUCTIONS DE FONCTIONNEMENT. S'IL N'Y A PAS D'ODEUR DE GAZ, PASSEZ À L'ÉTAPE SUIVANTE.
- TOURNEZ LA SOUPEAU DE SECTIONNEMENT MANUELLE VERS LA GAUCHE À "ON".
- FERMEZ LA PORTE VITRÉE.
- RÉTABLISSEZ L'ALIMENTATION ÉLECTRIQUE AU FOYER.
- ALLUMEZ LE BRÛLEUR PRINCIPAL.

TO TURN OFF GAS / INSTRUCTIONS POUR COUPER LE GAZ

- TURN OFF ALL ELECTRICAL POWER TO THE FIREPLACE IF SERVICE IS TO BE PERFORMED.
- TURN MANUAL SHUTOFF VALVE CLOCKWISE TO OFF. DO NOT FORCE.

- COUPEZ L'ALIMENTATION ÉLECTRIQUE AU FOYER SI UN TRAVAIL D'ENTRETIEN DOIT SE FAIRE.
- TOURNEZ LA SOUPEAU D'ARRÊT MANUELLE VERS LA DROITE À "OFF" NE FORCEZ PAS.

9.4 ANTI CONDENSATION SWITCH

This appliance has the option to go from an electronic intermittent pilot ignition (IPI) to a standing pilot (ACS) for cold climates. The anti condensation control switch (standing pilot) is located in the center of the control panel. Using your finger, flip the switch up for standing pilot, or down for intermittent pilot ignition.

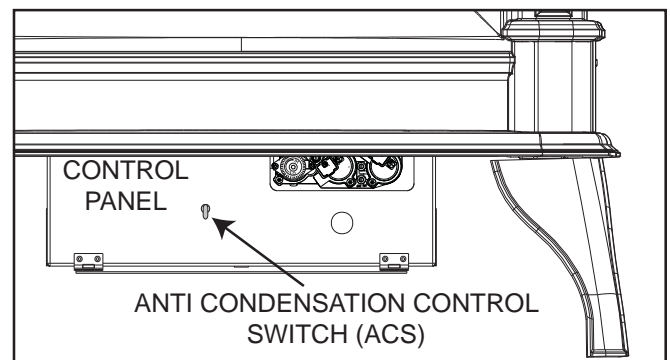

10.0 ADJUSTMENT

10.1 PILOT BURNER ADJUSTMENT

Adjust the pilot screw to provide properly sized flame. Turn in a clockwise direction to reduce the gas flow.

Check Pressure Readings:

Inlet pressure can be checked by turning screw (A) counter-clockwise 2 or 3 turns and then placing pressure gauge tubing over the test point. Gauge should read 7" (minimum 4.5") water column for natural gas or 13" (11" minimum) water column for propane. Check that main burner is operating on "HI".

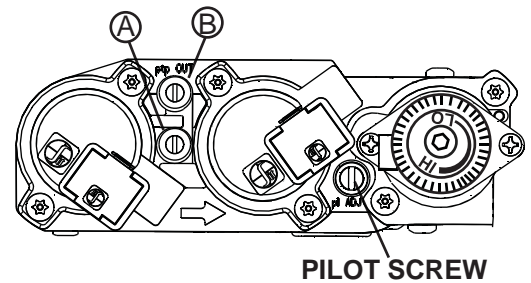

Outlet pressure can be checked the same as above using screw (B). Gauge should read 3.5" water column for natural gas or 10" water column for propane. Check that main burner is operating on "HI".

AFTER TAKING PRESSURE READINGS, BE SURE TO TURN SCREWS CLOCKWISE FIRMLY TO RESEAL. DO NOT OVERTORQUE.

Leak test with a soap and water solution.

39.4

10.2 VENTURI ADJUSTMENT

This appliance has an air shutter that has been factory set open according to the chart below:

Regardless of venturi orientation, closing the air shutter will cause a more yellow flame, but can lead to carboning. Opening the air shutter will cause a more blue flame, but can cause flame lifting from the burner ports. The flame may not appear yellow immediately; allow 15 to 30 minutes for the final flame color to be established.

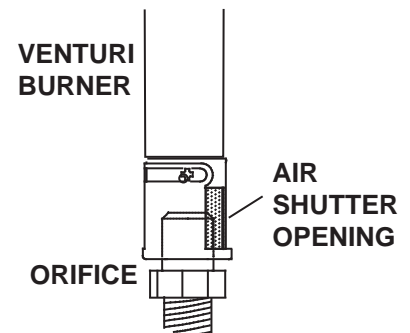

49.1

AIR SHUTTER ADJUSTMENT MUST ONLY BE DONE BY A QUALIFIED INSTALLER!

GDS60	
NG	3/8"
LP	5/16"

10.3 FLAME CHARACTERISTICS

It's important to periodically perform a visual check of the pilot and burner flames. Compare them to the illustrations provided. If any flames appear abnormal call a service person.

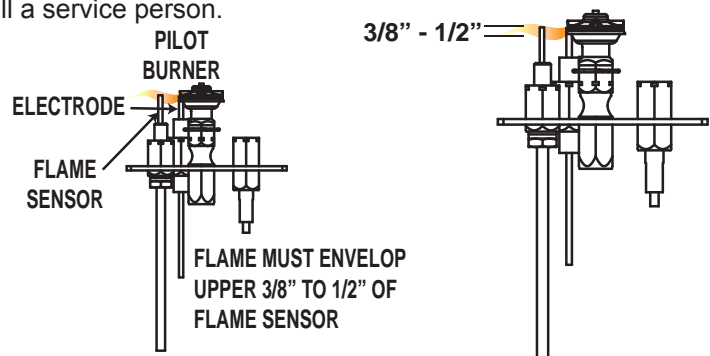
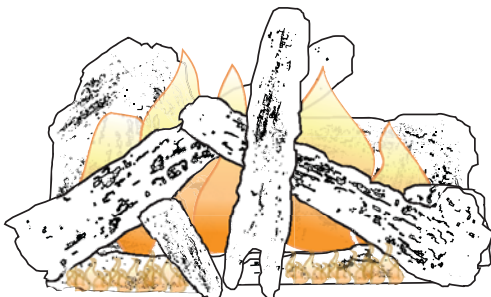

54.1

10.4 RESTRICTING VERTICAL VENTS - MODEL GDS60

Vertical installations may display a very active flame. If this appearance is not desirable, the vent exit must be restricted using the restrictor vent kit, GDSRP-KT. This will reduce the velocity of the exhaust gases, slowing down the flame pattern and creating a more traditional gentle appearance. Specific instructions are included with the kit.

11.0 MAINTENANCE

! WARNING
TURN OFF THE GAS AND ELECTRICAL POWER BEFORE SERVICING THE APPLIANCE.
APPLIANCE MAY BE HOT, DO NOT SERVICE UNTIL APPLIANCE HAS COOLED.
DO NOT USE ABRASIVE CLEANERS.

CAUTION: Label all wires prior to disconnection when servicing controls. Wiring errors can cause improper and dangerous operation. Verify proper operation after servicing. This appliance and its venting system should be inspected before use and at least annually by a qualified service person. The appliance area must be kept clear and free of combustible materials, gasoline or other flammable vapors and liquids. The flow of combustion and ventilation air must not be obstructed.

1. In order to properly clean the burner and pilot assembly, remove the logs, rocks and/or glass to expose both assemblies.
2. Keep the control compartment, media, burner, air shutter opening and the area surrounding the logs clean by vacuuming or brushing, at least once a year.
3. Check to see that all burner ports are burning. Clean out any of the ports which may not be burning or are not burning properly.
4. Check to see that the pilot flame is large enough to engulf the flame sensor and/or thermocouple / thermopile as well as reaches the burner.
5. Replace the cleaned logs, rocks or glass. Failure to properly position the media may cause carboning which can be distributed in the surrounding living area.
6. Check to see that the main burner ignites completely on all openings when turned on. A 5 to 10 second total light-up period is satisfactory. If ignition takes longer, consult your local authorized dealer / distributor.
7. Check that the gasketing on the sides, top and bottom of the door is not broken or missing. Replace if necessary.
8. If for any reason the vent air intake system is disassembled, re-install and re-seal per the instructions provided for the initial installation.

40.1

11.1 CARE OF GLASS

DO NOT CLEAN GLASS WHEN HOT! DO NOT USE ABRASIVE CLEANERS TO CLEAN GLASS.

Buff lightly with a clean dry soft cloth. Clean both sides of the glass after the first 10 hours of operation with a recommended fireplace glass cleaner. Thereafter clean as required. If the glass is not kept clean permanent discoloration and / or blemishes may result.

! WARNING	
	<p>HOT GLASS WILL CAUSE BURNS.</p> <p>DO NOT TOUCH GLASS UNTIL COOLED.</p> <p>NEVER ALLOW CHILDREN TO TOUCH GLASS.</p>

5.1

12.0 REPLACEMENTS

Contact your dealer or the factory for questions concerning prices and policies on replacement parts. Normally all parts can be ordered through your Authorized dealer / distributor.

FOR WARRANTY REPLACEMENT PARTS, A PHOTOCOPY OF THE ORIGINAL INVOICE WILL BE REQUIRED TO HONOUR THE CLAIM.

When ordering replacement parts always give the following information:

- Model & Serial Number of appliance
- Installation date of appliance
- Part number
- Description of part
- Finish

*** IDENTIFIES ITEMS WHICH ARE NOT ILLUSTRATED. FOR FURTHER INFORMATION, CONTACT YOUR AUTHORIZED DEALER.**

! WARNING

FAILURE TO POSITION THE PARTS IN ACCORDANCE WITH THIS MANUAL OR FAILURE TO USE ONLY PARTS SPECIFICALLY APPROVED WITH THIS APPLIANCE MAY RESULT IN PROPERTY DAMAGE OR PERSONAL INJURY.

41.1

COMMON COMPONENTS		
REF NO.	PART NO.	DESCRIPTION
1	W135-0209	LOG #1
2	W135-0082	CHARCOAL PIECE (LOG #2)
3	W135-0182	LOG #3
4	W135-0210	LOG #4
5	W135-0211	LOG #5
6	W135-0212	LOG #6
7	W135-0213	LOG #7
8	GL-646	LOG SET
9	W725-0062	SIT VALVE - NG
9	W725-0063	SIT VALVE - LP
10	W010-0624	BURNER
11	W456-0035	#35 BURNER ORIFICE - NG
11	W456-0053	#53 BURNER ORIFICE - LP
11	W456-0045	#45 BURNER ORIFICE - NG
11	W456-0055	#55 BURNER ORIFICE - LP
12	W010-1865	PILOT ASSEMBLY - NG
12	W010-1866	PILOT ASSEMBLY - LP
13	W455-0069	PILOT INJECTOR - NG
13	W455-0068	PILOT INJECTOR - LP
14*	W190-0029	IPI BOARD
15*	W707-0010	TRANSFORMER
16*	W361-0016	GLOWING EMBERS
17*	W550-0001	CHARCOAL EMBERS
19*	W385-0334	NAPOLEON® LOGO
20	W390-0001	LATCH
21*	W660-0009	ON/OFF SWITCH
22*	W690-0002	THERMODISC
23*	W380-0002	VARIABLE SPEED SWITCH KNOB
24	KB-35	VARIABLE SPEED SWITCH
25	GZ-552	REPLACEMENT BLOWER

COMMON COMPONENTS		
REF NO.	PART NO.	DESCRIPTION
26	W135-0377**	SIDE (LEFT OR RIGHT)
27	W135-0375**	TOP
28	W135-0376**	FRONT
29*	W010-0648	GLASS WITH GASKET
30*	W190-0029	CONTROL MODULE - EI

**FOR OTHER AVAILABLE COLOURS, ADD THESE LETTERS TO THE BASE PART NUMBER:

COLOR	LETTER	FINISH
MAJOLICA BROWN	N	PORCELAIN

GS60 COMPONENTS		
REF NO.	PART NO.	DESCRIPTION
31	W010-0459	ADAPTOR C/W SPILL SWITCH
32	W660-0006	SPILL SWITCH
33	W080-0405	SPILL SWITCH BRACKET

TERMINAL KITS		
REF NO.	PART NO.	DESCRIPTION
GD-175		WALL TERMINAL KIT
34	BM6790	90° ELBOW - 7" DIAMETER
35	GD-222	TERMINAL ASSEMBLY
36	BM67ADJ	30" TO 53" ADJUSTABLE PIPE - 7" DIA
37	W010-1313	FIRESTOP SPACER
38*	W585-0267	TOP VENT SHIELD
39*	W020-0032	HARDWARE
40	BM3730	BLACK TRIM COLLAR
41	BM6724	24" STOVE PIPE - 7" DIAMETER
42*	W010-0300	10' ALUMINUM FLEX LINER C/W SPACERS - 4" DIA
43*	W025-0003	DECORATIVE BLACK BAND
GD-180		PERISCOPE TERMINAL KIT
34	BM6790	90° ELBOW - 7" DIAMETER
36	BM67ADJ	30" TO 53" ADJUSTABLE PIPE - 7" DIA
37	W010-1313	FIRESTOP SPACER
38*	W585-0267	TOP VENT SHIELD
39*	W020-0032	HARDWARE
40	BM3730	BLACK TRIM COLLAR
41	BM6724	24" STOVE PIPE - 7" DIAMETER
42*	W010-0300	10' ALUMINUM FLEX LINER C/W SPACERS - 4" DIA
43	W025-0003	DECORATIVE BLACK BAND
44	GD-201	PERISCOPE

ROOF TERMINAL KITS			
REF NO.	PART NO.	DESCRIPTION	
GD-110		1/12 TO 7/12 PITCH	
45	W670-0006	4/7 TERMINAL	
46	W490-0073	4/7 INNER/OUTER SLEEVE	
47	W010-0567	ROOF SUPPORT	
48	W170-0063	STORM COLLAR	
49	W263-0054	ROOF FLASHING	
GD-111		8/12 TO 12/12 PITCH	
45	W670-0006	4/7 TERMINAL	
46	W490-0073	4/7 INNER/OUTER SLEEVE	
47	W010-0567	ROOF SUPPORT	
48	W170-0063	STORM COLLAR	
50	W263-0055	ROOF FLASHING	
GD-112		FLAT ROOF	
45	W670-0006	4/7 TERMINAL	
46	W490-0073	4/7 INNER/OUTER SLEEVE	
47	W010-0567	ROOF SUPPORT	
51	W263-0056	ROOF FLASHING	
48	W170-0063	STORM COLLAR	
ACCESSORIES			
REF NO.	GDS60-1	GS60	DESCRIPTION
18*	W573-0007	W573-0007	HIGH TEMPERATURE SEALANT
52*	W690-0001	W690-0001	MILLIVOLT THERMOSTAT
53*	F40	F40	ON/OFF REMOTE
54*	F50	F50	THERMOSTATIC REMOTE
55*	W562-0031	W562-0031	GLASS GASKET
56	GS831K	GS831K	BLACK TRIVET
57	GS831C	GS831C	CHROME TRIVET
58*	GDSLL-KT	GDSLL-KT	LEVELING / SECURING KIT
59	GS-64KT	GS-64KT	BLOWER KIT
60*	GDS819KT	GDS819KT	DECORATIVE BRICK PANEL
61*	W175-0318	W175-0318	CONVERSION KIT - NG-LP
62*	W175-0319	W175-0319	CONVERSION KIT - LP-NG
63*	BM6745	BM6745	45° ELBOW
64	GD-301	GD-301	HEAT GUARD
65*	W175-0001	_____	4" COUPLER
66*	GDSRP-KT	_____	RESTRICTOR KIT
67	_____	GS-150KT	ADAPTOR KIT

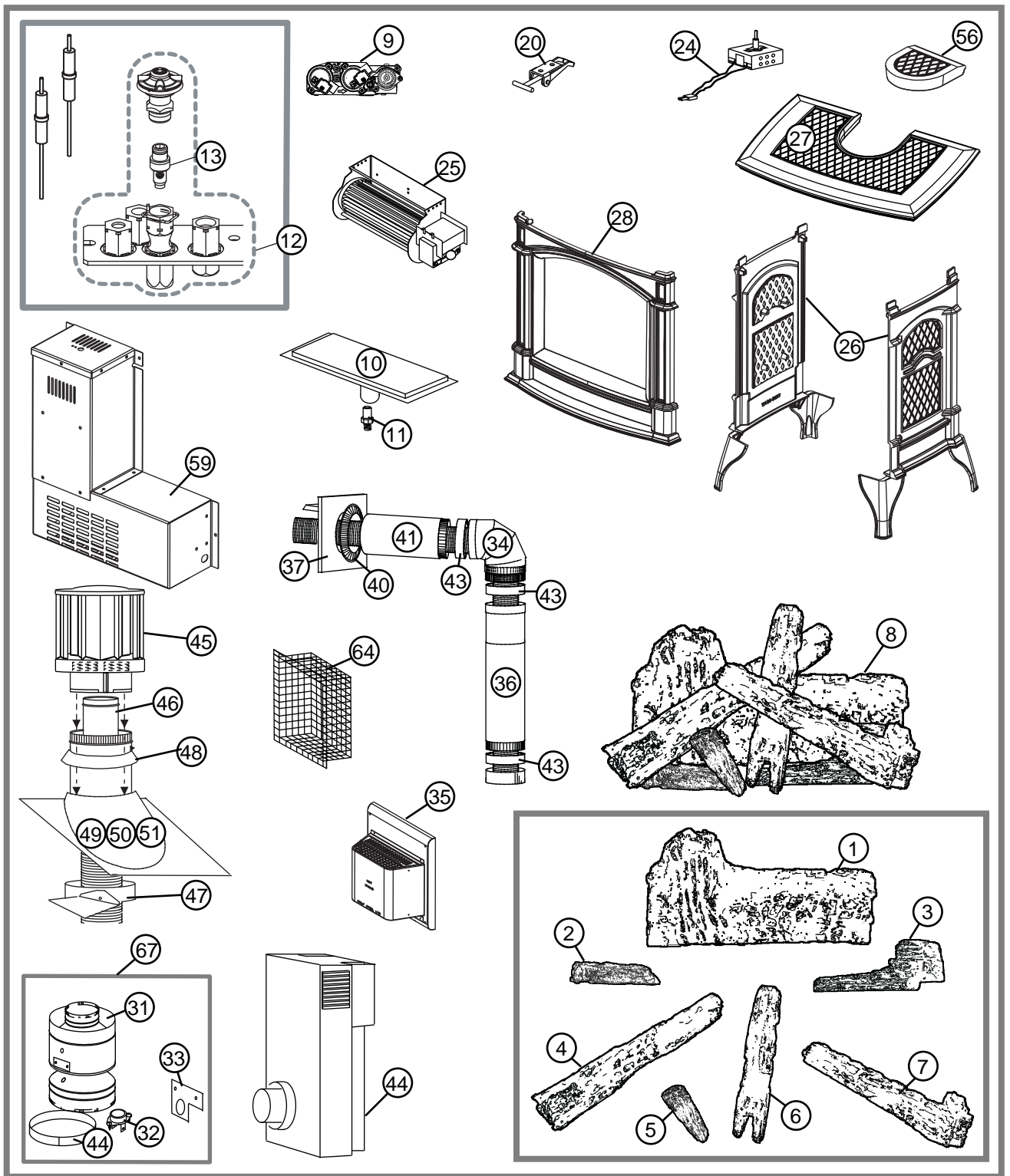

13.0 TROUBLE SHOOTING

! WARNING

ALWAYS LIGHT THE PILOT WHETHER FOR THE FIRST TIME OR IF THE GAS SUPPLY HAS RAN OUT, WITH THE GLASS DOOR OPEN OR REMOVED.

TURN OFF THE GAS AND ELECTRICAL POWER BEFORE SERVICING THE APPLIANCE.

APPLIANCE MAY BE HOT, DO NOT SERVICE UNTIL APPLIANCE HAS COOLED.

DO NOT USE ABRASIVE CLEANERS.

SYMPTOM	PROBLEM	TEST SOLUTION	
Pilot will not light. Makes noise with no spark at pilot burner.	Wiring.	- Verify the wire for the sensor and the wire for the ignitor are connected to the correct terminals (not reversed) on the module. NOTE: Sensor has 3/16" connection and ignitor has 1/8" connection.	
	Loose connection.	- Verify no loose connections, electrical shorts in the wiring or ground out to any metal object.	
	Module.	- Turn the ON/OFF switch to the "OFF" position. Remove the igniter wire from the module. Place the ON/OFF switch to the "ON" position. Hold a grounded wire about 3/16" away from the ignitor (spark) terminal on the module. If no spark the ignitor terminal module must be replaced. If there is a spark the ignitor terminal is fine. Inspect pilot assembly for a shorted wire or cracked insulator around the electrode.	
	Igniter Spark gap is incorrect.	- Spark gap of the ignitor to the pilot should be 1/8".	
	Transformer.	- Verify the transformer is installed and plugged into the module. Check voltage of the transformer under load at the spade connections on the module with the ON/OFF switch in the "ON" position. Acceptable readings of a good transformer are between 6.2 and 7.0 volts A.C.	
	Battery backup (if power is off)	- Check batteries.	
	A shorted or loose Connection.	- Remove and reinstall the wiring harness that plugs into the module. Remove and verify continuity of each wire in wiring harness.	
Igniter Spark gap is incorrect. Transformer. Battery backup (if power is off) A shorted or loose Connection. Improper switch wiring. Module is not grounded.	Improper switch wiring.	- Troubleshoot the system with the simplest ON/OFF switch.	
	Module is not grounded.	- Verify the valve and pilot assemblies are properly grounded to the metal chassis of the appliance or log set.	
	Pilot sparks but will not light.	Gas supply.	- Verify that the incoming gas line ball valve is "Open". Verify that the inlet pressure reading is within acceptable limits, inlet pressures must not exceed 14" W.C.
	Out of propane gas.	- Fill the tank.	

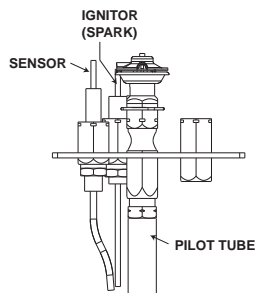

SYMPTOM	PROBLEM	TEST SOLUTION
Carbon is being deposited on glass, logs, rocks, media or combustion chamber surfaces.	Air shutter has become blocked.	- Ensure air shutter opening is free of lint or other obstructions.
	Flame is impinging on the glass, logs, rocks, media or combustion chamber.	<ul style="list-style-type: none"> - Check that the glass, logs, rocks or media are correctly positioned. - Open air shutter to increase the primary air. - Check the input rate: check the manifold pressure and orifice size as specified by the rating plate values. - Check that the door gasketing is not broken or missing and that the seal is tight. - Check that both vent liners are free of holes and well sealed at all joints. - Check that minimum rise per foot has been adhered to for any horizontal venting.
Continues to spark and pilot lights, but main burner will not light.	Short or loose connection in sensor rod.	- Verify all connections. Verify the connections from the pilot assembly are tight; also verify these connections are not grounding out to any metal.
	Poor flame rectification or contaminated sensor rod.	- Verify the flame is engulfing the sensor rod. This will increase the flame rectification. Verify correct pilot orifice is installed and inlet gas specifications to manual. (Remember, the flame carries the rectification current, not the gas. If the flame lifts from pilot hood, the circuit is broken. A wrong orifice or too high of an inlet pressure can cause the pilot flame to lift.) The sensor rod may need cleaning.
	Poor grounding between pilot assembly and gas valve.	- Verify that the wire harness is firmly connected to module. Verify that the ceramic insulator around the sensor rod is not cracked, damaged, or loose. Verify the connection from the sensor rod to the sensor wire.
	Damaged pilot or dirty sensor rod.	- Clean sensor rod with an emery cloth to remove any contamination that may have accumulated on the sensor rod. Verify continuity with multimeter with ohms set at the lowest range.
Pilot lights Stops sparking / pilot remains lit but burner will not turn on.	Wiring / Connection.	- Inspect all wires, ensure good tight connections. Verify that all wiring is installed exactly as specified.
	Wiring harness.	- Inspect the wiring harness, and verify the harness is tightly connected to the module. Verify that all wires are connected in the right order. See "WIRING DIAGRAM" section.
Exhaust fumes smelled in room, headaches.	Appliance is spilling.	<ul style="list-style-type: none"> - Check all seals. - Check if exhaust is re-entering through an open door or window.

42.7_2

SYMPTOM	PROBLEM	TEST SOLUTION
White / grey film forms.	Sulphur from fuel is being deposited on glass, logs or combustion chamber surfaces.	<ul style="list-style-type: none"> - Clean the glass, see "CARE OF GLASS" section - DO NOT CLEAN GLASS WHEN HOT. - If deposits are not cleaned off regularly, the glass may become permanently marked.
Flames are very aggressive. GDS60 ONLY	<ul style="list-style-type: none"> Door is ajar. Venting action is too great. 	<ul style="list-style-type: none"> - Tighten door clamps. - Restrict vent exit with restrictor plate. See "RESTRICTING VENTS" section.
Main burner flame is a blue, lazy, transparent flame.	<ul style="list-style-type: none"> Blockage in vent. Compromised venting. 	<ul style="list-style-type: none"> - Remove blockage. In really cold conditions, ice buildup may occur on the terminal and should be removed. - Check venting system parameters (seal, length, rise, etc.).
GDS60 ONLY	GLASS EMBERS ONLY: Too many glass embers.	<ul style="list-style-type: none"> - Re-distribute glass embers so that only a single layer is over top of the burner tube.
Main burner goes out: pilot goes out.	Vent recirculation.	<ul style="list-style-type: none"> - Check joint seals and installation.

42.7_3

Main burner and pilot cycles on and off. GS60 ONLY	Venting is spilling.	<ul style="list-style-type: none"> - Test with spill switch bypassed. Replace if defective. - Check for vent blockage.
--------------------------------------------------------------	----------------------	------------------------------------------------------------------------------------------------------------------------------------------------

14.0 WARRANTY

NAPOLEON® products are manufactured under the strict Standard of the world recognized ISO 9001 : 2008 Quality Assurance Certificate.

NAPOLEON® products are designed with superior components and materials assembled by trained craftsmen who take great pride in their work. The burner and valve assembly are leak and test-fired at a quality test station. The complete appliance is again thoroughly inspected by a qualified technician before packaging to ensure that you, the customer, receives the quality product that you expect from NAPOLEON®.

NAPOLEON® GAS APPLIANCE PRESIDENT'S LIFETIME LIMITED WARRANTY

The following materials and workmanship in your new NAPOLEON® gas appliance are warranted against defects for as long as you own the appliance. This covers: combustion chamber, heat exchanger, stainless steel burner, phazer™ logs and embers, rocks, ceramic glass (thermal breakage only), gold plated parts against tarnishing, porcelainized enameled components and aluminum extrusion trims.*

Electrical (110V and millivolt) components and wearable parts such as blowers, gas valves, thermal switch, switches, wiring, remote controls, ignitor, gasketing, and pilot assembly are covered and NAPOLEON® will provide replacement parts free of charge during the first year of the limited warranty.*

Labour related to warranty repair is covered free of charge during the first year. Repair work, however, requires the prior approval of an authorized company official. Labour costs to the account of NAPOLEON® are based on a predetermined rate schedule and any repair work must be done through an authorized NAPOLEON® dealer.

* Construction of models vary. Warranty applies only to components included with your specific appliance.

CONDITIONS AND LIMITATIONS

NAPOLEON® warrants its products against manufacturing defects to the original purchaser only. Registering your warranty is not necessary. Simply provide your proof of purchase along with the model and serial number to make a warranty claim. NAPOLEON® reserves the right to have its representative inspect any product or part thereof prior to honouring any warranty claim. Provided that the purchase was made through an authorized NAPOLEON® dealer your appliance is subject to the following conditions and limitations:

Warranty coverage begins on the date of original installation.

This factory warranty is non-transferable and may not be extended whatsoever by any of our representatives.

The gas appliance must be installed by a licensed, authorized service technician or contractor. Installation must be done in accordance with the installation instructions included with the product and all local and national building and fire codes.

This limited warranty does not cover damages caused by misuse, lack of maintenance, accident, alterations, abuse or neglect and parts installed from other manufacturers will nullify this warranty.

This limited warranty further does not cover any scratches, dents, corrosion or discoloring caused by excessive heat, abrasive and chemical cleaners nor chipping on porcelain enamel parts, mechanical breakage of PHAZER™ logs and embers.

This warranty extends to the repair or replacement of warranted parts which are defective in material or workmanship provided that the product has been operated in accordance with the operation instructions and under normal conditions.

After the first year, with respect to this President's Lifetime Limited Warranty, NAPOLEON® may, at its discretion, fully discharge all obligations with respect to this warranty by refunding to the original warranted purchaser the wholesale price of any warranted but defective part(s).

NAPOLEON® will not be responsible for installation, labour or any other expenses related to the reinstallation of a warranted part and such expenses are not covered by this warranty.

Notwithstanding any provisions contained in the President's Lifetime Limited Warranty, NAPOLEON'S responsibility under this warranty is defined as above and it shall not in any event extend to any incidental, consequential or indirect damages.

This warranty defines the obligations and liability of NAPOLEON® with respect to the NAPOLEON® gas appliance and any other warranties expressed or implied with respect to this product, its components or accessories are excluded.

NAPOLEON® neither assumes, nor authorizes any third party to assume, on its behalf, any other liabilities with respect to the sale of this product.

NAPOLEON® will not be responsible for: over-firing, downdrafts, spillage caused by environmental conditions such as rooftops, buildings, nearby trees, hills, mountains, inadequate vents or ventilation, excessive venting configurations, insufficient makeup air, or negative air pressures which may or may not be caused by mechanical systems such as exhaust fans, furnaces, clothes dryers, etc.

Any damages to the appliance, combustion chamber, heat exchanger, plated trim or other components due to water, weather damage, long periods of dampness, condensation, damaging chemicals or cleaners will not be the responsibility of NAPOLEON®.

All parts replaced under the President's Limited Lifetime Warranty Policy are subject to a single claim.

During the first 10 years NAPOLEON® will replace or repair the defective parts covered by the lifetime warranty at our discretion free of charge. From 10 years to life, NAPOLEON® will provide replacement parts at 50% of the current retail price.

All parts replaced under the warranty will be covered for a period of 90 days from the date of their installation.

The manufacturer may require that defective parts or products be returned or that digital pictures be provided to support the claim. Returned products are to be shipped prepaid to the manufacturer for investigation. If a product is found to be defective, the manufacturer will repair or replace such defect.

Before shipping your appliance or defective components, your dealer must obtain an authorization number. Any merchandise shipped without authorization will be refused and returned to sender.

Shipping costs are not covered under this warranty.

Additional service fees may apply if you are seeking warranty service from a dealer.

Warranty labour allowance is only for the replacement of the warranted part. Travel, diagnostic tests, shipping and other related charges are not covered by this warranty.

ALL SPECIFICATIONS AND DESIGNS ARE SUBJECT TO CHANGE WITHOUT PRIOR NOTICE DUE TO ON-GOING PRODUCT IMPROVEMENTS. NAPOLEON® IS A REGISTERED TRADEMARK OF WOLF STEEL LTD. PATENTS U.S. 5.303.693.801 - CAN. 2.073.411, 2.082.915. © WOLF STEEL LTD.

