

INSTALLER: LEAVE THIS MANUAL WITH THE APPLIANCE.
CONSUMER: RETAIN THIS MANUAL FOR FUTURE REFERENCE.



INSTALLATION AND OPERATING INSTRUCTIONS

CERTIFIED UNDER CANADIAN AND AMERICAN NATIONAL STANDARDS: CSA 2.33, ANSI Z21.88 FOR VENTED GAS FIREPLACE HEATERS.

THE MADISON™

GD80NT
NATURAL GAS

GD80PT
PROPANE

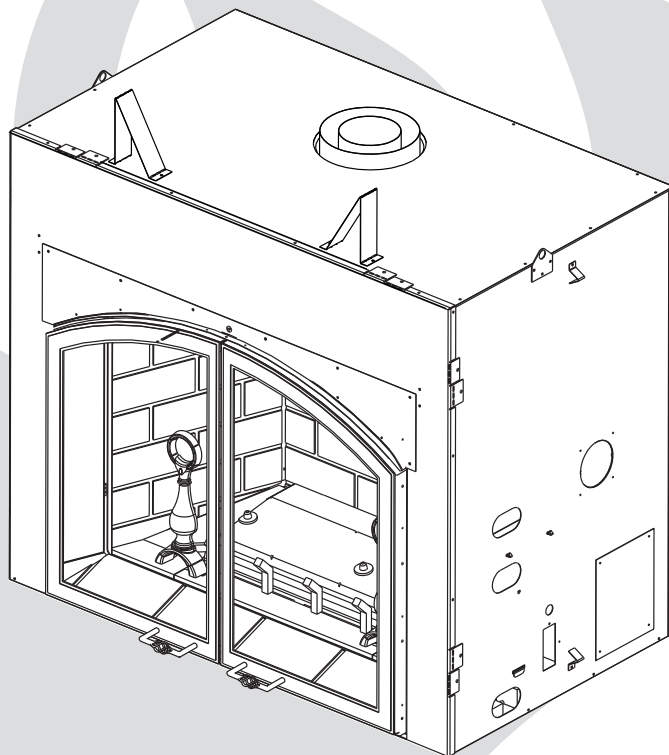

CERTIFIED FOR CANADA AND UNITED STATES USING ANSI/CSA METHODS.

SAFETY INFORMATION

! WARNING

If the information in these instructions are not followed exactly, a fire or explosion may result causing property damage, personal injury or loss of life.

- Do not store or use gasoline or other flammable vapors and liquids in the vicinity of this or any other appliance.
- WHAT TO DO IF YOU SMELL GAS:
 - Do not try to light any appliance.
 - Do not touch any electrical switch; do not use any phone in your building.
 - Immediately call your gas supplier from a neighbour's phone. Follow the gas supplier's instructions.
 - If you cannot reach your gas supplier, call the fire department.
- Installation and service must be performed by a qualified installer, service agency or the supplier.



APPLY SERIAL NUMBER LABEL FROM CARTON



Serial No. XXXXX00000
MODEL NO.

Wolf Steel Ltd., 24 Napoleon Rd., Barrie, ON, L4M 4Y8 Canada /
103 Miller Drive, Crittenden, Kentucky, USA, 41030

Phone (705)721-1212 • Fax (705)722-6031 • www.napoleonfireplaces.com • ask@napoleonproducts.com

TABLE OF CONTENTS

1.0	INSTALLATION OVERVIEW	3
2.0	INTRODUCTION	4
2.1	DIMENSIONS	5
2.2	GENERAL INSTRUCTIONS	5
2.3	GENERAL INFORMATION	6
2.4	RATING PLATE INFORMATION	7
3.0	VENTING	8
3.1	VENTING LENGTHS AND COMPONENTS	9
3.2	TYPICAL VENT INSTALLATION	10
3.3	SPECIAL VENT INSTALLATION	11
3.3.1	PERISCOPE TERMINATION	11
3.4	MINIMUM AIR TERMINAL LOCATION CLEARANCES	12
3.5	VENTING APPLICATION FLOW CHART	13
3.6	DEFINITIONS	13
3.7	ELBOW VENT LENGTH VALUES	13
3.8	TOP EXIT HORIZONTAL TERMINATION	14
3.9	VERTICAL TERMINATION	16
4.0	INSTALLATION	18
4.1	WALL AND CEILING PROTECTION	18
4.1.2	HORIZONTAL INSTALLATION	19
4.1.3	VERTICAL INSTALLATION	19
4.2	USING FLEXIBLE VENT COMPONENTS	20
4.2.1	HORIZONTAL AIR TERMINAL INSTALLATION	20
4.2.2	VERTICAL AIR TERMINAL INSTALLATION	21
4.2.3	APPLIANCE VENT CONNECTION	22
4.3	MOBILE HOME INSTALLATION	22
4.4	GAS INSTALLATION	23
5.0	FRAMING	24
5.1	MINIMUM CLEARANCE TO COMBUSTIBLES	26
5.2	MINIMUM CLEARANCE TO COMBUSTIBLE ENCLOSURES	27
5.3	MINIMUM MANTEL CLEARANCES	29
6.0	FINISHING	30
6.1	DOOR REMOVAL / INSTALLATION	30
6.2	LOG SHIPPING BRACKET	31
6.3	DECORATIVE BRICK PANEL INSTALLATION	32
6.4	LOG PLACEMENT	33
6.5	GLOWING EMBERS	34
6.6	CHARCOAL EMBERS	34
7.0	OPERATION	35
7.1	GENERAL TRANSMITTER LAYOUT	35
7.2	APPLIANCE OPERATION	35
7.3	HAND HELD REMOTE OPERATIONS	35
7.4	TEMPERATURE DISPLAY	36
7.5	ROOM THERMOSTAT	36
7.6	SMART THERMOSTAT	36
7.7	FLAME HEIGHT	37
7.8	FAN SPEED	37
7.9	CHILD PROOF FUNCTION	37
7.10	NIGHT LIGHTS™	38
7.11	LOW BATTERY / MANUAL BYPASS	38
7.12	IN THE EVENT OF A POWER FAILURE	38
7.13	CONTROL MODULE	38
8.0	ELECTRICAL INFORMATION	39
8.1	HARD WIRING CONNECTION	39
9.0	OPERATING INSTRUCTIONS	40
10.0	ADJUSTMENT	41
10.1	PILOT BURNER ADJUSTMENT	41
10.2	VENTURI ADJUSTMENT	41
10.3	FLAME CHARACTERISTICS	42
10.4	AIR CONTROL ROD ACCESS	42
11.0	MAINTENANCE	43
11.1	INNER ACCESS PANEL	43
11.2	NIGHT LIGHT™ REPLACEMENT	44
11.3	BLOWER REPLACEMENT	44
11.4	REMOTE RECEIVER REMOVAL	45
11.5	VALVE REMOVAL	45
11.6	"AUTO SPARK" BATTERY REMOVAL	46
11.7	CARE OF GLASS	46
11.8	RESTRICTING VERTICAL VENTS	46
12.0	REPLACEMENTS	47
13.0	TROUBLE SHOOTING	50
14.0	WARRANTY	53
15.0	SERVICE HISTORY	54

1.0 INSTALLATION OVERVIEW

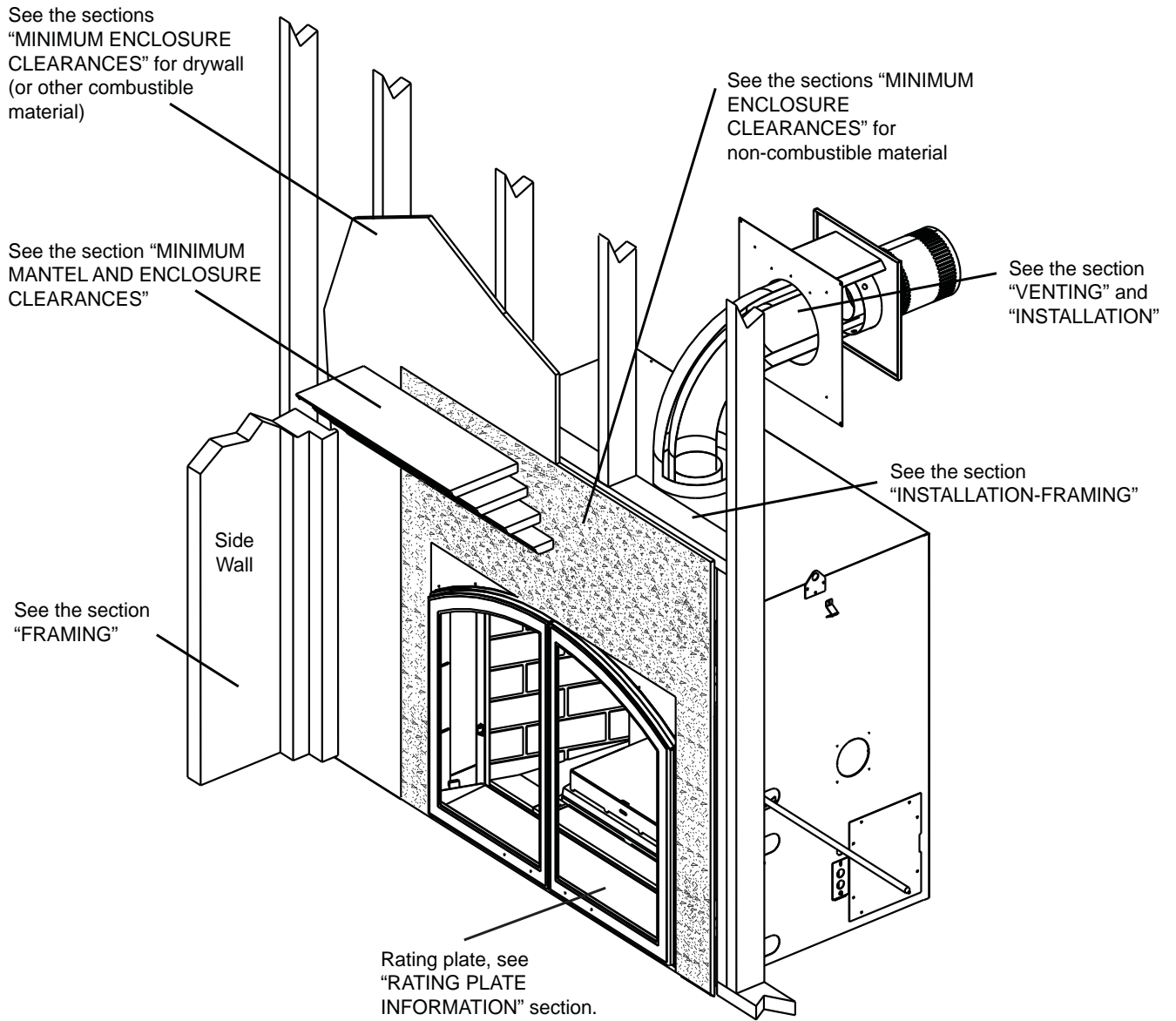

2.0 INTRODUCTION

WARNING

- **THIS APPLIANCE IS HOT WHEN OPERATED AND CAN CAUSE SEVERE BURNS IF CONTACTED.**
- Do not operate appliance before reading and understanding operating instructions. Failure to operate appliance according to operating instructions could cause fire or injury.
- Risk of fire or asphyxiation do not operate appliance with fixed glass removed.
- Do not connect 110 volts to the control valve.
- Risk of burns. The appliance should be turned off and cooled before servicing.
- Do not install damaged, incomplete or substitute components.
- Risk of cuts and abrasions. Wear protective gloves and safety glasses during installation. Sheet metal edges may be sharp.
- Do not burn wood or other materials in this appliance.
- Young children should be carefully supervised when they are in the same room as the appliance. Toddlers, young children and others may be susceptible to accidental contact burns. A physical barrier is recommended if there are at risk individuals in the house. To restrict access to an appliance or stove, install an adjustable safety gate to keep toddlers, young children and other at risk individuals out of the room and away from hot surfaces.
- Clothing or other flammable material should not be placed on or near the appliance.
- Due to high temperatures, the appliance should be located out of traffic and away from furniture and draperies.
- Ensure you have incorporated adequate safety measure to protect infants/toddlers from touching hot surfaces.
- Even after the appliance is out, the glass and/or screen will remain hot for an extended period of time.
- Check with your local hearth specialty dealer for safety screens and hearth guards to protect children from hot surfaces. These screens and guards must be fastened to the floor.
- Any safety screen or guard removed for servicing must be replaced prior to operating the appliance.
- It is imperative that the control compartments, burners and circulating blower and its passageway in the appliance and venting system are kept clean. The appliance and its venting system should be inspected before use and at least annually by a qualified service person. More frequent cleaning may be required due to excessive lint from carpeting, bedding material, etc. The appliance area must be kept clear and free from combustible materials, gasoline and other flammable vapors and liquids.
- Under no circumstances should this appliance be modified.
- This appliance must not be connected to a chimney flue pipe serving a separate solid fuel burning appliance.
- Do not use this appliance if any part has been under water. Immediately call a qualified service technician to inspect the appliance and to replace any part of the control system and any gas control which has been under water.
- Do not operate the appliance with the glass door removed, cracked or broken. Replacement of the glass should be done by a licensed or qualified service person.
- Do not strike or slam shut the appliance glass door.
- This appliance uses and requires a fast acting thermocouple. Replace only with a fast acting thermocouple supplied by Wolf Steel Ltd.
- Pressure relief doors must be kept closed while the appliance is operating to prevent exhaust fumes containing carbon monoxide, from entering into the home. Temperatures of the exhaust escaping through these openings can also cause the surrounding combustible materials to overheat and catch fire.
- Only doors / optional fronts certified with the unit are to be installed on the appliance.
- Keep the packaging material out of reach of children and dispose of the material in a safe manner. As with all plastic bags, these are not toys and should be kept away from children and infants.
- As with any combustion appliance, we recommend having your appliance regularly inspected and serviced as well as having a Carbon Monoxide Detector installed in the same area to defend you and your family against Carbon Monoxide.
- Ensure clearances to combustibles are maintained when building a mantel or shelves above the appliance. Elevated temperatures can cause melting, deformation, discolouration or premature failure of T.V. or other electronic components.

3.1A

2.1 DIMENSIONS

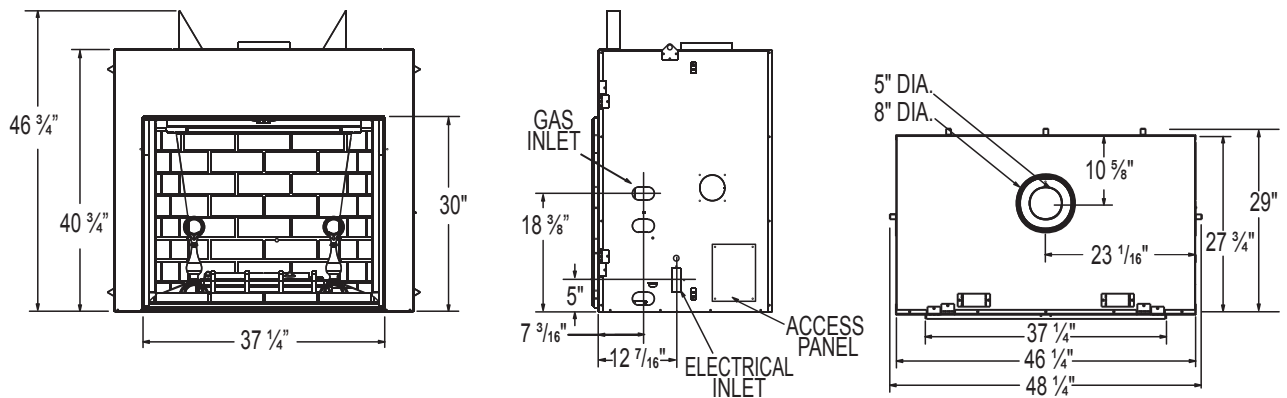

2.2 GENERAL INSTRUCTIONS

! WARNING
ALWAYS LIGHT THE PILOT WHETHER FOR THE FIRST TIME OR IF THE GAS SUPPLY HAS RAN OUT, WITH THE GLASS DOOR OPENED OR REMOVED.
PROVIDE ADEQUATE CLEARANCE FOR SERVICING AND OPERATING THE APPLIANCE.
PROVIDE ADEQUATE VENTILATION.
NEVER OBSTRUCT THE FRONT OPENING OF THE APPLIANCE.
OBJECTS PLACED IN FRONT OF THE APPLIANCE MUST BE KEPT A MINIMUM OF 48" FROM THE FRONT FACE OF THE UNIT.
SURFACES AROUND AND ESPECIALLY ABOVE THE APPLIANCE CAN BECOME HOT. AVOID CONTACT WHEN THE APPLIANCE IS OPERATING.
FIRE RISK. EXPLOSION HAZARD.
HIGH PRESSURE WILL DAMAGE VALVE. DISCONNECT GAS SUPPLY PIPING BEFORE PRESSURE TESTING GAS LINE AT TEST PRESSURES ABOVE 1/2 PSIG. CLOSE THE MANUAL SHUT-OFF VALVE BEFORE PRESSURE TESTING GAS LINE AT TEST PRESSURES EQUAL TO OR LESS THAN 1/2 PSIG.
USE ONLY WOLF STEEL APPROVED OPTIONAL ACCESSORIES AND REPLACEMENT PARTS WITH THIS APPLIANCE. USING NON-LISTED ACCESSORIES (BLOWERS, DOORS, LOUVRES, TRIMS, GAS COMPONENTS, VENTING COMPONENTS, ETC.) COULD RESULT IN A SAFETY HAZARD AND WILL VOID THE WARRANTY AND CERTIFICATION.

THIS GAS APPLIANCE SHOULD BE INSTALLED AND SERVICED BY A QUALIFIED INSTALLER to conform with local codes. Installation practices vary from region to region and it is important to know the specifics that apply to your area, for example in Massachusetts State:

- This product must be installed by a licensed plumber or gas fitter when installed within the commonwealth of Massachusetts.
- The appliance damper must be removed or welded in the open position prior to installation of a appliance insert or gas log.
- The appliance off valve must be a "T" handle gas cock.
- The flexible connector must not be longer than 36 inches.
- A Carbon Monoxide detector is required in all rooms containing gas fired appliances.
- The appliance is not approved for installation in a bedroom or bathroom unless the unit is a direct vent sealed combustion product.

The installation must conform with local codes or, in absence of local codes, the National Gas and Propane Installation Code CSA B149.1 in Canada, or the National Fuel Gas Code, ANSI Z223.1 / NFPA 54 in the United States. Suitable for mobile home installation if installed in accordance with the current standard CAN/CSA Z240MH Series, for gas equipped mobile homes, in Canada or ANSI Z223.1 and NFPA 54 in the United States.



We suggest that our gas hearth products be installed and serviced by professionals who are certified in the U.S. by the National Fireplace Institute® (NFI) as NFI Gas Specialists

As long as the required clearance to combustibles is maintained, the most desirable and beneficial location for an appliance is in the center of a building, thereby allowing the most efficient use of the heat created. The location of windows, doors and the traffic flow in the room where the appliance is to be located should be considered. If possible, you should choose a location where the vent will pass through the house without cutting a floor or roof joist.

If the appliance is installed directly on carpeting, vinyl tile or other combustible material other than wood flooring, the appliance shall be installed on a metal or wood panel extending the full width and depth.

If the optional fan or blower is installed, the junction box must be electrically connected and grounded in accordance with local codes, use the current CSA C22.1 Canadian Electrical Code in Canada or the ANSI/NFPA 70 National Electrical code in the United States.

4.1

2.3 GENERAL INFORMATION

FOR YOUR SATISFACTION, THIS APPLIANCE HAS BEEN TEST-FIRED TO ASSURE ITS OPERATION AND QUALITY!

APPLIANCE		
	NG	LP
Altitude (FT)	0-4,500	0-4500
Max. Input (BTU/HR)	43,000	43,000
Max. Output Steady State (BTU/HR)	33,540	34,000
Efficiency (w/the fan on)	78%	79%
Min. Inlet Gas Supply Pressure	4.5" Water Column	11" Water Column
Max. Inlet Gas Supply Pressure	7" Water Column	13" Water Column
Manifold Pressure (Under Flow Conditions)	3.5" Water Column	10" Water Column

This appliance is approved for bathroom, bedroom and bed-sitting room installations and is certified for mobile home installation.

This appliance is certified to be installed in an aftermarket permanently located, manufactured (mobile) home, where not prohibited by local codes.

This appliance is only for use with the type of gas indicated on the rating plate. This appliance is not convertible for use with other gases, unless kit is used. Not external electricity (110 volts or 24 volts) is required for the gas system operation.

Expansion / contraction noised during heating up and cooling down cycles are normal and are to be expected. Change in flame appearance from "HI" to "LO" is more evident in natural gas than in propane.



We suggest that our gas hearth products be installed and serviced by professionals who are certified in the U.S. by the National Fireplace Institute® (NFI) as NFI Gas Specialists.

2.4 RATING PLATE INFORMATION

INSTALLER: It is your responsibility to check off the appropriate box on the rating plate according to the model, venting and gas type of the appliance.

For rating plate location, see "INSTALLATION OVERVIEW" section.

The illustration is for reference only. Refer to the rating plate on the appliance for accurate information.

		<p>CERTIFIED UNDER / HOMOLOGUE SELON LES NORMES: CSA 2.33-2009, ANSI Z21.88-2009 VENTED GAS FIREPLACE HEATER / APPAREIL DE CHAUFFAGE ALIMENTÉ AU GAZ ET VENTILÉ</p> <p>VENTED GAS FIREPLACE HEATER, APPROVED FOR BEDROOM, BATHROOM AND BED-SITTING ROOM INSTALLATION. SUITABLE FOR MOBILE HOME INSTALLATION IF INSTALLED IN ACCORDANCE WITH THE CURRENT STANDARD CAN/CSA Z240MH SERIES GAS EQUIPPED MOBILE HOMES, IN CANADA OR IN THE UNITED STATES THE MANUFACTURED HOME CONSTRUCTION AND SAFETY STANDARD, TITLE 24 CFR, PART 3280. WHEN THIS US STANDARD IS NOT APPLICABLE USE THE STANDARD FOR FIRE SAFETY CRITERIA FOR MANUFACTURED HOME INSTALLATIONS, SITES AND COMMUNITIES, ANSI/MFPA 501A.</p> <p>FOYER DE CHAUFFAGE AU GAZ AVEC ÉVACUATION. HOMOLOGUE POUR INSTALLATION DANS UNE CHAMBRE À COUCHER, UNE SALLE DE BAIN ET UN STUDIO. APPROPRIÉ POUR INSTALLATION DANS UNE MAISON MOBILE SI SON INSTALLATION CONFORME AUX EXIGENCES DE LA NORME CAN/CSA Z240MH SÉRIE DE MAISONS MOBILES ÉQUIPÉES AU GAZ. VALABLE POUR LA CANADA OU AUX ÉTATS-UNIS DE LA NORME DE SÉCURITÉ ET DE CONSTRUCTION DE MAISONS MANUFACTURÉES, TITRE 24 CFR, SECTION 3280. DANS LE CAS OU CETTE NORME D'ÉTATS-UNIS NE PEUT ÊTRE APPLIQUÉE, SE RÉFÉRER À LA NORME RELATIVE AU CRITÈRE DE MESURES DE SÉCURITÉ CONTRE L'INCENDIE POUR LES INSTALLATIONS DANS LES MAISONS MANUFACTURÉES, LES SITES ET LES COMMUNAUTÉS, ANS/MFPA 501A.</p>																	
<p>REFERENCE # 15529</p>		<p>UN COMBUSTIBLE SOLIDE NE DOIT PAS ÊTRE UTILISÉ AVEC CET APPAREIL. UTILISER AVEC LES PORTES VITRÉES HOMOLOGUÉES SEULEMENT AVEC CETTE UNITÉ.</p>																	
<p>NOT FOR USE WITH SOLID FUEL. FOR USE WITH GLASS DOORS CERTIFIED WITH THIS UNIT ONLY.</p>		<p>MODEL <input type="checkbox"/> GD80NT</p>	<p>MODEL <input type="checkbox"/> GD80PT</p>																
<p>WARNING: DO NOT ADD ANY MATERIAL TO THE APPLIANCE, WHICH WILL COME IN CONTACT WITH THE FLAMES, OTHER THAN THAT SUPPLIED BY THE MANUFACTURER WITH THE APPLIANCE.</p>		<p>0-4500FT (0-1370M) 43,000 BTU/H 29,000 BTU/H #30 MINIMUM SUPPLY PRESSURE / PRESSION D'ALIMENTATION MINIMALE</p>	<p>0-4500FT (0-1370M) 43,000 BTU/H 26,000BTU/H #49 10" WATER COLUMN/D'UNE COLONNE D'EAU 11" WATER COLUMN/D'UNE COLONNE D'EAU 13" WATER COLUMN/D'UNE COLONNE D'EAU</p>																
<p>MINIMUM CLEARANCE TO COMBUSTIBLE MATERIALS:</p> <table border="0"> <tr> <td>TOP</td> <td>0</td> <td>RECESSED DEPTH</td> <td>29"</td> </tr> <tr> <td>FLOOR</td> <td>0</td> <td>VENT</td> <td>2"</td> </tr> <tr> <td>SIDES</td> <td>0</td> <td>MANTLE</td> <td>8"</td> </tr> <tr> <td>BACK</td> <td>0</td> <td></td> <td></td> </tr> </table>		TOP	0	RECESSED DEPTH	29"	FLOOR	0	VENT	2"	SIDES	0	MANTLE	8"	BACK	0			<p>3.5" WATER COLUMN/D'UNE COLONNE D'EAU 4.5" WATER COLUMN/D'UNE COLONNE D'EAU 7.0" WATER COLUMN/D'UNE COLONNE D'EAU</p>	<p>ALTIITUDE / ÉLEVATION INPUT / ALIMENTATION REDUCED INPUT / ALIMENTATION RÉDUITE ORIFICE / INJECTEUR MINIMUM SUPPLY PRESSURE / PRESSION D'ALIMENTATION MINIMALE MINIMUM SUPPLY PRESSURE / PRESSION D'ALIMENTATION MAXIMALE</p>
TOP	0	RECESSED DEPTH	29"																
FLOOR	0	VENT	2"																
SIDES	0	MANTLE	8"																
BACK	0																		
<p>TOP SIDES & BACK: PER STAND OFF SPACERS FOR FRAMING MATERIALS. FOR FINISHING MATERIALS SEE OWNERS MANUAL * MAXIMUM HORIZONTAL EXTENSION / L'EXTENSION HORIZONTALE MAXIMALE: 2". SEE INSTRUCTION MANUAL FOR GREATER EXTENSIONS. SEE OWNER'S INSTRUCTION MANUAL FOR MINIMUM AND MAXIMUM VENT LENGTHS.</p>		<p>THE APPLIANCE MUST BE VENTED USING THE APPROPRIATE NAPOLEON VENT KITS. SEE OWNERS INSTALLATION MANUAL FOR VENTING SPECIFICS. PROPER REINSTALLATION AND RESEALING IS NECESSARY AFTER SERVING THE VENT-AIR INTAKE SYSTEM.</p>																	
<p>ELECTRICAL RATING: 115V 0.82AMP, 60HZ MADE IN CANADA / FABRIQUE AU CANADA WOLF STEEL LTD. BARRIE, ONTARIO, CANADA</p>		<p>L'APPAREIL DOIT ÉVACUER SES GAZ EN UTILISANT L'ENSEMBLE D'ÉVACUATION PROPRE À NAPOLEON. RÉFÉRER AU MANUEL D'INSTALLATION DE PROPRIÉTAIRE POUR L'ÉVACUATION PRÉCISE. IL EST IMPORTANT DE BIEN REINSTALLER ET RESCELLER L'ÉVENT APRES AVOIR ASSURÉ LE MAINTIEN DU SYSTÈME DE PRISE D'AIR.</p>																	
		<p>SERIAL NUMBER/NO. DE SÉRIE: GD80</p>																	
		<p>AVERTISSEMENT: N'AJOUTEZ PAS À CET APPAREIL AUCUN MATÉRIEL DEVANT ENTRER EN CONTACT AVEC LES FLAMMES AUTRE QUE CELUI QUI EST FOURNI AVEC CET APPAREIL PAR LE FABRICANT. DÉGAGEMENTS MINIMAUX DES MATÉRIEAUX COMBUSTIBLES: DESSUS 0 PROFONDEUR D'ENCASTRE 29" PLANCHER 0 ÉVENT 2" CÔTES 0 MANTEAU 8" ARRIÈRE 0 DESSUS, CÔTES & ARRIÈRE: SELON LES ESPACEURS DE DÉGAGEMENT POUR LES MATÉRIEAUX D'OSSATURE SELON LE MANUEL DE PROPRIÉTAIRE POUR LES MATÉRIEAUX DE FINITION. * L'EXTENSION HORIZONTALE MAXIMALE: 2". RÉFÉRER AU MANUEL D'INSTRUCTION POUR DES EXTENSIONS PLUS GRANDES. RÉFÉRER AU MANUEL D'INSTALLATION DE PROPRIÉTAIRE.</p>																	
		<p>CLASSIFICATION: 115V 0.82AMP, 60HZ W385-0294</p>																	

3.0 VENTING

WARNING

RISK OF FIRE, MAINTAIN SPECIFIED AIR SPACE CLEARANCES TO VENT PIPE AND APPLIANCE.

IF VENTING IS INCLUDED WITH SPACERS THE VENT SYSTEM MUST BE SUPPORTED EVERY 3 FEET FOR BOTH VERTICAL AND HORIZONTAL RUNS. USE SUPPORTS OR EQUIVALENT NON-COMBUSTIBLE STRAPPING TO MAINTAIN THE REQUIRED CLEARANCE FROM COMBUSTIBLES. USE WOLF STEEL LTD. SUPPORT RING ASSEMBLY W010-0370 OR EQUIVALENT NON-COMBUSTIBLE STRAPPING TO MAINTAIN THE MINIMUM CLEARANCE TO COMBUSTIBLES FOR BOTH VERTICAL AND HORIZONTAL RUNS. SPACERS ARE ATTACHED TO THE INNER PIPE AT PREDETERMINED INTERVALS TO MAINTAIN AN EVEN AIR GAP TO THE OUTER PIPE. THIS GAP IS REQUIRED FOR SAFE OPERATION. A SPACER IS REQUIRED AT THE START, MIDDLE AND END OF EACH ELBOW TO ENSURE THIS GAP IS MAINTAINED. THESE SPACERS MUST NOT BE REMOVED.

THIS APPLIANCE USES A 5" EXHAUST / 8" AIR INTAKE VENT PIPE SYSTEM.

Refer to the section applicable to your installation.

For safe and proper operation of the appliance follow the venting instruction exactly. Deviation from the minimum vertical vent length can create difficulty in burner start-up and/or carboning. Under extreme vent configurations, allow several minutes (5-15) for the flame to stabilize after ignition. Vent lengths that pass through unheated spaces (attics, garages, crawl spaces) should be insulated with the insulation wrapped in a protective sleeve to minimize condensation. Provide a means for visually checking the vent connection to the appliance after the appliance is installed. Use a firestop, vent pipe shield or attic insulation shield when penetrating interior walls, floor or ceiling.

NOTE: If for any reason the vent air intake system is disassembled; reinstall per the instructions provided for the initial installation.

7.2

3.1 VENTING LENGTHS AND COMPONENTS

Use only Wolf Steel, Simpson Dura-Vent, Selkirk Direct Temp, American Metal Amerivent or Metal-Fab venting components. Minimum and maximum vent lengths, for both horizontal and vertical installations, and air terminal locations for either system are set out in this manual and must be adhered to. For Simpson Dura-Vent, Selkirk Direct Temp, American Metal Amerivent and Metal-Fab follow the installation procedure provided with the venting components.

A starter adaptor must be used with the following vent systems and may be purchased from the corresponding supplier:

PART	5"/8"	SUPPLIER	WEBSITE
Duravent	W175-0170	Wolf Steel	www.duravent.com
Amerivent	5DSC-N2	American Metal	www.americanmetalproducts.com
Direct Temp	5DT-AA	Selkirk	www.selkirkcorp.com
SuperSeal	5DDA	Metal-Fab	www.mtlfab.com

For Simpson Dura-Vent, Selkirk Direct Temp, American Metal Amerivent and Metal-Fab follow the installation procedure found on the website for your venting supplier.

For vent systems that provide seals on the inner exhaust flue, only the outer air intake joints must be sealed using a red high temperature silicone (RTV). This same sealant may be used on both the inner exhaust and outer intake vent pipe joints of all other approved vent systems except for the exhaust vent pipe connection to the appliance flue collar which must be sealed using the black high temperature sealant Mill Pac.

When using Wolf Steel venting components, use only approved Wolf Steel rigid / flexible components with the following termination kits: wall terminal kit **GD422-1**, **GD422R-1**, or 1/12 to 7/12 pitch roof terminal kit **GD410**, 8/12 to 12/12 roof terminal kit **GD411**, flat roof terminal kit **GD412** or periscope kit **GD401** (for wall penetration below grade). With flexible venting, in conjunction with the various terminations, use either the 5 foot vent kit **GD420** or the 10 foot vent kit **GD430**.

For optimum flame appearance and appliance performance, keep the vent length and number of elbows to a minimum.

The air terminal must remain unobstructed at all times. Examine the air terminal at least once a year to verify that it is unobstructed and undamaged.

Rigid and flexible venting systems must not be combined. Different venting manufacturer components must not be combined.

These vent kits allow for either horizontal or vertical venting of the appliance. The maximum allowable horizontal run is 20 feet. The maximum allowable vertical vent length is 40 feet. The maximum number of vent connections is two horizontally or three vertically (excluding the appliance and the air terminal connections) when using flexible venting.

Horizontal runs may have a 0" rise per foot however for optimum performance it is recommended that all horizontal runs have a minimum 1/4" rise per foot using flexible venting. For safe and proper operation of the appliance, follow the venting instructions exactly.

A terminal shall not terminate directly above a sidewalk or paved driveway which is located between two single family dwellings and serves both dwellings. Local codes or regulations may require different clearances. Do not allow the inside liner to bunch up on horizontal or vertical runs and elbows. Keep it pulled tight. A 1 1/4" air gap all around between the inner liner and outer liner is required for safe operation.

3.2 TYPICAL VENT INSTALLATION

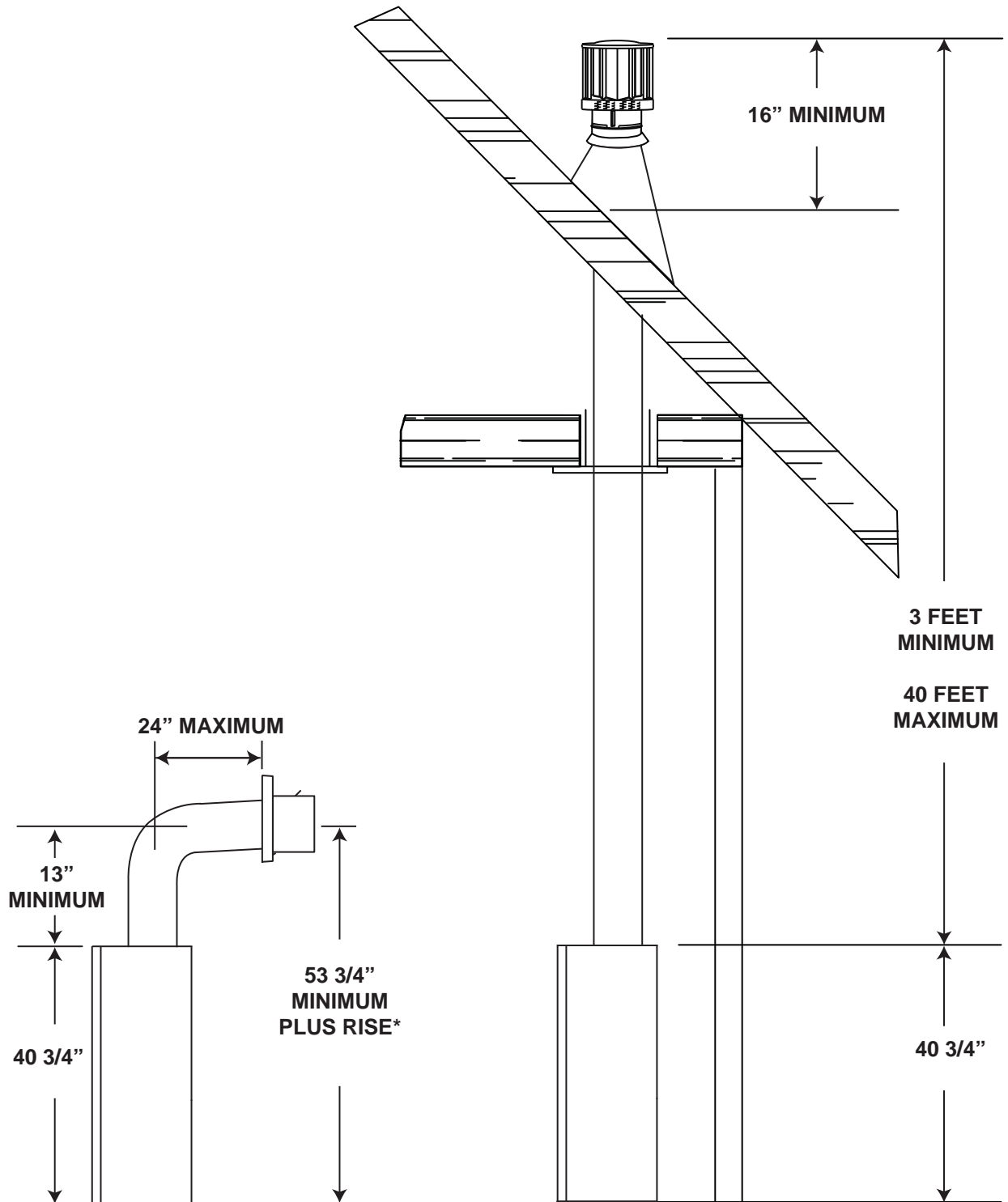

* See "VENTING" section

Horizontal runs may have a 0" rise per foot in all cases using Simpson Dura-Vent, Selkirk Direct Temp, American Metal Amerivent or Wolf Steel Ltd. rigid or flexible venting components when venting as illustrated.

If vertical rises greater than 57" are necessary, the increased rise must be deducted from the horizontal run.

3.3 SPECIAL VENT INSTALLATION

3.3.1 PERISCOPE TERMINATION

Use the periscope kit to locate the air termination above grade. The periscope must be installed so that when final grading is completed, the bottom air slot is located a minimum 12" above grade. The maximum allowable vent length is 10'.

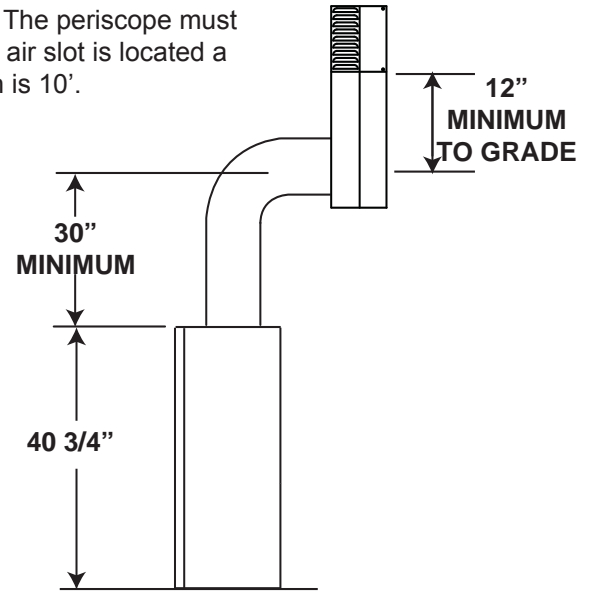

9.1

3.4 MINIMUM AIR TERMINAL LOCATION CLEARANCES

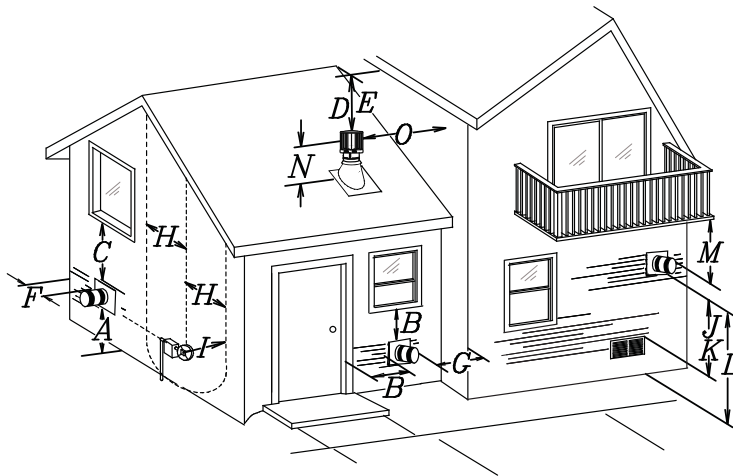

COVERED BALCONY APPLICATIONS

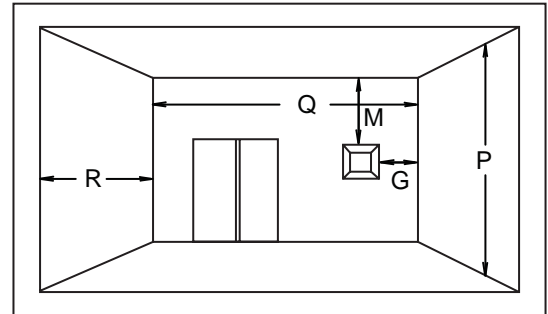

Q_{MIN}	= 3 feet
R_{MAX}	= 2 x Q_{ACTUAL}
R_{MAX}	≤ 15 feet

INSTALLATIONS			
CANADA	U.S.A.		
A	12"	12"	Clearance above grade, veranda porch, deck or balcony.
B	12" ^Δ	9" ^Δ	Clearance to windows or doors that open.
C	12" *	12" *	Clearance to permanently closed windows.
D	18" **	18" **	Vertical clearance to ventilated soffits located above the terminal within a horizontal distance of 2' from the centerline of the terminal.
E	12" **	12" **	Clearance to unventilated soffit.
F	0"	0"	Clearance to an outside corner wall.
G	0" ***	0" ***	Clearance to an inside non-combustible corner wall or protruding non-combustible obstructions (chimney, etc.).
	2" ***	2" ***	Clearance to an inside combustible corner wall or protruding combustible obstructions (vent chase, etc.).
H	3'	3' ****	Clearance to each side of the centerline extended above the meter / regulator assembly to a maximum vertical distance of 15'.
I	3'	3' ****	Clearance to a service regulator vent outlet.
J	12"	9"	Clearance to a non-mechanical air supply inlet to the building or a combustion air inlet to any other appliance.
K	6'	3'	Clearance to a mechanical air supply inlet.
L	7' ‡	7' ****	Clearance above a paved sidewalk or paved driveway located on public property.
M	12" ††	12" ****	Clearance under a veranda, porch, deck or balcony.
N	16"	16"	Clearance above the roof.
O	2' †*	2' †*	Clearance from an adjacent wall including neighbouring buildings.
P	8'	8'	Roof must be non-combustible without openings.
Q	3'	3'	See chart for wider wall dimensions.
R	6'	6'	See chart for deeper wall dimensions. The terminal shall not be installed on any wall that has an opening between the terminal and the open side of the structure.

Δ The terminal shall not be located less than 6 feet under a window that opens on a horizontal plane in a structure with three walls and a roof.

* Recommended to prevent condensation on windows and thermal breakage

** It is recommended to maximize the distance to vinyl clad soffits.

*** The periscope requires a minimum 18" clearance from an inside corner.

**** This is a recommended distance. For additional requirements check local codes.

† 3 feet above if within 10 feet horizontally.

‡ A vent shall not terminate directly above a sidewalk or paved driveway that is located between two single family dwellings and serves both dwellings.

†† Permitted only if the veranda, porch, or deck is fully open on a minimum of two sides beneath the floor.

†* Recommended to prevent recirculation of exhaust products. For additional requirements check local codes.

3.5 VENTING APPLICATION FLOW CHART

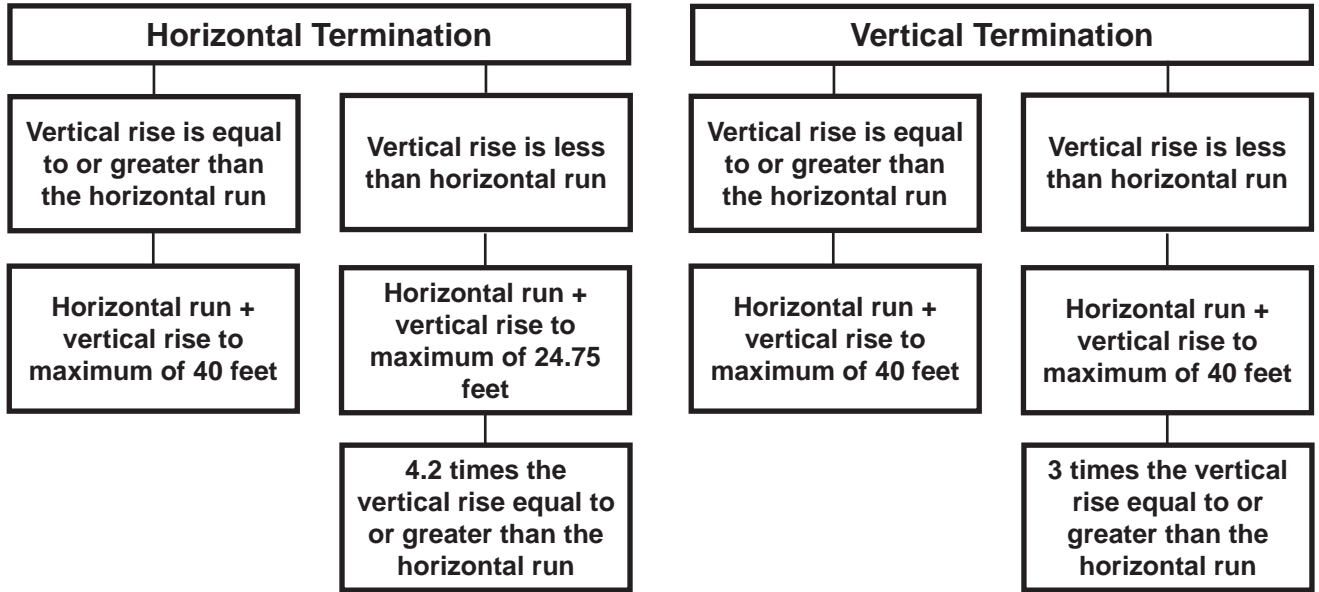

13.1

3.6 DEFINITIONS

For the following symbols used in the venting calculations and examples are:

> - greater than

≥ - equal to or greater than

< - less than

≤ - equal to or less than

H_T - total of both horizontal vent lengths (H_r) and offsets (H_o) in feet

H_R - combined horizontal vent lengths in feet

H_o - offset factor: .03 (total degrees of offset - 90°*) in feet

V_T - combined vertical vent lengths in feet

14.1

3.7 ELBOW VENT LENGTH VALUES

	<u>FEET</u>	<u>INCHES</u>
1°	0.03	0.5
15°	0.45	6.0
30°	0.9	11.0
45°	1.35	16.0
90°*	2.7	32.0

* The first 90° offset has a zero value and is shown in the formula as - 90°

15.1

3.8 TOP EXIT HORIZONTAL TERMINATION

$(H_T) \leq (V_T)$

Simple venting configuration (only one 90° elbow)

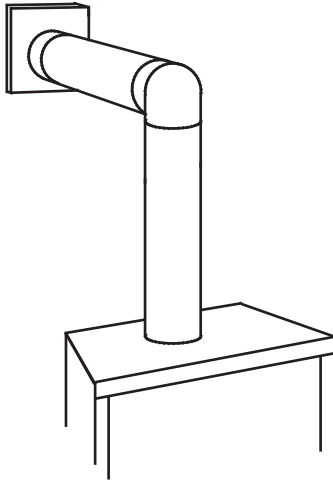

See graph to determine the required vertical rise V_T for the required horizontal run H_T

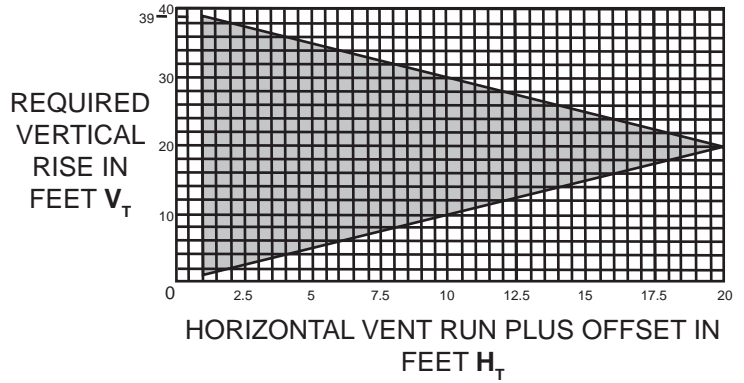

The shaded area within the lines represents acceptable values for H_T and V_T

For vent configurations requiring more than one 90° elbow, the following formulas apply:

Formula 1: $H_T \leq V_T$

Formula 2: $H_T + V_T \leq 40$ feet

Example 1:

$V_1 = 3$ FT

$V_2 = 8$ FT

$V_T = V_1 + V_2 = 3$ FT + 8 FT = 11 FT

$H_1 = 2.5$ FT

$H_2 = 2$ FT

$H_R = H_1 + H_2 = 2.5 + 2 = 4.5$ FT

$H_O = .03$ (three 90° elbows - 90°) = .03 (270° - 90°) = 5.4 FT

$H_T = H_R + H_O = 4.5 + 5.4 = 9.9$ FT

$H_T + V_T = 9.9 + 11 = 20.9$ FT

Formula 1: $H_T \leq V_T$
 $9.9 \leq 11$

Formula 2: $H_T + V_T \leq 40$ FT
 $20.9 \leq 40$

Since both formulas are met, this vent configuration is acceptable.

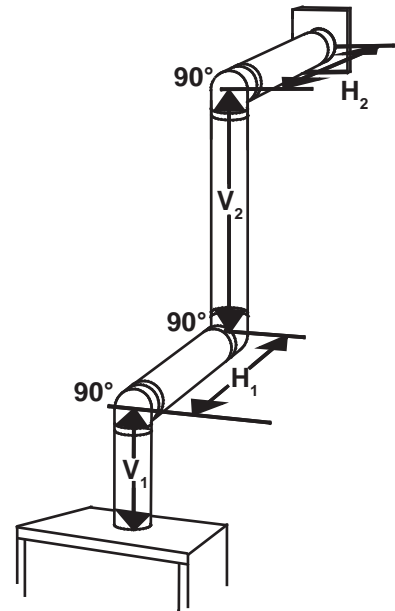

16.1A

$$(H_T) > (V_T)$$

Simple venting configuration (only one 90° elbow)

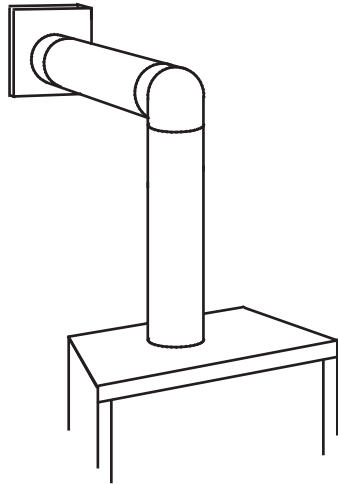

See graph to determine the required vertical rise V_T for the required horizontal run H_T .

REQUIRED VERTICAL RISE IN INCHES V_T

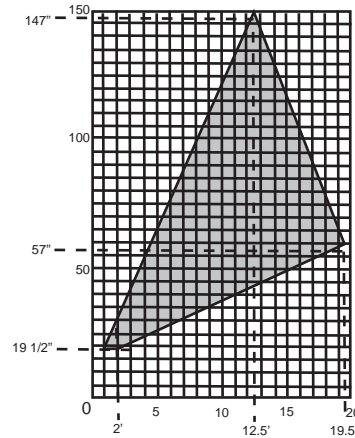

HORIZONTAL VENT RUN PLUS OFFSET IN FEET H_T
The shaded area within the lines represents acceptable values for H_T and V_T

For vent configurations requiring more than one 90° elbow, the following formulas apply:

Formula 1: $H_T \leq 4.2 V_T$

Formula 2: $H_T + V_T \leq 24.75$ feet

Example 2:

$$V_1 = V_T = 6 \text{ FT}$$

$$H_1 = 3 \text{ FT}$$

$$H_2 = 5 \text{ FT}$$

$$H_R = H_1 + H_2 = 3 + 5 = 8 \text{ FT}$$

$$H_O = .03 (\text{two } 90^\circ \text{ elbows} - 90^\circ) = .03 (180^\circ - 90^\circ) = 2.7 \text{ FT}$$

$$H_T = H_R + H_O = 8 + 2.7 = 10.7 \text{ FT}$$

$$H_T + V_T = 10.7 + 6 = 16.7 \text{ FT}$$

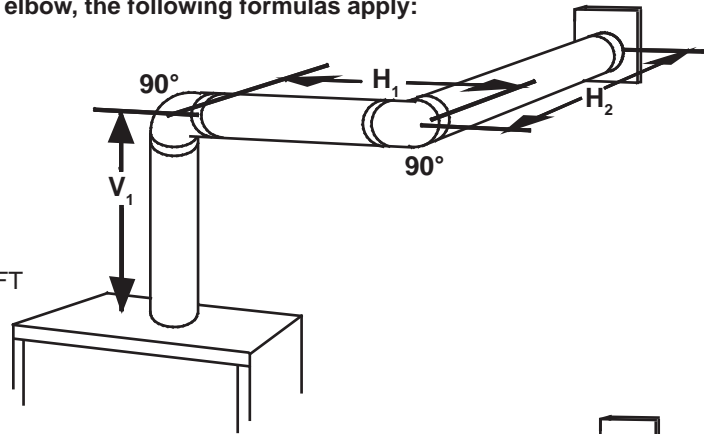

Formula 1:

$$H_T \leq 4.2 V_T$$

$$4.2 V_T = 4.2 \times 6 = 25.2 \text{ FT}$$

$$10.7 \leq 25.2$$

Formula 2:

$$H_T + V_T \leq 24.75 \text{ FT}$$

$$16.7 \leq 24.75$$

Since both formulas are met, this vent configuration is acceptable.

Example 3:

$$V_1 = 4 \text{ FT}$$

$$V_2 = 1.5 \text{ FT}$$

$$V_T = V_1 + V_2 = 4 + 1.5 = 5.5 \text{ FT}$$

$$H_1 = 2 \text{ FT}$$

$$H_2 = 1 \text{ FT}$$

$$H_3 = 1 \text{ FT}$$

$$H_4 = 1.5 \text{ FT}$$

$$H_R = H_1 + H_2 + H_3 + H_4 = 2 + 1 + 1 + 1.5 = 5.5 \text{ FT}$$

$$H_O = .03 (\text{four } 90^\circ \text{ elbows} - 90^\circ) = .03 (360^\circ - 90^\circ) = 8.1 \text{ FT}$$

$$H_T = H_R + H_O = 5.5 + 8.1 = 13.6 \text{ FT}$$

$$H_T + V_T = 13.6 + 5.5 = 19.1 \text{ FT}$$

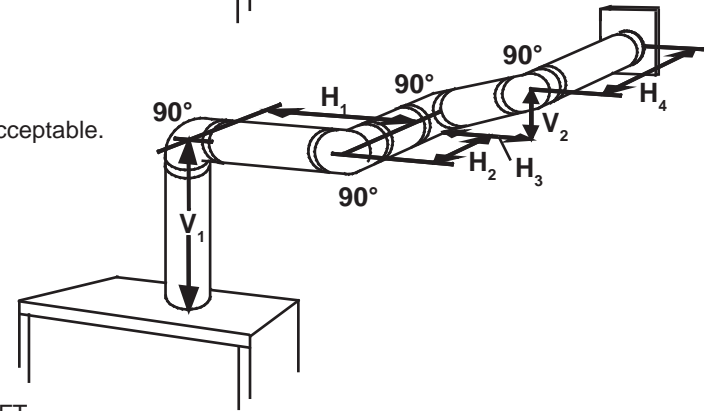

Formula 1:

$$H_T \leq 4.2 V_T$$

$$4.2 V_T = 4.2 \times 5.5 = 23.1 \text{ FT}$$

$$13.6 \leq 23.1$$

Formula 2:

$$H_T + V_T \leq 24.75 \text{ FT}$$

$$19.1 \leq 24.75$$

Since both formulas are met, this vent configuration is acceptable.

3.9 VERTICAL TERMINATION

$$(H_T) \leq (V_T)$$

Simple venting configurations.

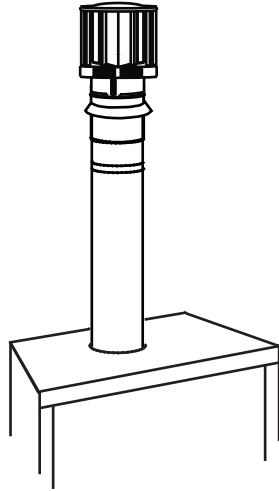

See graph to determine the required vertical rise V_T for the required horizontal run H_T .

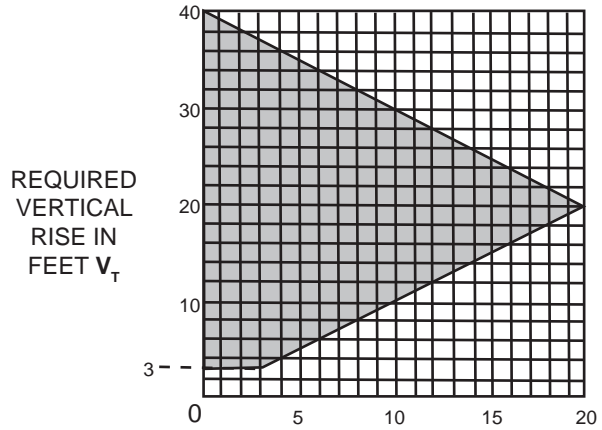

HORIZONTAL VENT RUN PLUS OFFSET IN FEET H_T
The shaded area within the lines represents acceptable values for H_T and V_T

For vent configurations requiring one or more 90° elbows the following formulas apply:

Formula 1: $H_T \leq V_T$

Formula 2: $H_T + V_T \leq 40$ feet

Example 6:

$V_1 = 5$ FT

$V_2 = 6$ FT

$V_3 = 10$ FT

$V_T = V_1 + V_2 + V_3 = 5 + 6 + 10 = 21$ FT

$H_1 = 8$ FT

$H_2 = 2.5$ FT

$H_R = H_1 + H_2 = 8 + 2.5 = 10.5$ FT

$H_O = .03$ (four 90° elbows - 90°)

$= .03 (360^\circ - 90^\circ) = 8.1$ FT

$H_T = H_R + H_O = 10.5 + 8.1 = 18.6$ FT

$H_T + V_T = 18.6 + 21 = 39.6$ FT

Formula 1: $H_T \leq V_T$
 $18.6 \leq 21$

Formula 2: $H_T + V_T \leq 40$ FT
 $39.6 \leq 40$

Since both formulas are met, this vent configuration is acceptable.

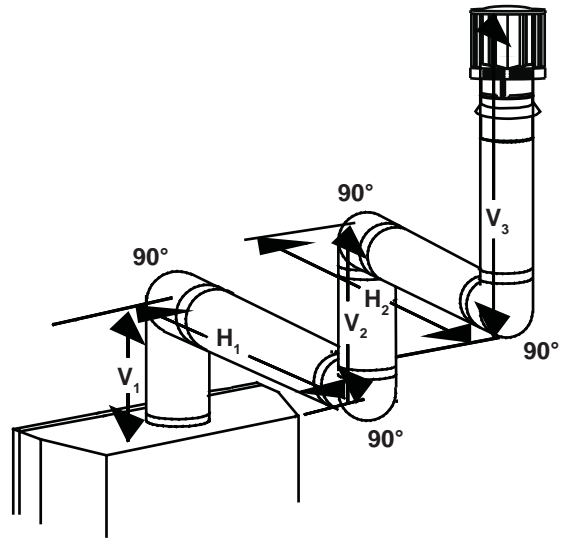

$(H_T) > (V_T)$

Simple venting configurations.

See graph to determine the required vertical rise V_T for the required horizontal run H_T .

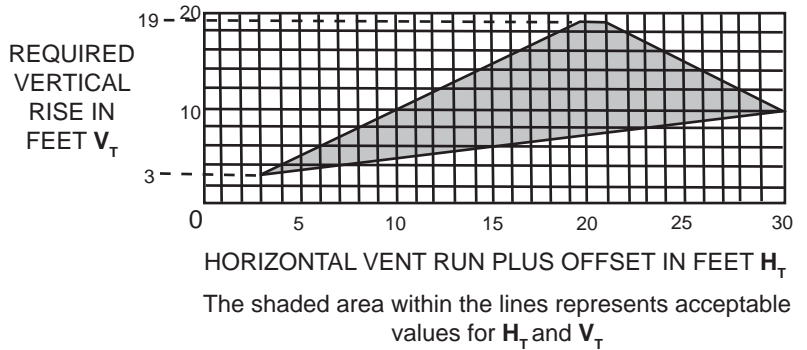
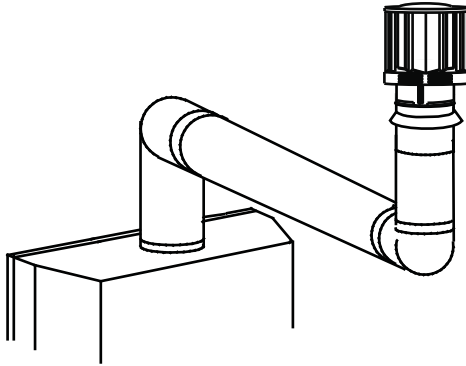

For vent configurations requiring more than two 90° elbows the following formulas apply:

Formula 1: $H_T \leq 3V_T$

Formula 2: $H_T + V_T \leq 40$ feet

Example 2:

- $V_1 = 2$ FT
- $V_2 = 1$ FT
- $V_3 = 1.5$ FT
- $V_T = V_1 + V_2 + V_3 = 2 + 1 + 1.5 = 4.5$ FT
- $H_1 = 6$ FT
- $H_2 = 2$ FT
- $H_R = H_1 + H_2 = 6 + 2 = 8$ FT
- $H_O = .03$ (four 90° elbows - 90°)
- $= .03$ (360° - 90°) = 8.1 FT
- $H_T = H_R + H_O = 8 + 8.1 = 16.1$ FT
- $H_T + V_T = 16.1 + 4.5 = 20.6$ FT

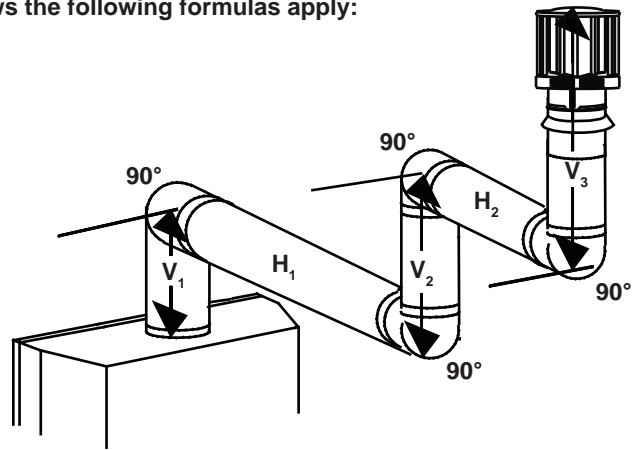

Formula 1: $H_T \leq 3V_T$
 $3V_T = 3 \times 4.5 = 13.5$ FT
 $16.1 > 13.5$

Since this formula is not met, this vent configuration is **unacceptable**.

Formula 2: $H_T + V_T \leq 40$ feet
 $20.6 \leq 40$

Since only formula 2 is met, this vent configuration is unacceptable and a new fireplace location or vent configuration will need to be established to satisfy both formulas.

18.1_2A

4.0 INSTALLATION

WARNING

FOR SAFE AND PROPER OPERATION OF THE APPLIANCE, FOLLOW THE VENTING INSTRUCTIONS EXACTLY.

ALL INNER EXHAUST AND OUTER INTAKE VENT PIPE JOINTS MAY BE SEALED USING EITHER RED RTV HIGH TEMP SILICONE SEALANT W573-0002 (NOT SUPPLIED) OR BLACK HIGH TEMP MILL PAC W573-0007 (NOT SUPPLIED) WITH THE EXCEPTION OF THE APPLIANCE EXHAUST FLUE COLLAR WHICH MUST BE SEALED USING MILL PAC.

IF USING PIPE CLAMPS TO CONNECT VENT COMPONENTS, 3 SCREWS MUST ALSO BE USED TO ENSURE THE CONNECTION CANNOT SLIP OFF.

DO NOT CLAMP THE FLEXIBLE VENT PIPE.

RISK OF FIRE, EXPLOSION OR ASPHYXIATION. IMPROPER SUPPORT OF THE ENTIRE VENTING SYSTEM MAY ALLOW VENT TO SAG AND SEPARATE. USE VENT RUN SUPPORTS AND CONNECT VENT SECTIONS PER INSTALLATION INSTRUCTIONS.

RISK OF FIRE, DO NOT ALLOW LOOSE MATERIALS OR INSULATION TO TOUCH THE VENT PIPE. REMOVE INSULATION TO ALLOW FOR THE INSTALLATION OF THE ATTIC SHIELD AND TO MAINTAIN CLEARANCES TO COMBUSTIBLES.

68.2A

4.1 WALL AND CEILING PROTECTION

WARNING

DO NOT FILL THE SPACE BETWEEN THE VENT PIPE AND ENCLOSURE WITH ANY TYPE OF MATERIAL. DO NOT PACK INSULATION OR COMBUSTIBLES BETWEEN CEILING FIRESTOPS. ALWAYS MAINTAIN SPECIFIED CLEARANCES AROUND VENTING AND FIRESTOP SYSTEMS. INSTALL WALL SHIELDS AND FIRESTOPS AS SPECIFIED. FAILURE TO KEEP INSULATION OR OTHER MATERIALS AWAY FROM VENT PIPE MAY CAUSE FIRE.

70.1

For clearances to combustible materials from the vent pipe, see "FRAMING" section.

4.1.2 HORIZONTAL INSTALLATION

! WARNING

THE FIRESTOP ASSEMBLY MUST BE INSTALLED WITH THE VENT SHIELD TO THE TOP.

TERMINALS MUST NOT BE RECESSED INTO A WALL OR SIDING MORE THAN THE DEPTH OF THE RETURN FLANGE OF THE MOUNTING PLATE.

This application occurs when venting through an exterior wall. Having determined the correct height for the air terminal location, cut and frame a hole in the exterior wall as illustrated to accommodate the firestop assembly. Dry fit the firestop assembly before proceeding to ensure the brackets on the rear surface fit to the inside surface of the horizontal framing.

The length of the vent shield may be cut shorter for combustible walls that are less than 8 1/2" thick but the vent shield must extend the full depth of the combustible wall.

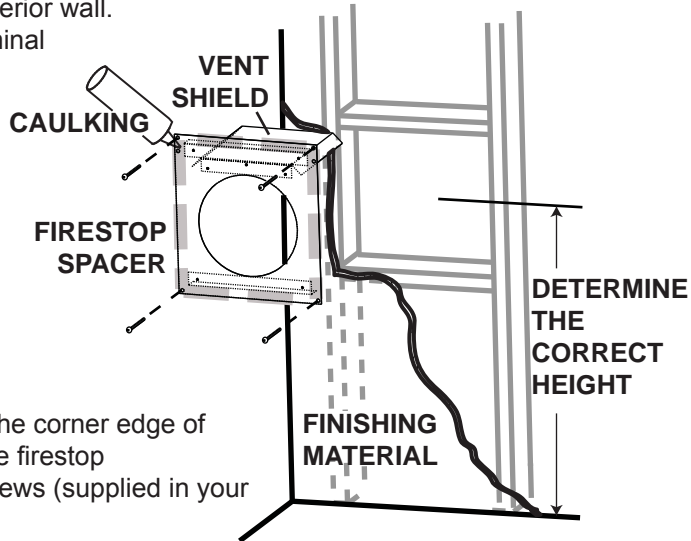

- A. Apply a bead of caulking (not supplied) around the corner edge of the inside surface of the firestop assembly, fit the firestop assembly to the hole and secure using the 4 screws (supplied in your manual baggie).
- B. Once the vent pipe is installed in its final position, apply high temperature sealant W573-0007 (not supplied) between the pipe and the firestop.

20.2

4.1.3 VERTICAL INSTALLATION

This application occurs when venting through a roof. Installation kits for various roof pitches are available from your authorized dealer / distributor. See accessories to order specific kits required.

- A. Determine the air terminal location, cut and frame a square opening as illustrated in the ceiling and the roof to provide the minimum 1" clearance between the vent pipe and any combustible material. Try to center the vent pipe location midway between two joists to prevent having to cut them. Use a plumb bob to line up the center of the openings. A vent pipe shield will prevent any materials such as insulation, from filling up the 1" air space around the pipe. Nail headers between the joist for extra support.

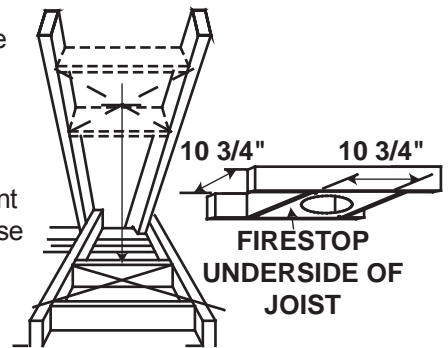

- B. Apply a bead of caulking (not supplied) to the framework or to the Wolf Steel vent pipe shield plate or equivalent (in the case of a finished ceiling), and secure over the opening in the ceiling. A firestop must be placed on the bottom of each framed opening in a roof or ceiling that the venting system passes through. Apply a bead of caulking all around and place a firestop spacer over the vent shield to restrict cold air from being drawn into the room or around the fireplace. Ensure that both spacer and shield maintain the required clearance to combustibles. Once the vent pipe is installed in its final position, apply sealant between the pipe and the firestop assembly.

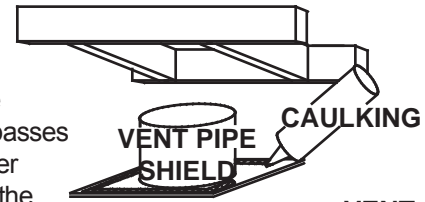

- C. In the attic, slide the vent pipe collar down to cover up the open end of the shield and tighten. This will prevent any materials, such as insulation, from filling up the 1" air space around the pipe.

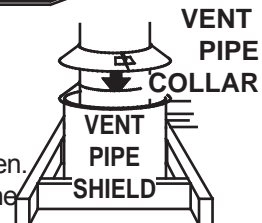

21.1

4.2 USING FLEXIBLE VENT COMPONENTS

! WARNING

DO NOT ALLOW THE INNER FLEX PIPE TO BUNCH UP ON HORIZONTAL OR VERTICAL RUNS AND ELBOWS. KEEP IT PULLED TIGHT.

SPACERS ARE ATTACHED TO THE INNER FLEX PIPE AT PREDETERMINED INTERVALS TO MAINTAIN AN EVEN AIR GAP TO THE OUTER FLEX PIPE. THIS GAP IS REQUIRED FOR SAFE OPERATION. A SPACER IS REQUIRED AT THE START, MIDDLE AND END OF EACH ELBOW TO ENSURE THIS GAP IS MAINTAINED. THESE SPACERS MUST NOT BE REMOVED.

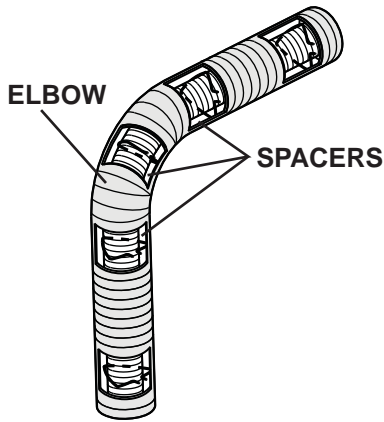

For safe and proper operation of the appliance, follow the venting instructions exactly.

All inner flex pipe and outer flex pipe joints may be sealed using high temperature sealant W573-0002 (not supplied) or the high temperature sealant W573-0007 Mill Pac (not supplied). However, the high temperature sealant W573-0007 Mill Pac (not supplied) must be used on the joint connecting the inner flex pipe and the exhaust flue collar.

Use only approved flexible vent pipe kits marked:



“Wolf Steel Approved Venting” as identified by the stamp only on the outer flex pipe.

22.1

4.2.1 HORIZONTAL AIR TERMINAL INSTALLATION

- A. Stretch the inner flex pipe to the required length taking into account the additional length needed for the finished wall surface. Slip the vent pipe a minimum of 2” over the inner sleeve of the air terminal and secure with 6 #8 screws. Apply a heavy bead of the high temperature sealant W573-0007 Mill Pac (not supplied).
- B. Using the outer flex pipe, slide over the outer combustion air sleeve of the air terminal and secure with 6 #8 screws. Seal using high temperature sealant W573-0002 (not supplied).
- C. Insert the vent pipes through the firestop maintaining the required clearance to combustibles. Holding the air terminal (lettering in an upright, readable position), secure to the exterior wall and make weather tight by sealing with caulking (not supplied).
- D. If more vent pipe needs to be used to reach the fireplace, couple them together as illustrated. The vent system must be supported approximately every 3 feet for both vertical and horizontal runs. Use noncombustible strapping to maintain the minimum 1” clearance to combustibles.

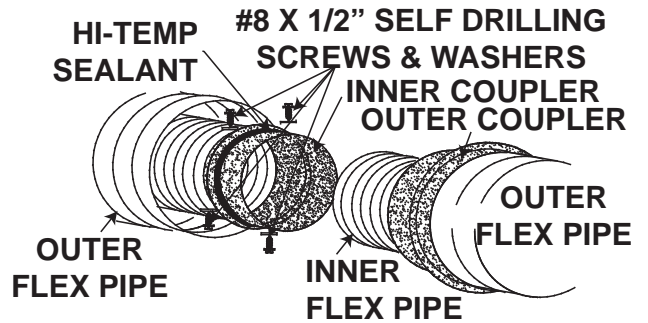
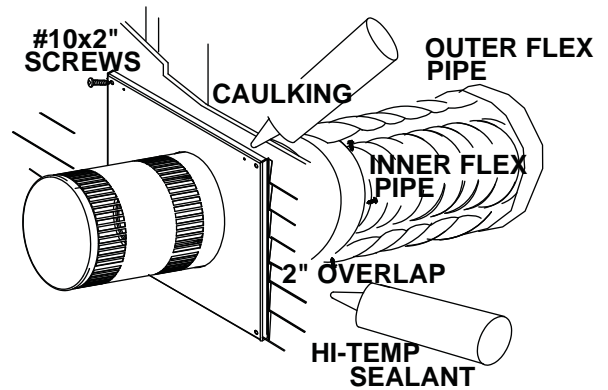

The air terminal mounting plate may be recessed into the exterior wall or siding no greater than the depth of its return flange.

23.4

4.2.2 VERTICAL AIR TERMINAL INSTALLATION

! WARNING**MAINTAIN A MINIMUM 2" SPACE BETWEEN THE AIR INLET BASE AND THE STORM COLLAR.**

- A.** Fasten the roof support to the roof using the screws provided. The roof support is optional. In this case the venting is to be adequately supported using either an alternate method suitable to the authority having jurisdiction or the optional roof support.
- B.** Stretch the inner flex pipe to the required length. Slip the inner flex pipe a minimum of 2" over the inner pipe of the air terminal connector and secure with 6 #8 screws. Seal using a heavy bead of high temperature sealant W573-0007 (not supplied).
- C.** Repeat using the outer flex pipe, using a heavy bead of high temperature sealant W573-0002 (not supplied).
- D.** Thread the air terminal connector / vent pipe assembly down through the roof. The air terminal must be positioned vertically and plumb. Attach the air terminal connector to the roof support, ensuring that the top of the air terminal is 16" above the highest point that it penetrates the roof.
- E.** Remove nails from the shingles, above and to the sides of the air terminal connector. Place the flashing over the air terminal connector leaving a min. 3/4" of the air terminal connector showing above the top of the flashing. Slide the flashing underneath the sides and upper edge of the shingles. Ensure that the air terminal connector is properly centred within the flashing, giving a 3/4" margin all around. Fasten to the roof. Do not nail through the lower portion of the flashing. Make weather-tight by sealing with caulking. Where possible, cover the sides and top edges of the flashing with roofing material.
- F.** Aligning the seams of the terminal and air terminal connector, place the terminal over the air terminal connector making sure the vent pipe goes into the hole in the terminal. Secure with the three screws provided.
- G.** Apply a heavy bead of weatherproof caulking 2" above the flashing. Install the storm collar around the air terminal and slide down to the caulking. Tighten to ensure that a weather-tight seal between the air terminal and the collar is achieved.
- H.** If more vent pipe needs to be used to reach the fireplace see "HORIZONTAL AIR TERMINAL INSTALLATION" section.

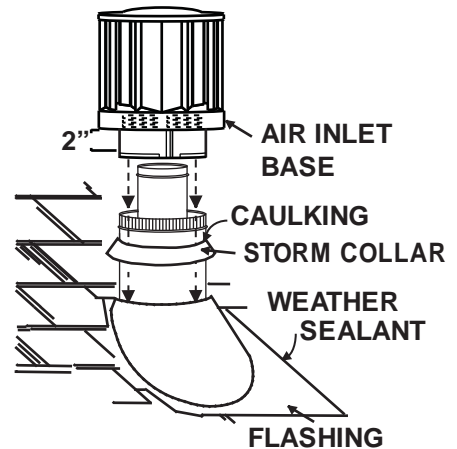
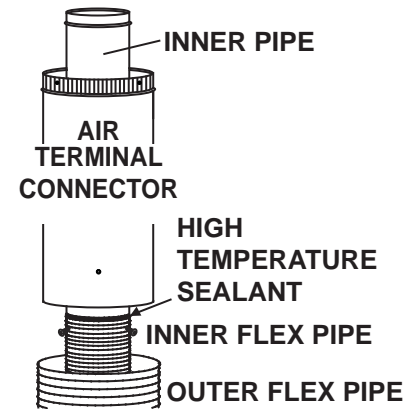
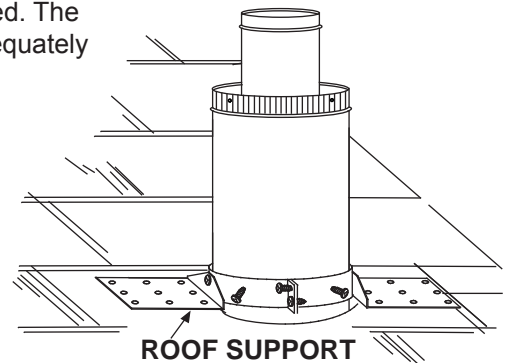

24.2

4.2.3 APPLIANCE VENT CONNECTION

- A. Install the inner flex pipe to the appliance. Secure with 3 screws and flat washers. Seal the joint and screw holes using the high temperature sealant W573-0007 (not supplied).
- B. Install the outer flex pipe to the appliance. Attach and seal the joints using the high temperature sealant W573-0002 (not supplied).

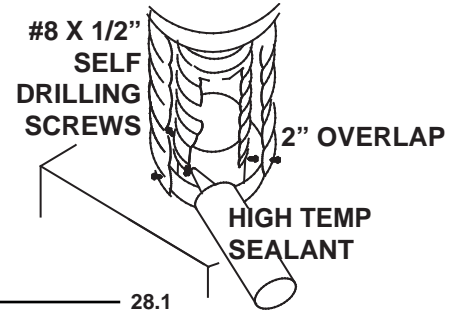

4.3 MOBILE HOME INSTALLATION

This appliance is certified to be installed as an OEM (Original Equipment Manufacturer) installation in a manufactured home or mobile home and must be installed in accordance with the manufacturer's instructions and the Manufactured Home Construction and Safety Standard, Title 24 CFR, Part 3280, in the United States or the Mobile Home Standard, CAN/CSA Z240 MH Series, in Canada. This appliance is only for use with the type(s) of gas indicated on the rating plate. A conversion kit is supplied with the mobile home appliance.

This Mobile/Manufactured Home Listed appliance comes factory equipped with a means to secure the unit. Built in appliances are equipped with 1/4" diameter holes located in the front left and right corners of the base. Use #10 hex head screws, inserted through the holes in the base to secure. For free standing products contact your local authorized dealer / distributor for the appropriate securing kit. For mobile home installations, the appliance must be fastened in place. It is recommended that the appliance be secured in all installations. Always turn off the pilot and the fuel supply at the source, prior to moving the mobile home. After moving the mobile home and prior to lighting the appliance, ensure that the logs are positioned correctly.

This appliance is certified to be installed in an aftermarket permanently located, manufactured (mobile) home, where not prohibited by local codes.
This appliance is only for use with the type of gas indicated on the rating plate. This appliance is not convertible for use with other gases, unless a certified kit is used.

Conversion Kits

This appliance is field convertible between Natural Gas (NG) and Propane (LP).
To convert from one gas to another consult your Authorized dealer/distributor.

 29.1

4.4 GAS INSTALLATION

 WARNING
RISK OF FIRE, EXPLOSION OR ASPHYXIATION. ENSURE THERE ARE NO IGNITION SOURCES SUCH AS SPARKS OR OPEN FLAMES.
SUPPORT GAS CONTROL WHEN ATTACHING GAS SUPPLY PIPE TO PREVENT DAMAGING GAS LINE.
ALWAYS LIGHT THE PILOT WHETHER FOR THE FIRST TIME OR IF THE GAS SUPPLY HAS RUN OUT WITH THE GLASS DOOR OPENED OR REMOVED. PURGING OF THE GAS SUPPLY LINE SHOULD BE PERFORMED BY A QUALIFIED SERVICE TECHNICIAN. ASSURE THAT A CONTINUOUS GAS FLOW IS AT THE BURNER BEFORE CLOSING THE DOOR. ENSURE ADEQUATE VENTILATION. FOR GAS AND ELECTRICAL LOCATIONS, SEE “DIMENSION” SECTION.
ALL GAS CONNECTIONS MUST BE CONTAINED WITHIN THE APPLIANCE WHEN COMPLETE.
HIGH PRESSURE WILL DAMAGE VALVE. DISCONNECT GAS SUPPLY PIPING BEFORE TESTING GAS LINE AT TEST PRESSURES ABOVE 1/2 PSIG.
VALVE SETTINGS HAVE BEEN FACTORY SET, DO NOT CHANGE.

Installation and servicing to be done by a qualified installer. **Do not use open flame.**

- 4.4.1 Move the appliance into position and secure.
- 4.4.2 If equipped with a flex connector the appliance is designed to accept a 1/2" gas supply. Without the connector it is designed to accept a 3/8" gas supply. The appliance is equipped with a manual shut off valve to turn off the gas supply to the appliance.
- 4.4.3 Connect the gas supply in accordance to local codes. In the absence of local codes, install to the current CAN/CSA-B149.1 Installation Code in Canada or to the current National Fuel Gas Code, ANSI Z223.1 / NFPA 54 in the United States.
- 4.4.4 When flexing any gas line, support the gas valve so that the lines are not bent or kinked.
- 4.4.5 The gas line flex-connector should be installed to provide sufficient movement for shifting the burner assembly on it's side to aid with servicing components.
- 4.4.6 Check for gas leaks by brushing on a soap and water solution.

30.1A

5.0 FRAMING

! WARNING
RISK OF FIRE!
IN ORDER TO AVOID THE POSSIBILITY OF EXPOSED INSULATION OR VAPOUR BARRIER COMING IN CONTACT WITH THE APPLIANCE BODY, IT IS RECOMMENDED THAT THE WALLS OF THE APPLIANCE ENCLOSURE BE “FINISHED” (IE: DRYWALL / SHEETROCK), AS YOU WOULD FINISH ANY OTHER OUTSIDE WALL OF A HOME. THIS WILL ENSURE THAT CLEARANCE TO COMBUSTIBLES IS MAINTAINED WITHIN THE CAVITY.
DO NOT NOTCH THE FRAMING AROUND THE APPLIANCE STAND-OFFS. FAILURE TO MAINTAIN AIR SPACE CLEARANCE MAY CAUSE OVER HEATING AND FIRE. PREVENT CONTACT WITH SAGGING OR LOOSE INSULATION OR FRAMING AND OTHER COMBUSTIBLE MATERIALS. BLOCK OPENING INTO THE CHASE TO PREVENT ENTRY OF BLOWN-IN INSULATION. MAKE SURE INSULATION AND OTHER MATERIALS ARE SECURED.
WHEN CONSTRUCTING THE ENCLOSURE ALLOW FOR FINISHING MATERIAL THICKNESS TO MAINTAIN CLEARANCES. FRAMING OR FINISHING MATERIAL CLOSER THAN THE MINIMUMS LISTED MUST BE CONSTRUCTED ENTIRELY OF NON-COMBUSTIBLE MATERIALS. MATERIALS CONSISTING ENTIRELY OF STEEL, IRON, BRICK, TILE, CONCRETE, SLATE, GLASS OR PLASTERS, OR ANY COMBINATION THEREOF ARE SUITABLE. MATERIALS THAT ARE REPORTED AS PASSING ASTM E 136, STANDARD TEST METHOD FOR BEHAVIOUR OF MATERIALS IN A VERTICAL TUBE FURNACE AT 750°C AND UL763 SHALL BE CONSIDERED NON-COMBUSTIBLE MATERIALS.
MINIMUM CLEARANCE TO COMBUSTIBLES MUST BE MAINTAINED OR A SERIOUS FIRE HAZARD COULD RESULT.
THE APPLIANCE REQUIRES A MINIMUM ENCLOSURE HEIGHT. MEASURE FROM THE APPLIANCE BASE.
IF STEEL STUD FRAMING KITS WITH CEMENT BOARD ARE PROVIDED, THEY MUST BE INSTALLED.

71.1

Your appliance can be installed with either an arched opening (FK80-A) or a rectangular opening (FK80-R) using one of the above kits.

The framing kits serve two purposes. They are necessary if optional doors (DK80) are to be installed. Secondly, they act as a reference when finishing to the fireplace opening.

The FK80 is designed to accommodate 1/2” to 1 1/2” finishing material. They are adjustable to ensure doors open fully .

If finishing material is thicker than 1 1/2”, an optional extension kit is available (EK80).

It is best to frame your appliance after it is positioned and the vent system is installed. Use 2x4's and frame to local building codes.

It is not necessary to install a hearth extension, but the appliance should be raised to be flush with either the hearth or the finished floor.

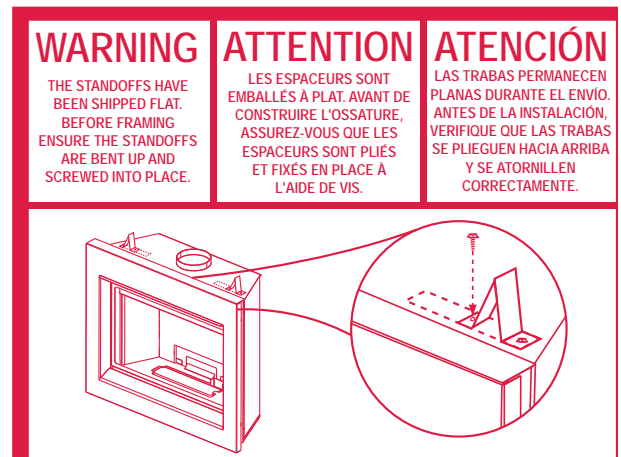

When roughing in the appliance, raise the appliance to accommodate for the thickness of the finished floor materials, i.e. tile, carpeting, hard wood, which if not planned for will interfere with the removal of the hearth strip, which must be removed to access the firebox.

If the intent is to use the Chelmsford mantel, a riser is required to lift the unit, while at the framing stage.

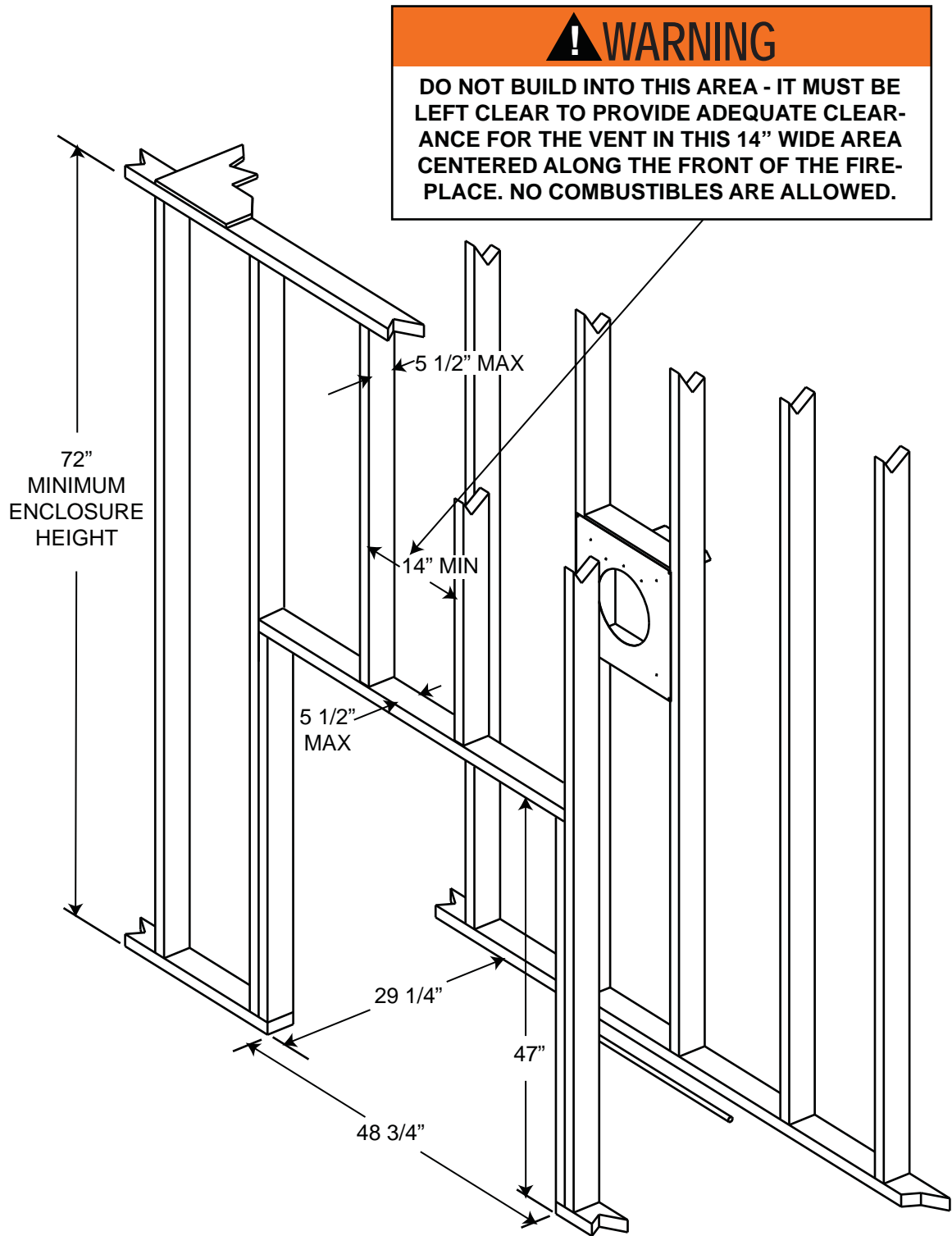

5.1 MINIMUM CLEARANCE TO COMBUSTIBLES

Minimum clearance to combustible construction from appliance and vent surfaces:	
Non combustible framing:	
Top	0" to stand-offs.
Combustible framing:	
Sides, back, bottom of the unit	0" to stand-offs
Non combustible finishing:	
Top	18" to top of appliance opening
Sides	5 3/8" to sides of appliance opening
Combustible finishing:	
Bottom	0" to bottom edge of appliance
Enclosure top	72" from the bottom of appliance
Recessed depth	29 1/4"
Vent pipe**	2" all around
Ceiling	90" from bottom of unit

****HORIZONTAL VENT SECTIONS:** A minimum clearance of 2" all around the vent pipe on all horizontal runs to combustibles is required except for clearances in appliance enclosures. Use firestop spacer W010-1800 (supplied).

****VERTICAL VENT SECTIONS:** A minimum of 1" all around the vent pipe on all vertical runs to combustibles is required except for clearances in appliance enclosures. Use firestop spacer W500-0367 (not supplied).

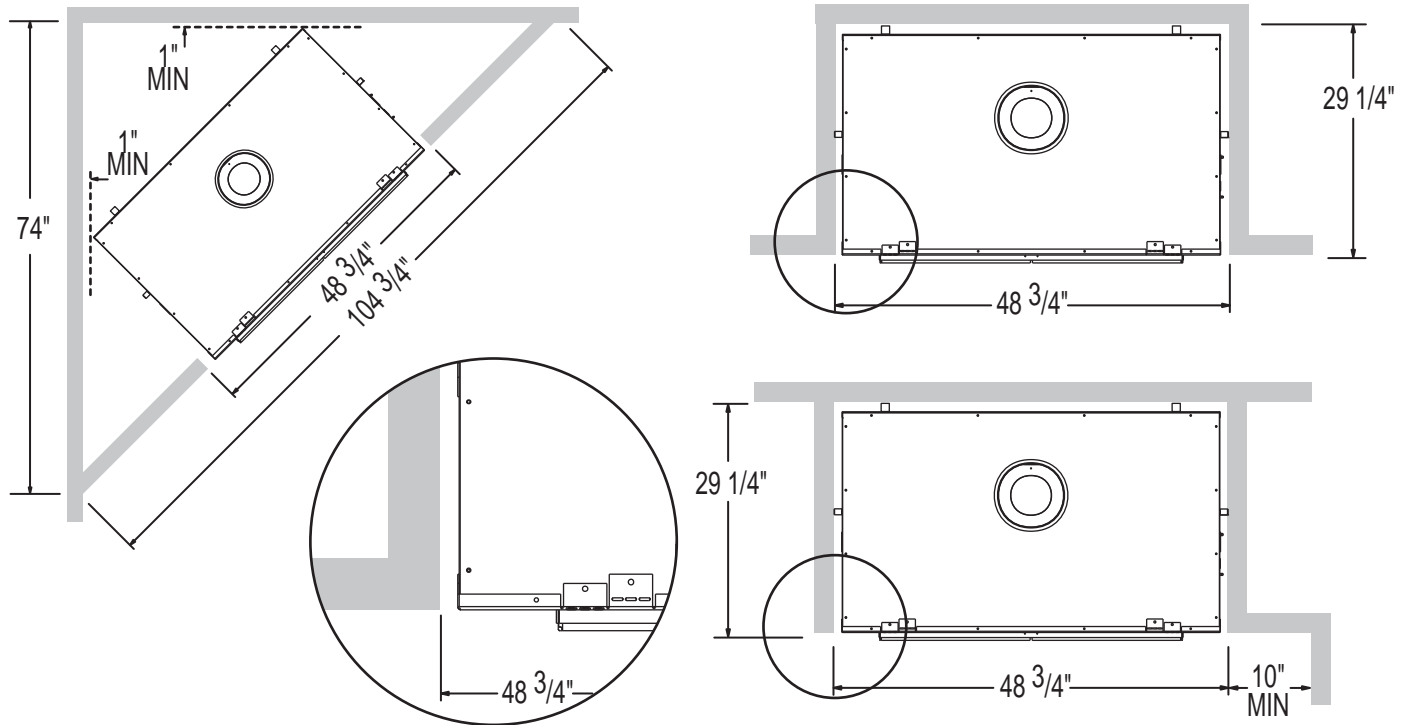

5.2 MINIMUM CLEARANCE TO COMBUSTIBLE ENCLOSURES

! WARNING

USE ONLY NON-COMBUSTIBLE MATERIAL SUCH AS CEMENT BOARD, CERAMIC TILE, MARBLE, ETC. WHEN FINISHING TO THE APPLIANCE. DO NOT USE WOOD OR DRYWALL.

FACING AND/OR FINISHING MATERIAL MUST NEVER OVERHANG INTO THE APPLIANCE OPENING

DO NOT DISTORT OR FORCE THE FRAME KIT COMPONENTS.

WHEN USING A ROUGH FINISH MATERIAL (I.E.; STONE), MAINTAIN A $\frac{1}{4}$ " - $\frac{1}{2}$ " BORDER FROM THE FRAMING COMPONENTS.

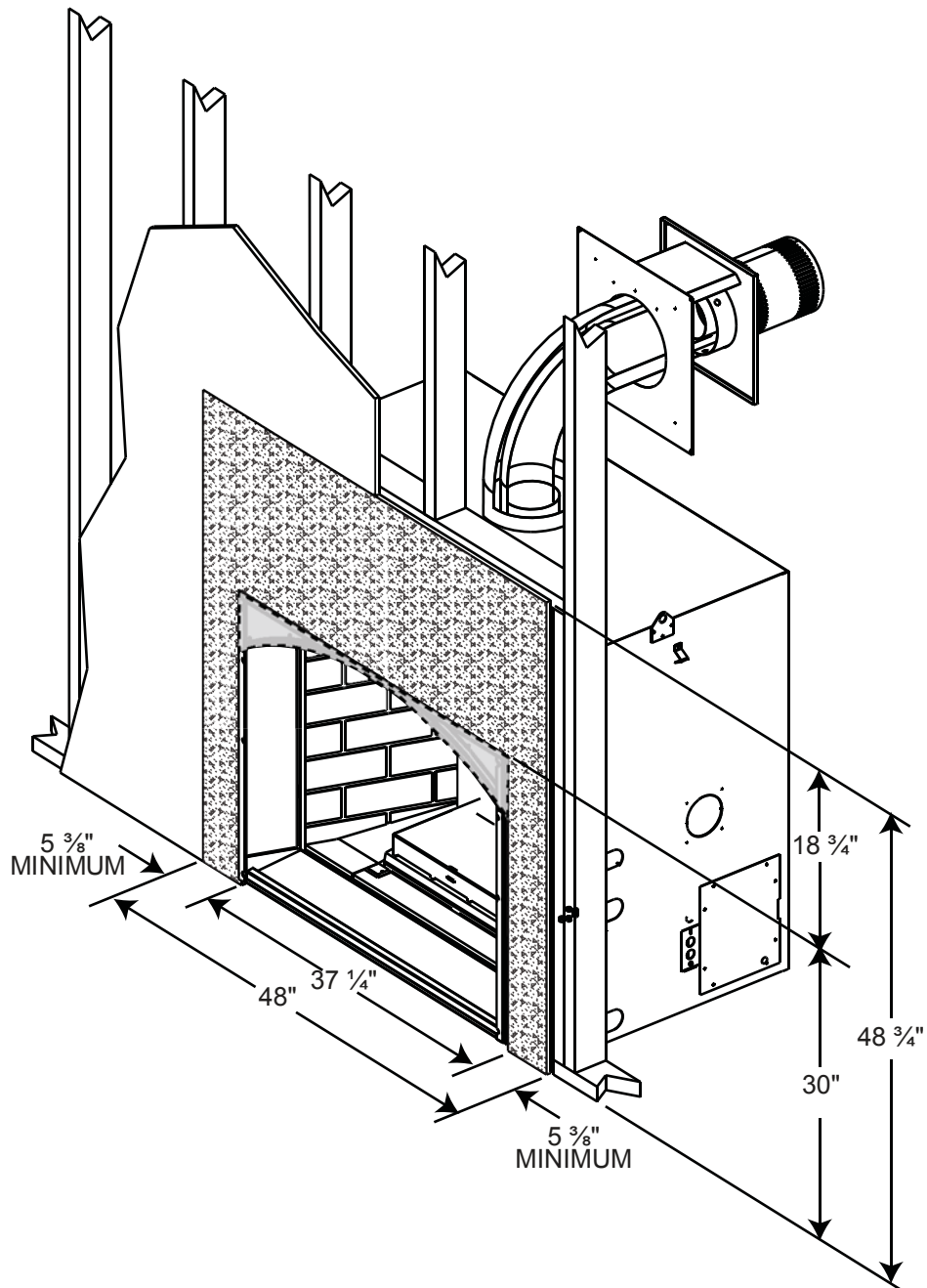
**IMPORTANT:**

Your appliance requires a minimum inside enclosure height of 72".

For temperature requirements, the enclosure space around and above the appliance must be left unobstructed.

It is recommended that the enclosure be ventilated at the top and bottom to circulate the hot air.

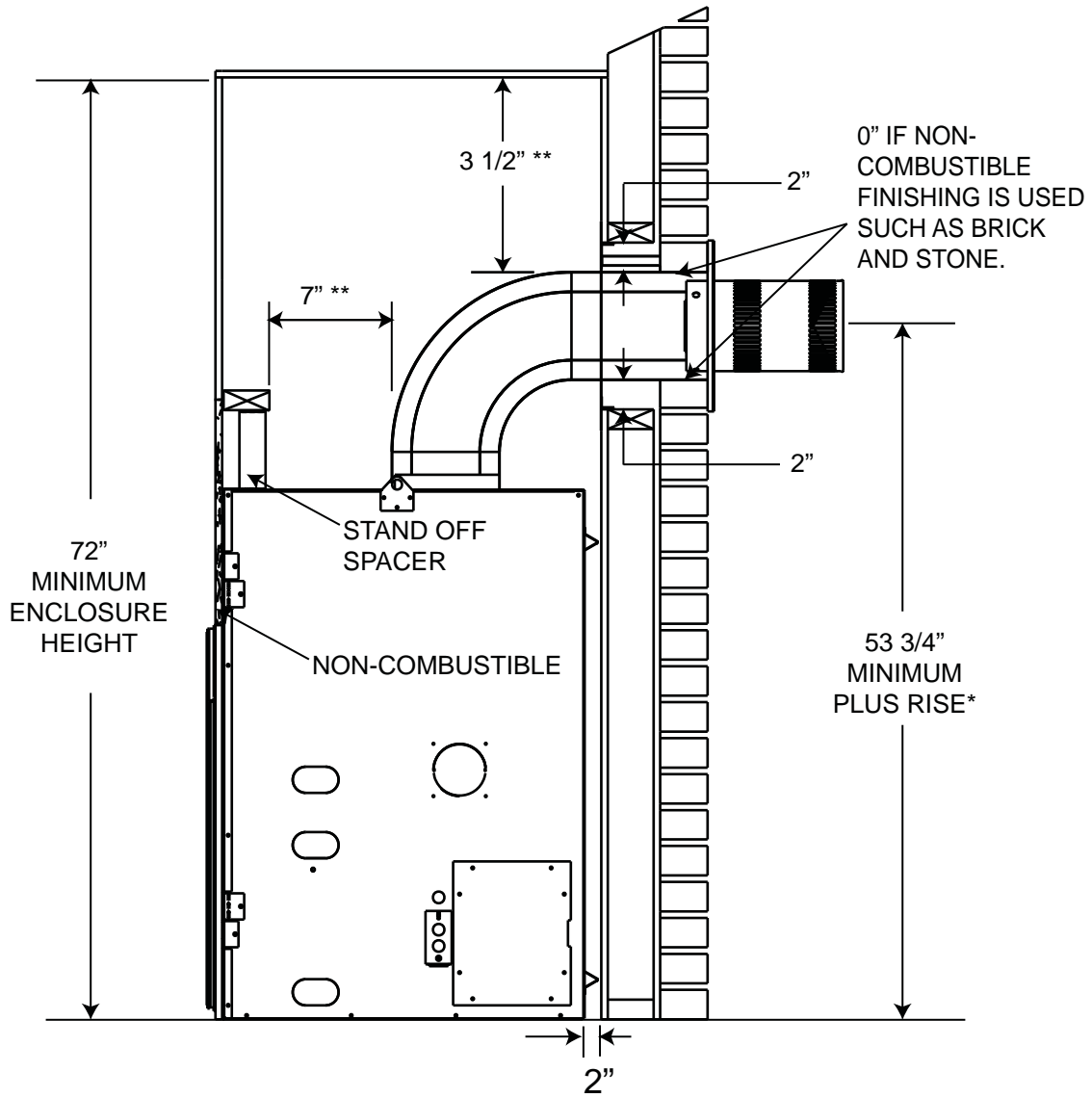

* See venting section

** Within the appliance enclosure a 7" clearance between the vertical vent run and the combustible materials on the front facing of the enclosure is required. Similarly, a 3 1/2" clearance to combustible materials from the top of the horizontal vent run is required. All other clearances within the enclosure, including where the vent pipe exits the enclosure are subject to 2" for horizontal and 1" for vertical.

5.3 MINIMUM MANTEL CLEARANCES

! WARNING

RISK OF FIRE, MAINTAIN ALL SPECIFIED AIR SPACE CLEARANCES TO COMBUSTIBLES. FAILURE TO COMPLY WITH THESE INSTRUCTIONS MAY CAUSE A FIRE OR CAUSE THE APPLIANCE TO OVERHEAT. ENSURE ALL CLEARANCES (I.E. BACK, SIDE, TOP, VENT, MANTEL, FRONT, ETC.) ARE CLEARLY MAINTAINED.

WHEN USING PAINT OR LACQUER TO FINISH THE MANTEL, THE PAINT OR LACQUER MUST BE HEAT RESISTANT TO PREVENT DISCOLOURATION.

73.1

Combustible mantel clearance can vary according to the mantel depth. Use the graph to help evaluate the clearance needed.

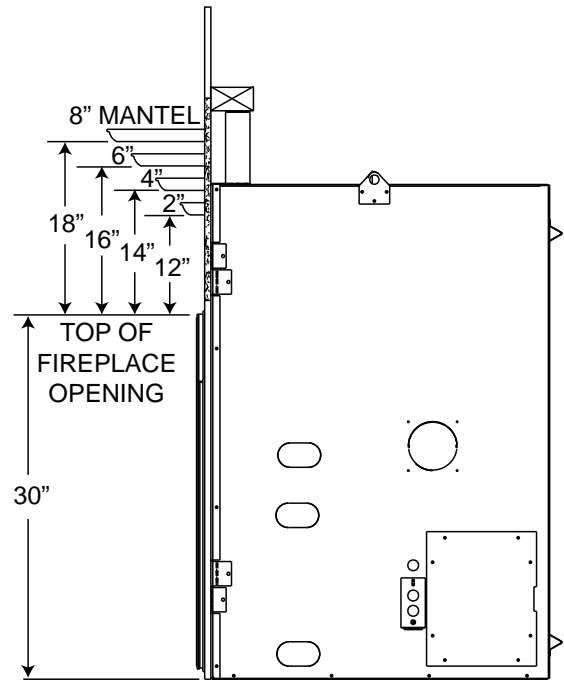
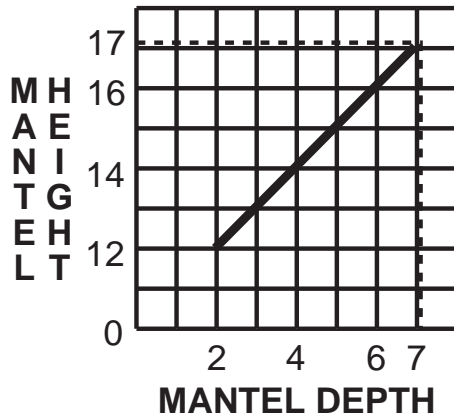

6.0 FINISHING

! WARNING
RISK OF FIRE!
NEVER OBSTRUCT THE FRONT OPENING OF THE APPLIANCE.
THE FRONT OF THE APPLIANCE MUST BE FINISHED WITH ANY NON-COMBUSTIBLE MATERIALS SUCH AS BRICK, MARBLE, GRANITE, ETC., PROVIDED THAT THESE MATERIALS DO NOT GO BELOW THE SPECIFIED DIMENSION AS ILLUSTRATED.
DO NOT STRIKE, SLAM OR SCRATCH GLASS. DO NOT OPERATE APPLIANCE WITH GLASS REMOVED, CRACKED, BROKEN OR SCRATCHED.
FACING AND/OR FINISHING MATERIAL MUST NEVER OVERHANG INTO THE APPLIANCE OPENING.

72.1A

6.1 DOOR REMOVAL / INSTALLATION

! WARNING
GLASS MAY BE HOT, DO NOT TOUCH GLASS UNTIL COOLED.
THE DOOR LATCHES ARE PART OF A SAFETY SYSTEM AND MUST BE PROPERLY ENGAGED. DO NOT OPERATE THE APPLIANCE WITH LATCHES DISENGAGED.
FACING AND/OR FINISHING MATERIALS MUST NOT INTERFERE WITH AIR FLOW THROUGH AIR OPENINGS, LOUVRES OPENINGS, OPERATION OF LOUVRES OR DOORS OR ACCESS FOR SERVICE. OBSERVE ALL CLEARANCES WHEN APPLYING COMBUSTIBLE MATERIALS.
BEFORE DOOR IS REMOVED TURN THE APPLIANCE OFF AND WAIT UNTIL APPLIANCE IS COOL TO THE TOUCH. DOORS ARE HEAVY AND FRAGILE SO HANDLE WITH CARE.

75.1

Before the glass door can be removed, the control doors, the screen assembly and the hearth strip must be removed.

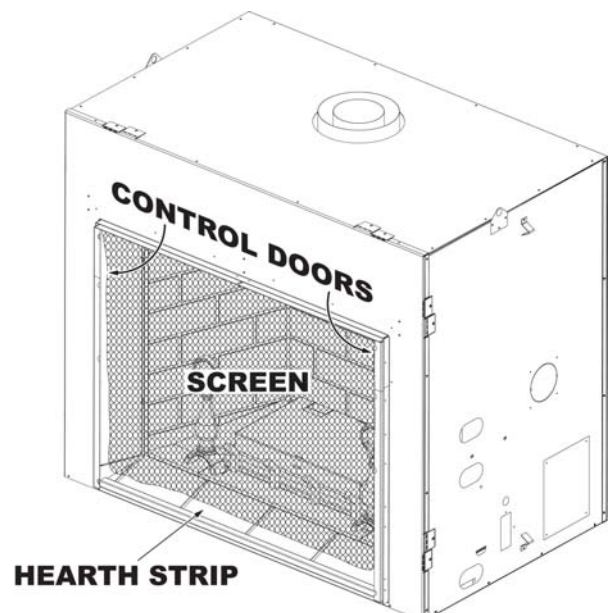

The curtain assembly can be removed by lifting the rod out from the three hooks at the top inside edge of the door opening. Lift the hearth strip up and away from the front of the appliance.

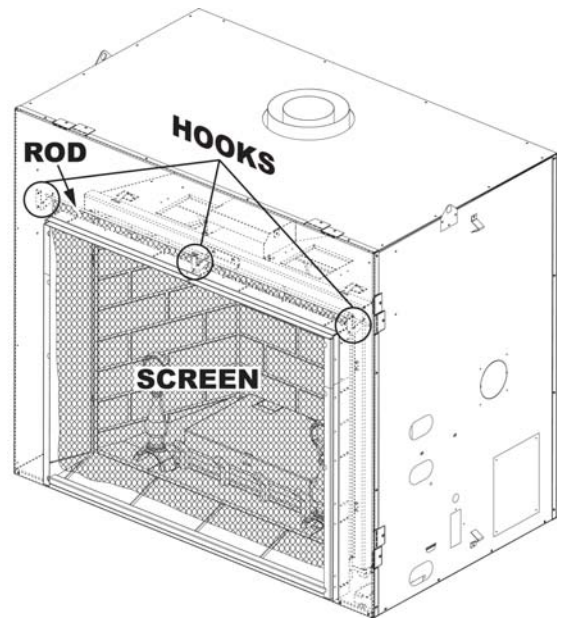

The glass door is secured to the top front edge of the firebox. Pull the handle of the latch forward, then lift the hook out from the slot in the door frame to release the top of the door. Lift the door out from the retainer along the bottom of the door using the top and bottom handles. Pull the bottom edge of the door out from the appliance until the top will pivot forward.

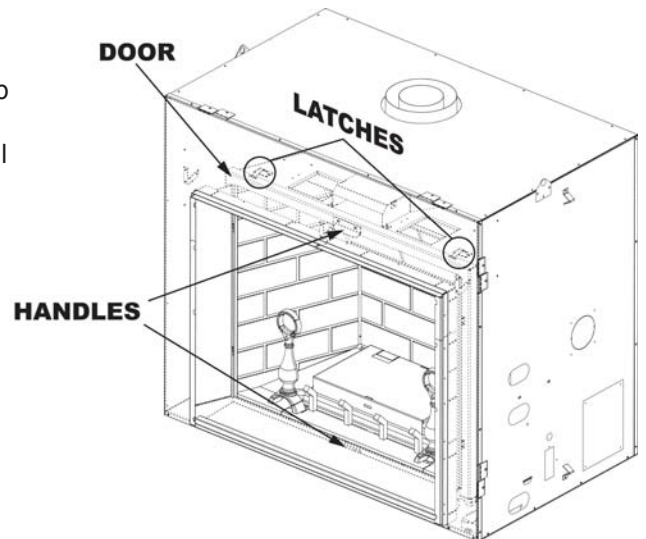

6.2 LOG SHIPPING BRACKET

Before installing the logs, you must first remove the log shipping bracket. Lift up to remove.

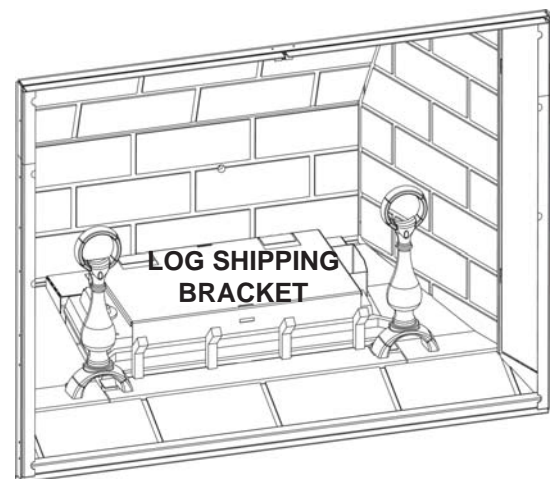

6.3 DECORATIVE BRICK PANEL INSTALLATION

6.3.1 Remove the hearth strip / screen assembly and glass door. (Refer to leaflet).

6.3.2 Remove the andiron / grate assembly by removing the 2 screws located behind the andirons.

6.3.3 Remove the right log bracket, as shown. Note the position of the securing screw in the bracket.

6.3.4 Install the right, left and centre hearth bricks into the firebox, as illustrated. The hearth should appear seamless across the front. Ensure that a 1/4" space exists between the hearth bricks and the perimeter of the burner.

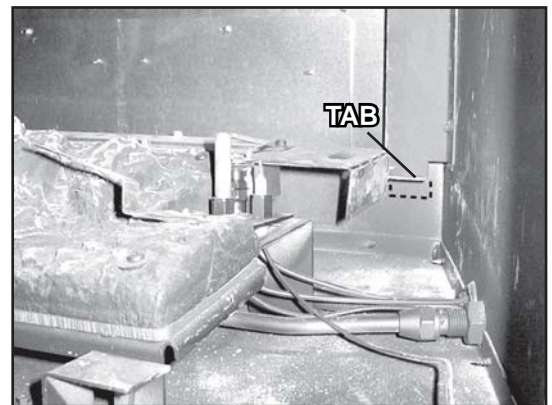
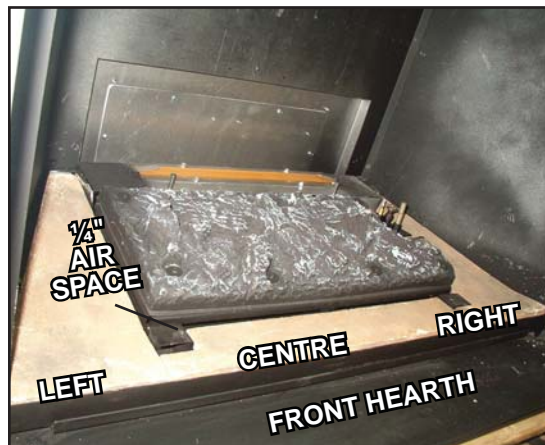

6.3.5 Ensure that the tabs, located on the back wall of the firebox, have been bent forward horizontally.

6.3.6 Install the panels in the following order:

- A - RIGHT
- B - REAR
- C - LEFT
- D - BAFFLE

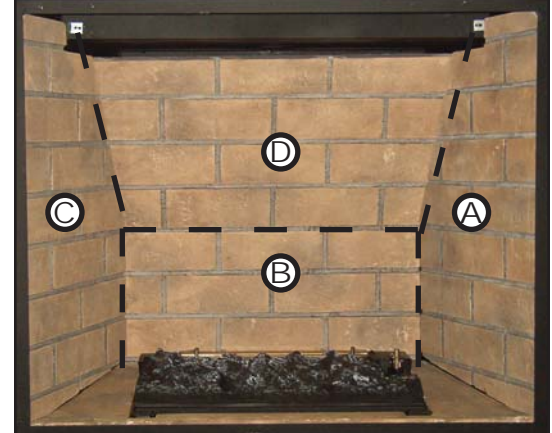

6.3.7 Secure the side panel using the retainers located in the top left and right corners of the firebox.

6.3.8 Replace the components removed in steps 2 - 3.

6.3.9 Remove one end of the hearth assembly so that the three front concrete hearth pieces can be inserted, then replace the end.



6.4 LOG PLACEMENT

! WARNING

FAILURE TO POSITION THE LOGS IN ACCORDANCE WITH THESE DIAGRAMS OR FAILURE TO USE ONLY LOGS SPECIFICALLY APPROVED WITH THIS APPLIANCE MAY RESULT IN PROPERTY DAMAGE OR PERSONAL INJURY.

LOGS MUST BE PLACED IN THEIR EXACT LOCATION IN THE APPLIANCE. DO NOT MODIFY THE PROPER LOG POSITIONS, SINCE APPLIANCE MAY NOT FUNCTION PROPERLY AND DELAYED IGNITION MAY OCCUR.

THE LOGS ARE FRAGILE AND SHOULD BE HANDLED WITH CARE.

76.1A

Phazer™ logs, exclusive to Wolf Steel Ltd. Fireplaces, provide a unique and realistic glowing effect that is different in every installation. Log colors may vary. During the initial use of the appliance, the colors will become more uniform as color pigments burn in during the heat activated curing process.

Positioning the logs improperly will cause flame impingement and carboning.

Blocked burner ports can cause an incorrect flame pattern, carbon deposits and delayed ignition. **PHAZER™** logs glow when exposed to direct flame. Use only certified **PHAZER™** logs available from your Authorized dealer.

NOTE: The logs are fuel specific. Do not interchange. Refer to the replacement parts list.

- 6.4.1** Place the rear log #1 onto the locating studs along the back edge of the PHAZERAMIC™ burner.

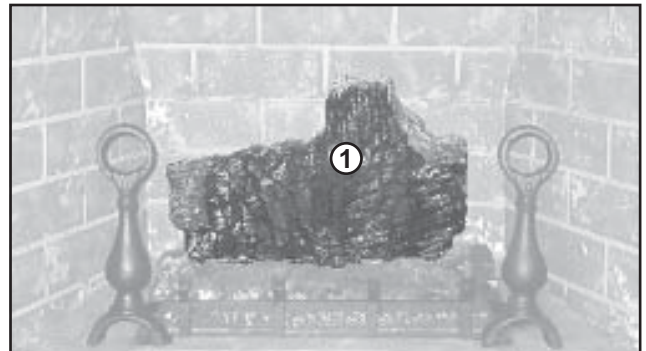

- 6.4.2** Position log #2 onto the locators on the PHAZERAMIC™ burner.

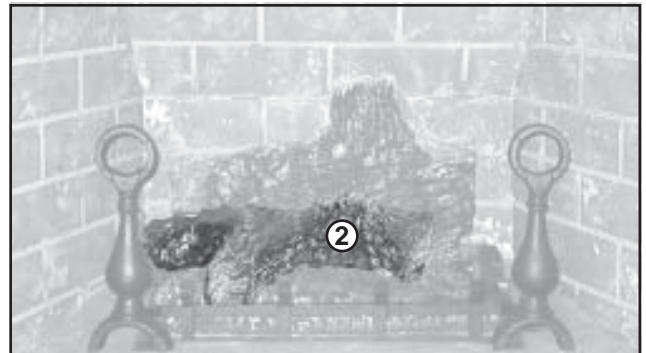

- 6.4.3** Position the slot on the bottom of log #3 onto the bracket shown with the charred face of the log to the front.



NOTE: For propane, remove the screw from the #3 log support bracket. Move the bracket to the right most location, then install the log.

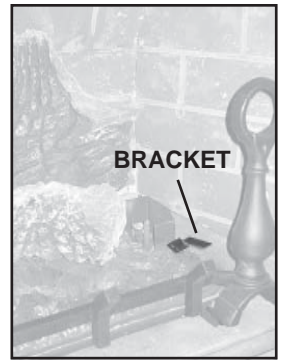

- 6.4.4** Place log #4, with the charred branch pointed inward. Locate the pins into the holes in log#1 and log#2, this will hold the rear log in position.



- 6.4.5** Place the end of log #5 on the right end of log #1. The fork in the log should straddle the knot on top of log #2.

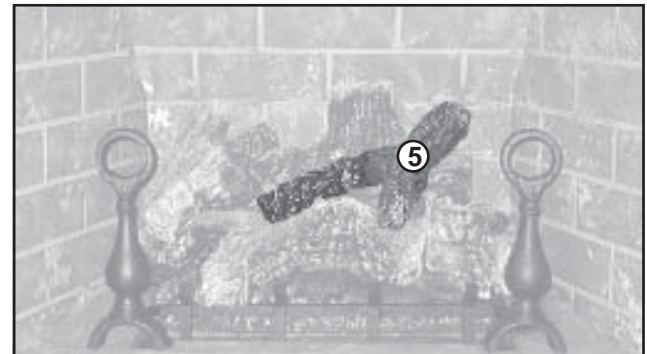

- 6.4.6** Replace the glass door and screen assembly.

6.5 GLOWING EMBERS

Glowing embers are NOT recommended. The burner has been designed to achieve maximum glow without embers.

6.6 CHARCOAL EMBERS

Randomly place the charcoal embers along the front and sides of the log support tray in a realistic manner.

Fine dust found in the bottom of the bag should not be used.

NOTE: Charcoal embers are not to be placed on the burner.

7.0 OPERATION

! WARNING

IF YOU DO NOT FOLLOW THESE INSTRUCTIONS EXACTLY, A FIRE OR EXPLOSION MAY RESULT CAUSING PROPERTY DAMAGE, PERSONAL INJURY OR LOSS OF LIFE.

ALWAYS LIGHT THE PILOT WHETHER FOR THE FIRST TIME OR IF THE GAS SUPPLY HAS RUN OUT WITH THE GLASS DOOR OPENED OR REMOVED.

7.1 GENERAL TRANSMITTER LAYOUT

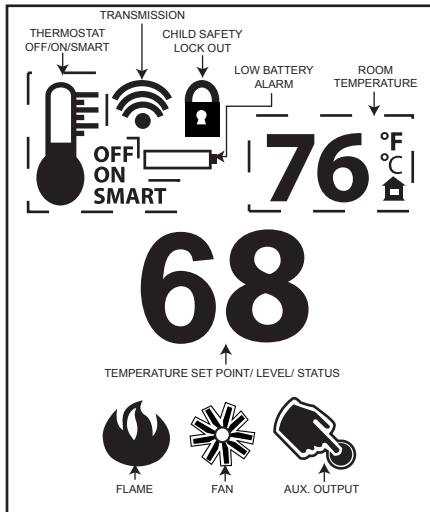

35.1

7.2 APPLIANCE OPERATION

- 7.2.1** Install 4 AA batteries into the receiver battery bay as indicated on the battery cover (+/-). (Only required as back up to household electricity). While there is a provision to connect a 6V battery pack (do not use a 9 volt battery), it must not be used when using the remote control receiver.
- 7.2.2** Place the 3 position slider switch in the “Remote” position.
- 7.2.3** Using the end of a paper clip, or other similar object, insert the end of the paper clip into the hole marked “PRG” on the receiver front cover. The receiver will “beep” three (3) times to indicate that it is ready to synchronize with the transmitter.
- 7.2.4** Install the 3 AAA batteries in the transmitter battery bay, located on the base of the transmitter. With the batteries already installed in the transmitter, push the “ON” button. The receiver will “beep” four times to indicate the transmitter’s command is accepted and set to the particular code of that transmitter. The system is now initialized.

35.2

7.3 HAND HELD REMOTE OPERATIONS

- 7.3.1** Press the ON/OFF key on the transmitter. The transmitter display will show all active icons on the screen. A single “beep” from the receiver will confirm reception of the command.

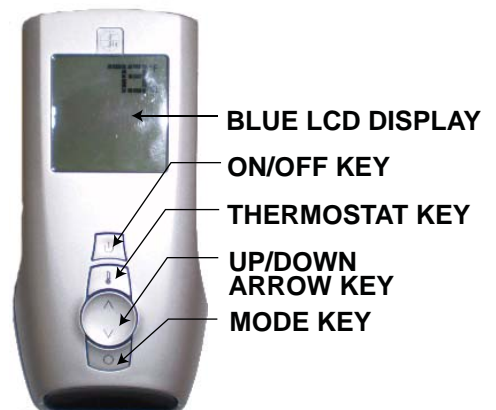

35.4

7.4 TEMPERATURE DISPLAY

7.4.1 With the system in the “OFF” position, press the Thermostat Key and the Mode Key at the same time to change from degrees F to C.

7.4.2 Look at the LCD screen on the Transmitter to verify that a C or F is visible to the right of the Room Temperature display.

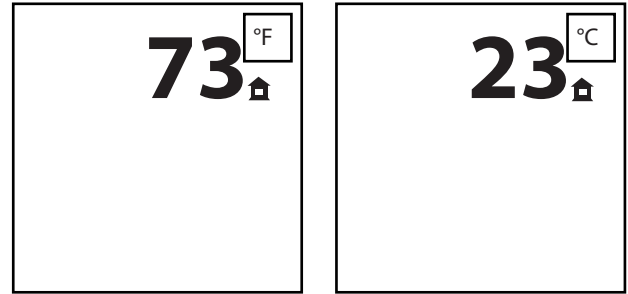

 35.5

7.5 ROOM THERMOSTAT

The remote transmitter can operate as a room thermostat. The thermostat can be set to a desired temperature to control the comfort level in the room.

7.5.1 Press the Thermostat Key. The LCD display on the Transmitter will show that the room is “ON” and the set temperature is now displayed.

7.5.2 To adjust the set temperature, press the Up/Down Arrow Keys until the desired set temperature is displayed on the LCD screen of the Transmitter.

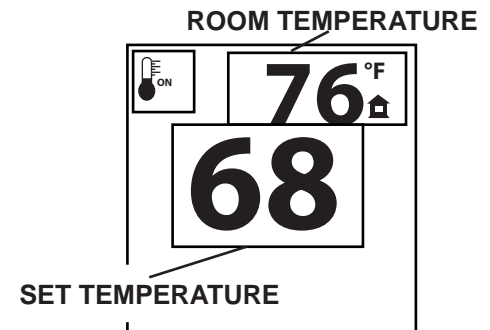

 35.6

7.6 SMART THERMOSTAT

The Smart Thermostat function adjusts the flame height according to the difference between the set temperature and the actual room temperatures. As the room temperature gets closer to the set point the Smart Function will automatically adjust the flame down.

7.6.1 Press the thermostat key until the word “SMART” appears to the right of the temperature bulb graphic.

7.6.2 To adjust the set temperature, press the Up/Down arrow keys until the desired set temperature is displayed on the LCD screen at the Transmitter.

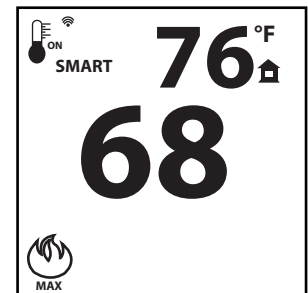

 35.7

7.7 FLAME HEIGHT

The remote control has six (6) flame levels. With the system on and the flame level at the maximum, press the Down Arrow Key once and it will reduce the flame height by one step until the flame is turned off.

The Up Arrow Key will increase the flame height each time it is pressed. If the Up Arrow Key is pressed while the system is on but the flame is off, the flame will come on the high position. A single “beep” will confirm reception of the command.

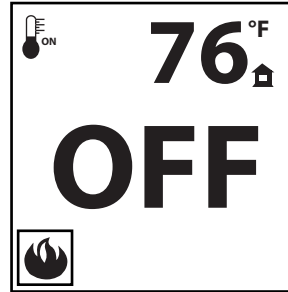

FLAME OFF

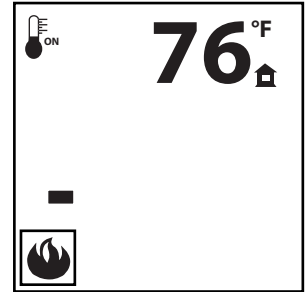

FLAME AT LEVEL 1

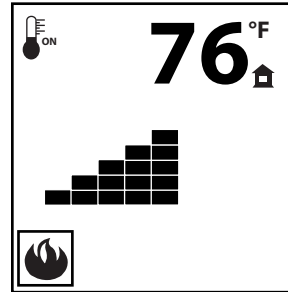

FLAME AT LEVEL 5

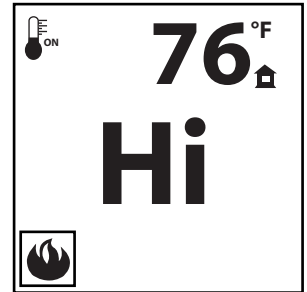

FLAME AT "HI" LEVEL 6

35.8

7.8 FAN SPEED

If the appliance is equipped with a hot air circulating fan, the speed of the fan can be controlled by the remote system. The fan speed can be adjusted through six (6) speeds.

- 7.8.1** Use the Mode key to guide you to the fan control icon.
- 7.8.2** Use the Up/Down Arrow keys to turn ON/OFF or adjust the fan speed. A single “beep” will confirm reception of the command.

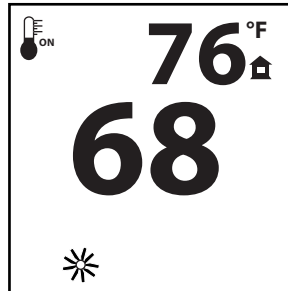

35.9

7.9 CHILD PROOF FUNCTION

This function will lock the keys to avoid unsupervised operation.

- 7.9.1** Press the MODE and UP keys at the same time.
- 7.9.2** To de-activate this function, press the MODE and UP keys at the same time.

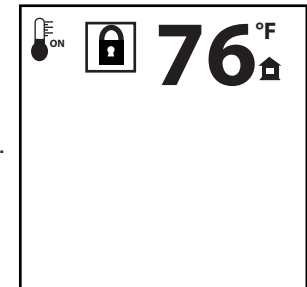

35.10

7.10 NIGHT LIGHTS™

The auxiliary function controls the AUX power outlet on the Control Module which controls the NIGHT LIGHT™.

- 7.10.1 Use the Mode Key to guide you to the AUX icon.
- 7.10.2 Pressing the Up Arrow Key will activate the NIGHT LIGHT™.
- 7.10.3 Pressing the Down Arrow Key will turn the NIGHT LIGHT™ off. A single “beep” will confirm the reception of the command.

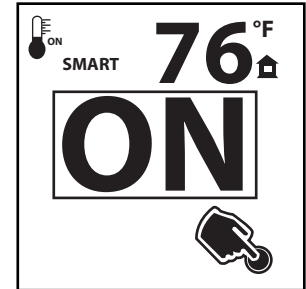
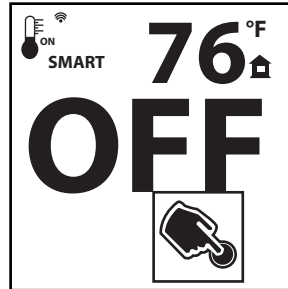

35.12

7.11 LOW BATTERY / MANUAL BYPASS

The life span of the remote batteries depends on various factors: quality of the batteries, the number of ignitions, the number of charges to the room thermostat set point, etc.

When the transmitter batteries are low, a Battery Icon will appear on the LCD display before all battery power is lost. When the batteries are replaced this icon will disappear.

Not applicable when plugged into 110V.

When the receiver batteries are low, no “beep” will be emitted from the receiver when it receives an ON/OFF command. This is an alert for the receiver that there’s low battery. When the batteries are replaced the “beep” will be emitted from the receiver when the ON/OFF key is pressed.

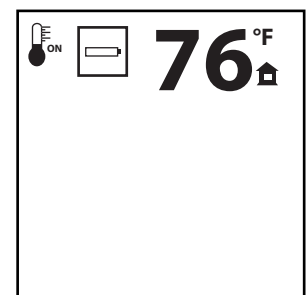

If the batteries of the receiver or transmitter are low, the appliance can be turned on manually by sliding the three position slider switch on the receiver to the “ON” position. This will bypass the remote control feature and the appliance main burner will come on if the gas valve is in the “ON” position.

35.13

7.12 IN THE EVENT OF A POWER FAILURE

If the receiver is equipped with batteries they will enable flame height control, ON/OFF or thermostat function to control the fireplace during a power failure. Refer to “FIREPLACE OPERATION” section when communications between receiver and transmitter have been lost. The will receiver emit a “beep” sound to confirm programming has been successful once power is restored. During a power failure, if the fireplace was on, the flame height will stay at the setting prior to the failure. If off when the failure occurs and then turned on, the flame height will come on at “HI”. The flame height can then be controlled by the remote.

35.14

7.13 CONTROL MODULE

Control module offers the added ability to control the fan speed through six (6) speeds, a remotely actuated 120V AUX outlet for the NIGHT LIGHT™ and a constantly powered 120V outlet.

NOTE: Control module ON/OFF switch should always be in the “ON” position. If for any reason the module is turned “OFF”, the components plugged into the module won’t have power.

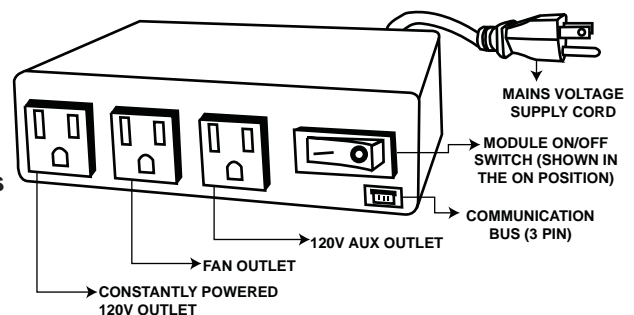

35.15

8.0 ELECTRICAL INFORMATION

! **WARNING**

DO NOT USE THIS APPLIANCE IF ANY PART HAS BEEN UNDER WATER. CALL A QUALIFIED SERVICE TECHNICIAN IMMEDIATELY TO HAVE THE APPLIANCE INSPECTED FOR DAMAGE TO THE ELECTRICAL CIRCUIT.

RISK OF ELECTRICAL SHOCK OR EXPLOSION. DO NOT WIRE 110V TO THE VALVE OR TO THE APPLIANCE WALL SWITCH. INCORRECT WIRING WILL DAMAGE CONTROLS.

ALL WIRING SHOULD BE DONE BY A QUALIFIED ELECTRICIAN AND SHALL BE IN COMPLIANCE WITH LOCAL CODES. IN THE ABSENCE OF LOCAL CODES, USE THE CURRENT CSA22.1 CANADIAN ELECTRIC CODE IN CANADA OR THE CURRENT NATIONAL ELECTRIC CODE ANSI/NFPA NO. 70 IN THE UNITED STATES.

ALWAYS LIGHT THE PILOT WHETHER FOR THE FIRST TIME OR IF THE GAS SUPPLY HAS RAN OUT, WITH THE GLASS DOOR OPENED OR REMOVED.

69.2

NOTE: If access to the control area is necessary BEFORE INSTALLATION, remove the access panel. The access panel must be re-installed before operating the unit.

8.1 HARD WIRING CONNECTION

It is necessary to hard wire this appliance. Permanently framing the appliance with an enclosure, requires the appliance junction box to be hardwired. This appliance must be electrically connected and grounded in accordance with local codes. In the absence of local codes, use the current CSA C22.1 Canadian electrical code in Canada or the ANSI/NFPA 70-1996 national electrical code in the United States.

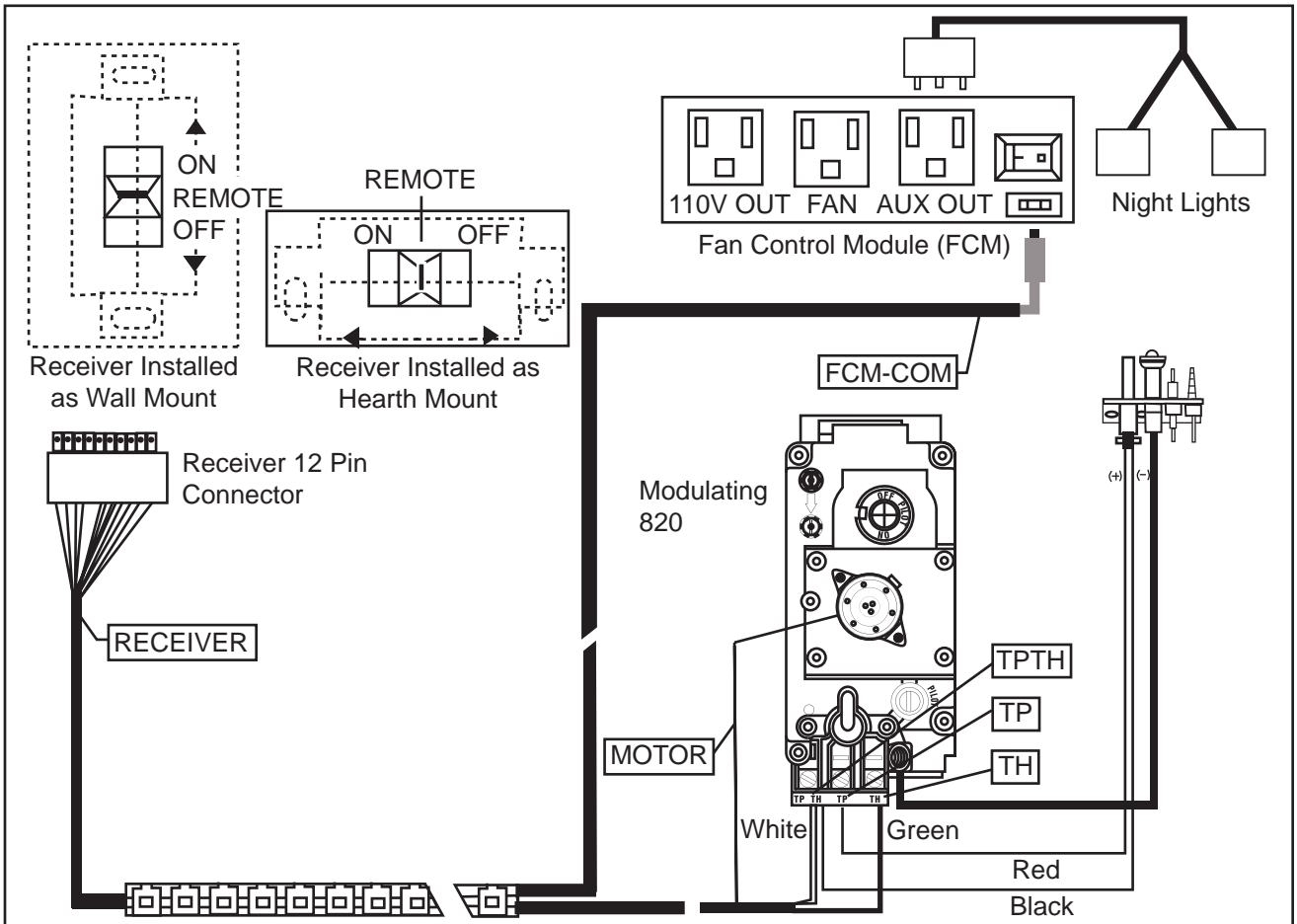

9.0 OPERATING INSTRUCTIONS

! WARNING

IF YOU DO NOT FOLLOW THESE INSTRUCTIONS EXACTLY, A FIRE OR EXPLOSION MAY RESULT CAUSING PROPERTY DAMAGE, PERSONAL INJURY OR LOSS OF LIFE.

ALWAYS LIGHT THE PILOT WHETHER FOR THE FIRST TIME OR IF THE GAS SUPPLY HAS RUN OUT WITH THE GLASS DOOR OPENED OR REMOVED.

Ensure that a continuous gas flow is at the burner before installing the door. When lit for the first time, the fireplace will emit an odor for a few hours. This is a normal temporary condition caused by the "burn-in" of paints and lubricants used in the manufacturing process and will not occur again. After extended periods of non-operation such as following a vacation or a warm weather season, the fireplace may emit a slight odor for a few hours. This is caused by dust particles in the heat exchanger burning off. In both cases, open a window to sufficiently ventilate the room.

FOR YOUR SAFETY READ BEFORE LIGHTING:

- A. This fireplace is equipped with a pilot which must be lit by hand while following these instructions exactly.
- B. Before operating smell all around the fireplace area for gas and next to the floor because some gas is heavier than air and will settle on the floor.
- C. Use only your hand to turn the gas control knob. Never use tools. If the knob will not turn by hand, do not try to repair it. Call a qualified service technician. Force or attempted repair may result in a fire or explosion.
- D. Do not use this fireplace if any part has been under water. Immediately call a qualified service technician to inspect the fireplace and replace any part of the control system and any gas control which has been under water.

WHAT TO DO IF YOU SMELL GAS:

- Turn off all gas to the fireplace.
- Open windows.
- Do not try to light any appliance.
- Do not touch any electric switch; do not use any phone in your building.
- Immediately call your gas supplier from a neighbor's phone. Follow the gas supplier's instructions.
- If you cannot reach your gas supplier, call the fire department.



LIGHTING INSTRUCTIONS

Do not connect valve or wall switch to electricity. See installation instructions.

When lighting and re-lighting, the gas knob cannot be turned from pilot to off unless the knob is depressed slightly.

1. **STOP!** Read the safety information on the operating label.
2. Turn off all electric power to the fireplace.
3. Turn the gas knob clockwise to off.
4. Wait 5 minutes to clear out any gas. If you smell gas, including near the floor, STOP! Follow "B" on the operating label. If you don't smell gas, go to the next step.
5. If the fireplace is equipped with a flame adjustment valve, turn clockwise to off.
6. Find pilot located in front of the back log on the right.
7. Turn gas knob clockwise to pilot.
8. This unit is equipped with an auto-spark. Depress and hold gas knob. Keep knob fully depressed for one minute, then release. If pilot does not continue to burn repeat steps 3 through 7.
9. With pilot lit, push and turn gas knob counter-clockwise to on.
10. If equipped with flame adjustment valve, turn knob to high.
11. If equipped with remote on-off switch, main burner may not come on when you turn the valve to on or high. Remote switch must be in the on position to ignite burner.
12. Turn on all electric power to the fireplace.

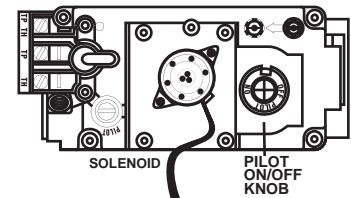

TO TURN OFF GAS

TURN OFF THE GAS AND ELECTRICAL POWER BEFORE SERVICING THE FIREPLACE.

1. Turn off all electric power to the fireplace if service is to be performed.
2. For a complete shut-down procedure: push in gas control knob slightly and turn clockwise to off. Do not force.
3. For a temporary shut-down procedure: set the switch to off. Press and turn the gas knob clockwise to pilot.

10.0 ADJUSTMENT

10.1 PILOT BURNER ADJUSTMENT

Adjust the pilot screw to provide properly sized flame. Turn in a clockwise direction to reduce the gas flow.

Inlet pressure can be checked by turning screw (A) counter-clockwise until loosened and then placing pressure gauge tubing over the test point. Gauge should read 7" (minimum 4.5") water column for natural gas or 13" (11" minimum) water column for propane. Check that main burner is operating on "HI".

Outlet pressure can be checked the same as above using screw (B). Gauge should read 3.5" water column for natural gas or 10" water column for propane. Check that main burner is operating on "HI".

AFTER TAKING PRESSURE READINGS, TIGHTEN SCREWS FIRMLY TO SEAL. DO NOT OVER TORQUE. LEAK TEST.

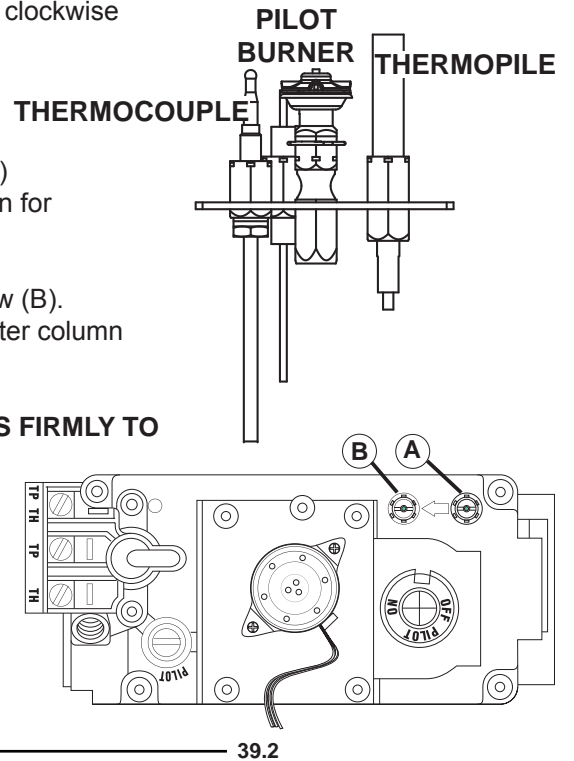

10.2 VENTURI ADJUSTMENT

This appliance has an air shutter that has been factory set open according to the chart below:

Regardless of venturi orientation, closing the air shutter will cause a more yellow flame, but can lead to carboning. Opening the air shutter will cause a more blue flame, but can cause flame lifting from the burner ports. The flame may not appear yellow immediately; allow 15 to 30 minutes for the final flame color to be established.

AIR SHUTTER ADJUSTMENT MUST ONLY BE DONE BY A QUALIFIED INSTALLER!

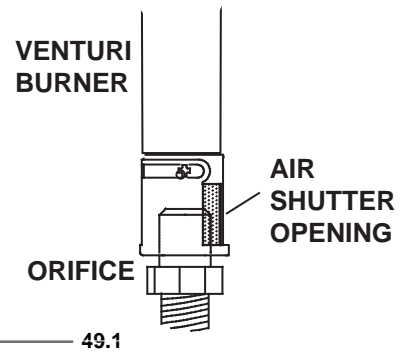

Air Shutter Openings	
LP	3/8"
NG	3/16"

10.3 FLAME CHARACTERISTICS

It's important to periodically perform a visual check of the pilot and burner flames. Compare them to the illustrations provided. If any flames appear abnormal call a service person.

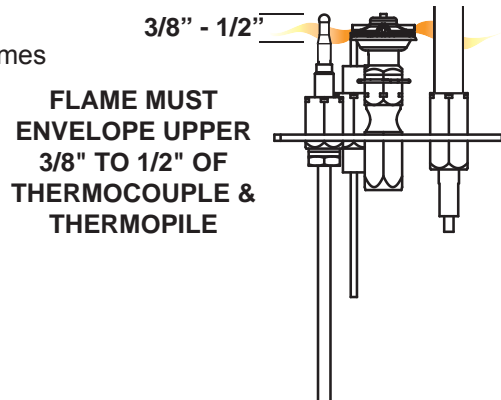
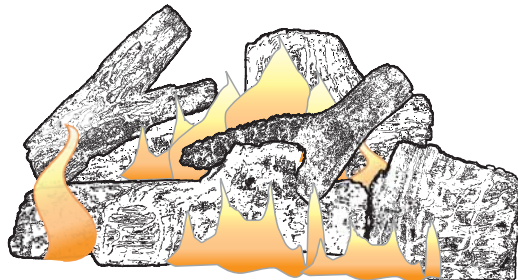

54.2

10.4 AIR CONTROL ROD ACCESS

- 10.4.1 Remove the glass door.
- 10.4.2 Remove the logs.
- 10.4.3 Remove the air deflector / light housing (It is not necessary to disconnect the wires. The assembly can lay along the right side of the firebox).
- 10.4.4 The air control rod can now be adjusted. Pushing the rod towards the back will open the air shutter (larger hole, larger opening), pulling the rod towards the front will close the shutter (smaller hole, smaller opening).

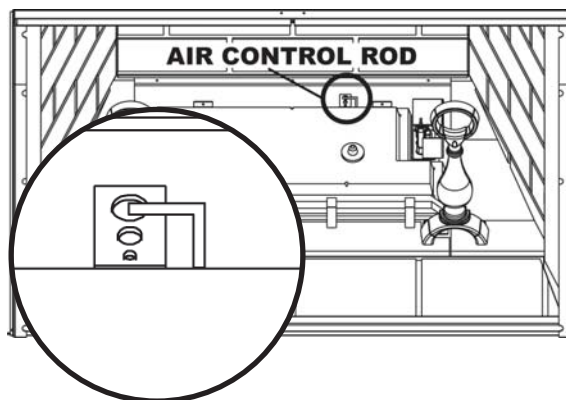

11.0 MAINTENANCE

WARNING

TURN OFF THE GAS AND ELECTRICAL POWER BEFORE SERVICING THE APPLIANCE.

APPLIANCE MAY BE HOT, DO NOT SERVICE UNTIL APPLIANCE HAS COOLED.

DO NOT USE ABRASIVE CLEANERS.

CAUTION: Label all wires prior to disconnection when servicing controls. Wiring errors can cause improper and dangerous operation. Verify proper operation after servicing. This appliance and its venting system should be inspected before use and at least annually by a qualified service person. The appliance area must be kept clear and free of combustible materials, gasoline or other flammable vapors and liquids. The flow of combustion and ventilation air must not be obstructed.

1. In order to properly clean the burner and pilot assembly, remove the logs, rocks and/or glass to expose both assemblies.
2. Keep the control compartment, media, burner, air shutter opening and the area surrounding the logs clean by vacuuming or brushing, at least once a year.
3. Check to see that all burner ports are burning. Clean out any of the ports which may not be burning or are not burning properly.
4. Check to see that the pilot flame is large enough to engulf the flame sensor and/or thermocouple / thermopile as well as reaches the burner.
5. Replace the cleaned logs, rocks or glass. Failure to properly position the media may cause carboning which can be distributed in the surrounding living area.
6. Check to see that the main burner ignites completely on all openings when turned on. A 5 to 10 second total light-up period is satisfactory. If ignition takes longer, consult your local authorized dealer / distributor.
7. Check that the gasketing on the sides, top and bottom of the door is not broken or missing. Replace if necessary.
8. If for any reason the vent air intake system is disassembled, re-install and re-seal per the instructions provided for the initial installation.

40.1

11.1 INNER ACCESS PANEL

The control area can be accessed either through the control door or through the inner access panel inside the firebox.

Follow the door removal instructions, see “DOOR REMOVAL / INSTALLATION” section. Remove the right side brick panel. Remove the four screws from the inner access panel, see “BLOWER REPLACEMENT” section for details.

NOTE: A new gasket will be required, when re-installing the access panel, see “REPLACEMENTS” section.

11.2 NIGHT LIGHT™ REPLACEMENT

Your appliance comes equipped with our “Night Light™”. The light has been pre-wired and is controlled from the remote control.

If in the event the lamp or lens needs to be replaced, follow the instructions below.

11.2.1 Unplug the remote receiver from the junction box located behind the inner access panel.

11.2.2 Remove the four screws that secure the lens frame. This frame retains the glass lens. The lamp can now be accessed.

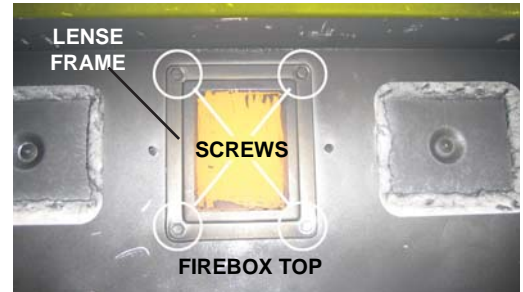

NOTE: Do not handle the lamp (bulb) with bare fingers, protect with a clean dry cloth.

The lamp will pull straight out of the socket. Replace with Wolf Steel parts only, as lamp and lens are special “high temperature” products. When re-installing, ensure integrity of gasket seal.

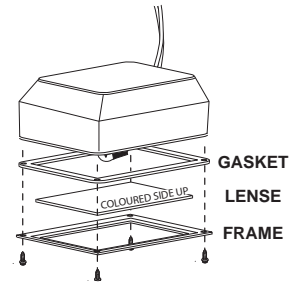

THE FIREBOX MUST BE SEALED.

Over tightening the screws could break the lens. “Light Leakage” from the upper area may be observed. The holes in the lamp housing are necessary for ventilation and must not be covered.

11.3 BLOWER REPLACEMENT

Your appliance comes equipped with a heat circulating blower. The blower is pre-wired and is controlled by the remote control supplied with the unit. For control details, see “OPERATION” section.

Drywall dust will penetrate into the blower bearings, causing irreparable damage. Care must be taken to prevent drywall dust from coming into contact with the blower or its compartment. Any damage resulting from this condition is not covered by the warranty policy.

11.3.1 Turn off the power to the appliance.

11.3.2 Turn off the gas valve.

11.3.3 Remove the glass door, logs, rear log support, side brick panels, rear baffle, and rear panel.

11.3.4 The mounting plate can now be removed. Remove the six screws that secure the plate to the firebox back. The blower is secured to this plate.

11.3.5 Disconnect the wire connectors and ground before attempting to remove the blower from the plate.

11.3.6 When re-installing the replacement blower, it will be necessary to replace the gasket (W290-0091) on the mounting plate.

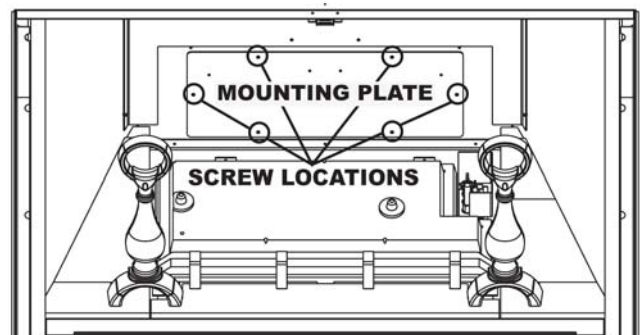
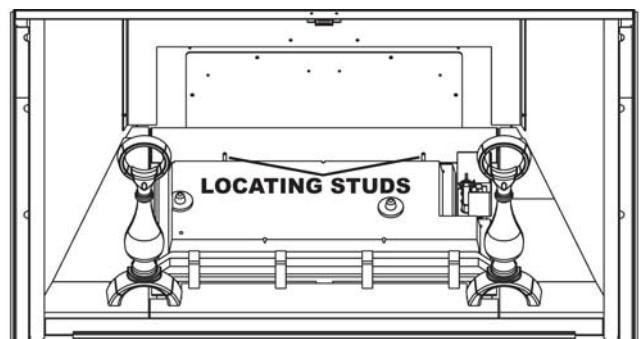
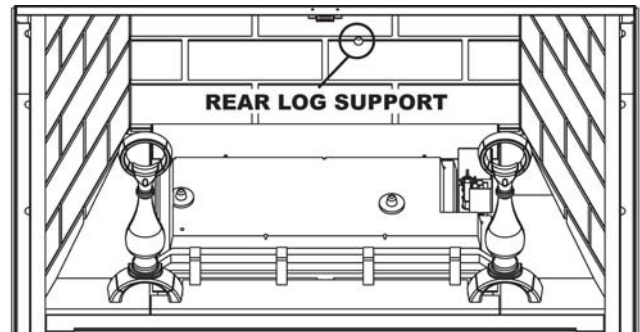

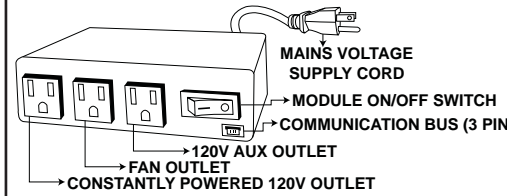
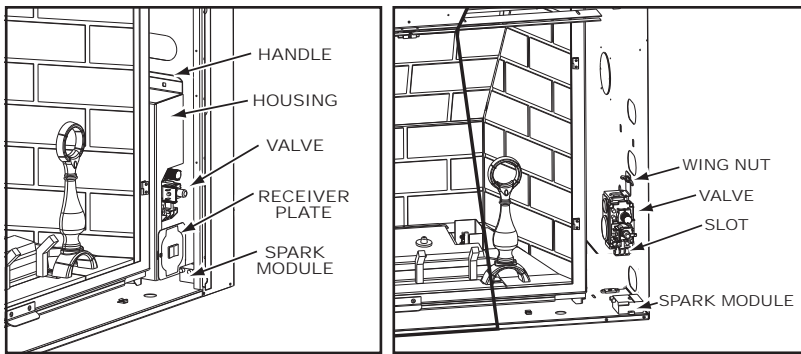

11.4 REMOTE RECEIVER REMOVAL

- 11.4.1 Open the right control door by pulling bottom portion away from magnet catch.
- 11.4.2 Remove the hearth strip by lifting up and away from unit.
- 11.4.3 Remove the receiver by pulling the left side of the plate away from the bracket.
- 11.4.4 Once disengaged pull the wiring harness out from the back of receiver.

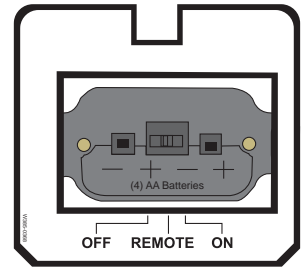

11.5 VALVE REMOVAL

The valve on your appliance is piped with two flex connectors (one inlet, one outlet). It can be removed or pulled forward for service.

- 11.5.1 Remove the hearth strip.
- 11.5.2 Open the right control door.
- 11.5.3 Remove the switch plate by pulling on the left side.
- 11.5.4 Remove the valve housing by pulling on the handle.
- 11.5.5 Lift up and set the housing towards the back of the appliance.
- 11.5.6 Remove the wing nut and pivot the valve out from the slot at the bottom of the valve.
- 11.5.7 Slowly pull the valve through the control door careful not to kink the gas lines or wires.
- 11.5.8 Replace all components before returning the appliance to service.

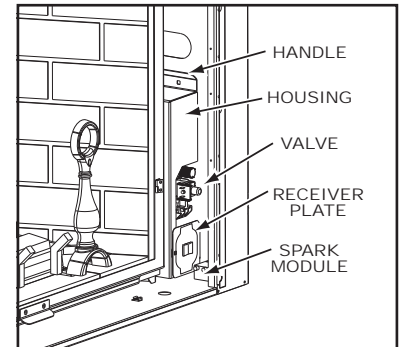

11.6 "AUTO SPARK" BATTERY REMOVAL

This unit is equipped with a spark module that will provide the spark to pilot when the pilot knob is pushed in. It will be necessary to install the "AAA" battery supplied. Install and replace batteries as noted below:

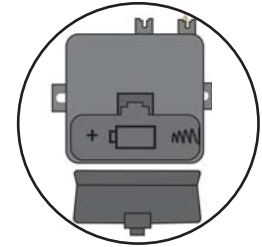
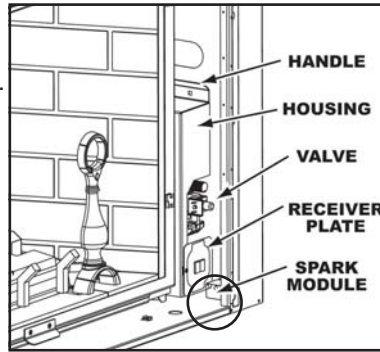

- 11.6.1 Open the right control door by pulling bottom portion away from magnet catch.
- 11.6.2 Remove the hearth strip by lifting up and away from unit.
- 11.6.3 The spark module is located in the front right corner of the unit (see photo below).
- 11.6.4 Disengage the battery compartment door from the top of module.
- 11.6.5 Replace battery and re-install compartment door.

11.7 CARE OF GLASS

DO NOT CLEAN GLASS WHEN HOT! DO NOT USE ABRASIVE CLEANERS TO CLEAN GLASS.

Buff lightly with a clean dry soft cloth. Clean both sides of the glass after the first 10 hours of operation with a recommended fireplace glass cleaner. Thereafter clean as required. If the glass is not kept clean permanent discoloration and / or blemishes may result.



5.1

11.8 RESTRICTING VERTICAL VENTS

Vertical terminations may display a very active flame. If this appearance is not desirable, the vent exit may be restricted using restrictor supplied. This reduces the velocity of the exhaust gases, slowing down the flame pattern and creating a more traditional appearance.

- A. Remove all obstructing obstacles i.e.: Brick panels, logs, etc.
- B. Remove the two screws from the firebox top.
- C. Line up the holes on the restrictor plate with the holes in the top of the firebox and replace the screws.
- D. Replace the brick panels, logs, etc.

77.1

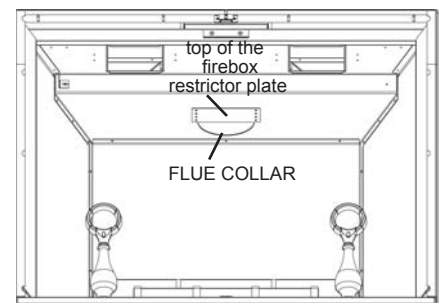

12.0 REPLACEMENTS

Contact your dealer or the factory for questions concerning prices and policies on replacement parts. Normally all parts can be ordered through your Authorized dealer / distributor.

FOR WARRANTY REPLACEMENT PARTS, A PHOTOCOPY OF THE ORIGINAL INVOICE WILL BE REQUIRED TO HONOUR THE CLAIM.

When ordering replacement parts always give the following information:

- Model & Serial Number of appliance
- Installation date of appliance
- Part number
- Description of part
- Finish

*** IDENTIFIES ITEMS WHICH ARE NOT ILLUSTRATED. FOR FURTHER INFORMATION, CONTACT YOUR AUTHORIZED DEALER.**

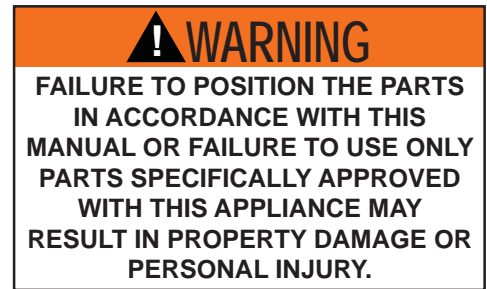

41.1

COMPONENTS		
REF NO.	GD80	DESCRIPTION
1	W135-0205	#1 - REAR LOG
2	W135-0206	#2 - MIDDLE LOG - NG
3	W135-0207	#3 - RIGHT LOG
4	W135-0208	#4 - LEFT LOG
5	W135-0218	#5 - CROSSOVER LOG
6	GL-644	LOG SET ASSEMBLY - NG
7	GL-647	LOG SET ASSEMBLY - LP
8	W135-0221	#2 - MIDDLE LOG - LP
9*	W390-0002	DOOR LATCH (EA)
10	W725-0047	NATURAL GAS VALVE - MODULATING
10	W725-0048	PROPANE GAS VALVE - MODULATING
11	W455-0024	#30 NATURAL GAS ORIFICE
11	W455-0042	#49 PROPANE GAS ORIFICE
12	W680-0014	THERMOCOUPLE**
13	W240-0006	ELECTRODE C/W LEAD
14	W680-0015	THERMOPILE
15	W010-1194	NATURAL GAS PILOT ASSEMBLY
15	W010-1201	PROPANE GAS PILOT ASSEMBLY
16	W455-0070	NG PILOT INJECTOR
16	W455-0068	LP PILOT INJECTOR
17*	W385-0334	NAPOLEON® LOGO
18*	W562-0037	DOOR GASKET (132")
19	W010-1800	FIRESTOP
20	W010-1202	BURNER
21	W062-0010	BLOWER
22	W660-0041	SPARK SWITCH
23*	W660-0071	REMOTE TRANSMITTER
24*	W660-0075	SWITCH, PROFLAME S-RECEIVER
25	W190-0017	DC SPARK UNIT CONTROL
26*	W715-0629	CAST IRON TRIM
27	W185-0020	CAST GRATE
28	W010-1342	DOOR WELD ASSEMBLY
29*	W010-1289	GLASS C/W GASKET
30	W565-0078	SCREEN
31*	W290-0091	BLOWER MOUNTING GASKET
32*	W120-0054	CURTAIN ROD CAP
33	W500-0206	TERMINAL EXTENSION PLATE
34*	W290-0099	ACCESS DOOR GASKET

35	W300-0086	NIGHT LIGHT™ GLASS
36	W387-0006	NIGHT LIGHT™ LAMP
37	W750-0178	NIGHT LIGHT™ WIRE HARNESS
38	W290-0080	NIGHT LIGHT™ LENSE GASKET
39	W660-0086	SWITCH, FAN CONTROL
FLEXIBLE VENT KITS		
REF NO.	GD80	DESCRIPTION
GD420 (5 FT)		
40*	W010-0772	5" FLEX VENT PIPE - (5 FT) C/W SPACERS
40*	W730-0012	8" FLEX VENT PIPE - (5 FT)
GD430 (10 FT)		
40*	W730-0013	8" FLEX VENT PIPE - (10 FT)
40*	W010-0773	5" FLEX VENT PIPE - (10 FT) C/W SPACERS
TERMINAL KITS		
REF NO.	GD80	DESCRIPTION
41*	W010-0067	ASSEMBLY, SUPPORT RING
42	GD401	PERISCOPE
ROOF TERMINAL KITS		
REF NO.	GD80	DESCRIPTION
43	GD422R-1	WALL TERMINAL KIT
44*	GD410	1/12 TO 7/12 PITCH
45*	GD411	8/12 TO 12/12 PITCH
46*	GD412	FLAT ROOF
47	W670-0007	5/8 AIR TERMINAL
48	W490-0074	5/8 INNER/OUTER SLEEVE
49	W170-0086	STORM COLLAR
50	W010-0453	ROOF SUPPORT
51	W263-0065 /	ROOF FLASHING, FLAT
	W263-0066 /	1/12 TO 7/12
	W263-0055	8/12 TO 12/12
ACCESSORIES		
REF NO.	GD80	DESCRIPTION
52*	W573-0007	HI-TEMP SEALANT
53*	GD501	HEAT GUARD
54	GA-566	HOT AIR DISTRIBUTION KIT
55	GA-72	HOT AIR EXHAUST KIT
56	GA-70	EXTENSION KIT, 5FT FLEX VENT
57*	W010-0370	WALL SUPPORT ASSEMBLY
58*	W175-0166	5" COUPLER
59*	W175-0002	8" COUPLER
60*	W175-0260	CONVERSION KIT - NG TO LP
61*	W175-0261	CONVERSION KIT - LP TO NG
62	FK80-R	FRAMING KIT - RECTANGULAR
63	FK80-A	FRAMING KIT - ARCHED
64*	DK80A-HC	DECORATIVE DOORS-HAMMERED COPPER-ARCHED
65*	DK80R-HC	DECORATIVE DOORS-HAMMERED COPPER-RECTANGULAR
64*	DK80A-HP	DECORATIVE DOORS-HAMMERED PEWTER-ARCHED
65*	DK80R-HP	DECORATIVE DOORS-HAMMERED PEWTER-RECTANGULAR
66	GD800-KT	OLD TOWN RED BRICK KIT
66	GD806-KT	HERRINGBONE/SANDSTONE BRICK KIT
66	GD807-KT	SANDSTONE BRICK KIT
67	PRP80	PORCELAIN REFLECTIVE PANELS BRICK KIT

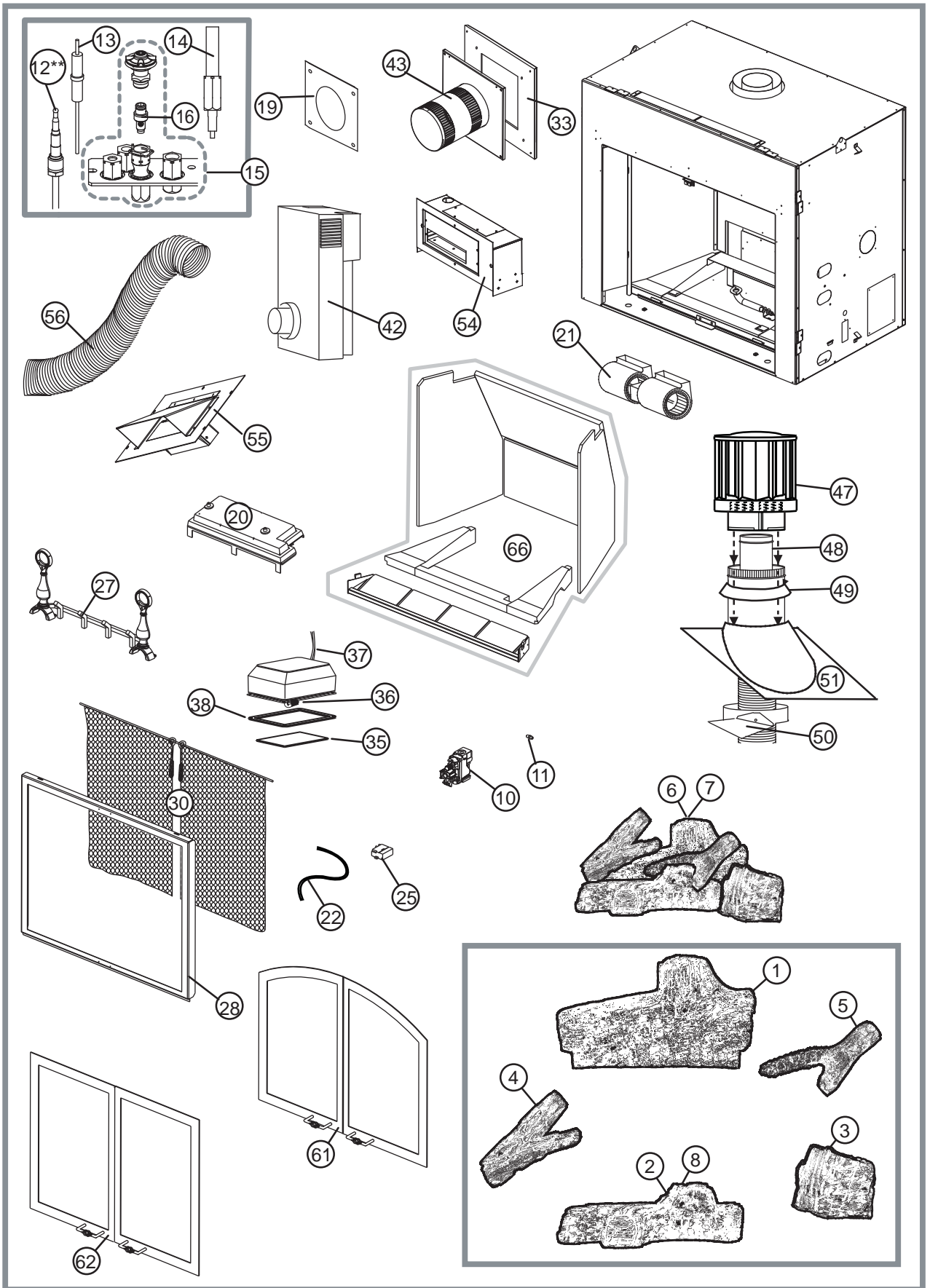

13.0 TROUBLE SHOOTING

! WARNING

ALWAYS LIGHT THE PILOT WHETHER FOR THE FIRST TIME OR IF THE GAS SUPPLY HAS RAN OUT, WITH THE GLASS DOOR OPEN OR REMOVED.

TURN OFF THE GAS AND ELECTRICAL POWER BEFORE SERVICING THE APPLIANCE.

APPLIANCE MAY BE HOT, DO NOT SERVICE UNTIL APPLIANCE HAS COOLED.

DO NOT USE ABRASIVE CLEANERS.

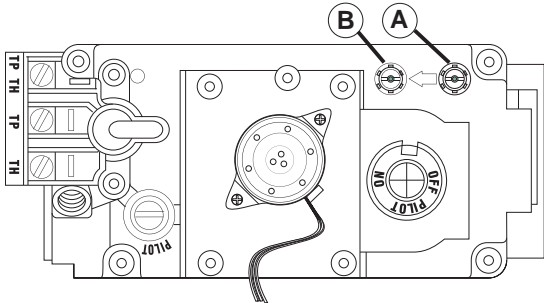
SYMPTOM	PROBLEM	TEST SOLUTION
Main burner flame is a blue, lazy, transparent flame.	Blockage in vent.	<ul style="list-style-type: none"> - Remove blockage. In really cold conditions, ice buildup may occur on the terminal and should be removed as required.
	Incorrect installation.	<ul style="list-style-type: none"> - Refer to "VENTING" section to ensure correct location of storm collars.
Flames are consistently too large or too small. Carboning occurs.	Unit is over-fired or underfired.	<ul style="list-style-type: none"> - Check pressure readings: <i>Inlet pressure</i> can be checked by turning screw (A) counter-clockwise 2 or 3 turns and then placing pressure gauge tubing over the test point. Gauge should read 7" (minimum 4.5") water column for natural gas or 13" (minimum 11") water column for propane. Check that main burner is operating on 'HI'. <i>Outlet pressure</i> can be checked the same as above using screw (B). Gauge should read 3.5" water column for natural gas or 10" water column for propane. Check that main burner is operating on 'HI'. AFTER TAKING PRESSURE READINGS, BE SURE TO TURN SCREWS CLOCKWISE FIRMLY TO RESEAL. DO NOT OVER TORQUE. Leak test with a soap and water solution.
		
Carbon is being deposited on glass, logs or combustion chamber surfaces.	Air shutter has become blocked.	<ul style="list-style-type: none"> - Ensure air shutter opening is free of lint or other obstructions.
	Flame is impinging on the logs or combustion chamber.	<ul style="list-style-type: none"> - Check that the logs are correctly positioned. - Open air shutter to increase the primary air. - Check the input rate: check the manifold pressure and orifice size as specified by the rating plate values. - Check that the door gasketing is not broken or missing and that the seal is tight. - Check that both vent liners are free of holes and well sealed at all joints. - Check that minimum rise per foot has been adhered to for any horizontal venting.
White / grey film forms.	Sulphur from fuel is being deposited on glass, logs or combustion chamber surfaces.	<ul style="list-style-type: none"> - Clean the glass with a recommended gas fireplace glass cleaner. DO NOT CLEAN GLASS WHEN HOT. - If deposits are not cleaned off regularly, the glass may become permanently marked.
Exhaust fumes smelled in room, headaches.	Fireplace is spilling.	<ul style="list-style-type: none"> - Ensure exhaust bracket gasket seal. - Check door seal. - Check for exhaust blockage. - Check that venting is installed correctly. - Room is in negative pressure; increase fresh air supply.

SYMPTOM	PROBLEM	TEST SOLUTION	
Main burner goes out; pilot stays on.	Pilot flame is not large enough or not engulfing the thermopile.	<ul style="list-style-type: none"> - Turn up the pilot flame. - Replace pilot assembly. 	
	Thermopile shorting.	<ul style="list-style-type: none"> - Clean thermopile connection to the valve. Reconnect. - Replace thermopile / valve. 	
	Remote wall switch wire is too long; too much resistance in the system.	<ul style="list-style-type: none"> - Shorten wire to connect length or wire gauge. 	
	Faulty thermostat or switch.	<ul style="list-style-type: none"> - Replace. 	
Main burner goes out; pilot goes out.	Refer to "MAIN BURNER GOES OUT; PILOT STAYS ON"		
	Vent is blocked	<ul style="list-style-type: none"> - Check for vent blockage. 	
	Vent is re-circulating	<ul style="list-style-type: none"> - Check joint seals and installation 	
	Flexible vent has become disconnected from fireplace.	<ul style="list-style-type: none"> - Re-attach to fireplace. - Cap was not replaced. 	
Pilot goes out when the gas knob is released. The gas valve has an interlock device which will not allow the pilot burner to be lit until the thermocouple has cooled. Allow approximately 60 seconds for the thermocouple to cool.	System is not correctly purged.	<ul style="list-style-type: none"> - Purge the gas line. 	
	Out of propane gas.	<ul style="list-style-type: none"> - Fill the tank. 	
	Pilot flame is not large enough.	<ul style="list-style-type: none"> - Turn up the pilot flame. 	
	Pilot flame is not engulfing the thermocouple	<ul style="list-style-type: none"> - Gently twist the pilot head to improve the flame pattern around the thermocouple. 	
	Thermocouple shorting / faulty.	<ul style="list-style-type: none"> - Loosen and tighten thermocouple. - Clean thermocouple and valve connection. - Replace thermocouple. - Replace valve. 	
	Faulty valve.	<ul style="list-style-type: none"> - Replace. 	
Pilot burning; no gas to main burner; gas knob is on 'HI'; wall switch / thermostat is on.	Thermostat or switch is defective	<ul style="list-style-type: none"> - Connect a jumper wire across the wall switch terminals; if main burner lights, replace switch / thermostat. 	
	Wall switch wiring is defective.	<ul style="list-style-type: none"> - Disconnect the switch wires & connect a jumper wire across terminals 1 & 3; if the main burner lights, check the wires for defects and / or replace wires. 	
	Main burner orifice is plugged.	<ul style="list-style-type: none"> - Remove stoppage in orifice. 	
	Faulty valve.	<ul style="list-style-type: none"> - Replace. 	
Pilot will not light.	No spark at pilot burner.	<ul style="list-style-type: none"> - Check if pilot can be lit by a match. - Check that the wire is connected to the push button igniter. - Check if the push button igniter needs tightening. - Replace the wire if the wire insulation is broken or frayed. - Replace the electrode if the ceramic insulator is cracked or broken. - Replace the push button ignitor 	
		Out of propane gas.	<ul style="list-style-type: none"> - Fill the tank.
		Spark gap is incorrect.	<ul style="list-style-type: none"> - Spark gap should be 0.150" to 0.175" (5/32" to 11/64" approx.) from the electrode tip and the pilot burner. To ensure proper electrode location, tighten securing nut (finger tight plus 1/4 turn).
		No gas at the pilot burner.	<ul style="list-style-type: none"> - Check that the manual valve is turned on. - Check the pilot orifice for blockage. - Replace the valve. - Call the gas distributor.

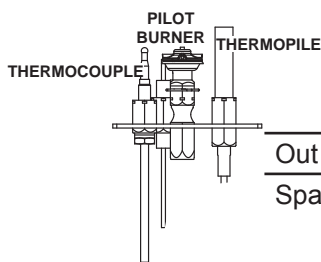

SYMPTOM	PROBLEM	TEST SOLUTION
Pilot goes out while standing: Main burner is in "OFF" position.	Gas piping is undersized.	<ul style="list-style-type: none"> - Turn on all gas appliances and see if pilot flame flutters, diminishes or extinguishes, especially when main burner ignites. Monitor appliance supply working pressure. - Check if supply piping size is to code. Correct all undersized piping.
Remote wall switch is in "OFF" position; main burner comes on when gas knob is turned to "ON" position.	Wall switch is mounted upside down.	<ul style="list-style-type: none"> - Reverse.
	Remote wall switch is grounding.	<ul style="list-style-type: none"> - Replace.
	Remote wall switch wire is grounding.	<ul style="list-style-type: none"> - Check for ground (short); repair ground or replace wire.
	Faulty valve.	<ul style="list-style-type: none"> - Replace.

42.2_3

14.0 WARRANTY

NAPOLEON® products are manufactured under the strict Standard of the world recognized ISO 9001 : 2008 Quality Assurance Certificate.

NAPOLEON® products are designed with superior components and materials assembled by trained craftsmen who take great pride in their work. The burner and valve assembly are leak and test-fired at a quality test station. The complete heater is again thoroughly inspected by a qualified technician before packaging to ensure that you, the customer, receives the quality product that you expect from NAPOLEON®.

NAPOLEON® GAS FIREPLACE PRESIDENT'S LIFETIME LIMITED WARRANTY

The following materials and workmanship in your new NAPOLEON® gas heater are warranted against defects for as long as you own the heater. This covers: combustion chamber, heat exchanger, stainless steel burner, phazer™ logs and embers, rocks, ceramic glass (thermal breakage only), gold plated parts against tarnishing, porcelainized enameled components and aluminum extrusion trims.*
Electrical (110V and millivolt) components and wearable parts such as blowers, gas valves, thermal switch, switches, wiring, remote controls, ignitor, gasketing, and pilot assembly are covered and NAPOLEON® will provide replacement parts free of charge during the first year of the limited warranty.*
Labour related to warranty repair is covered free of charge during the first year. Repair work, however, requires the prior approval of an authorized company official. Labour costs to the account of NAPOLEON® are based on a predetermined rate schedule and any repair work must be done through an authorized NAPOLEON® dealer.
* Construction of models vary. Warranty applies only to components included with your specific heater.

CONDITIONS AND LIMITATIONS

NAPOLEON® warrants its products against manufacturing defects to the original purchaser only. Registering your warranty is not necessary. Simply provide your proof of purchase along with the model and serial number to make a warranty claim. NAPOLEON® reserves the right to have its representative inspect any product or part thereof prior to honouring any warranty claim. Provided that the purchase was made through an authorized NAPOLEON® dealer your heater is subject to the following conditions and limitations:
This factory warranty is non-transferable and may not be extended whatsoever by any of our representatives.
The gas heater must be installed by a licensed, authorized service technician or contractor. Installation must be done in accordance with the installation instructions included with the product and all local and national building and fire codes. This limited warranty does not cover damages caused by misuse, lack of maintenance, accident, alterations, abuse or neglect and parts installed from other manufacturers will nullify this warranty.
This limited warranty further does not cover any scratches, dents, corrosion or discoloring caused by excessive heat, abrasive and chemical cleaners nor chipping on porcelain enamel parts, mechanical breakage of PHAZER™ logs and embers.
NAPOLEON® warrants its stainless steel burners against defects in workmanship and material for life, subject to the following conditions: During the first 10 years NAPOLEON® will replace or repair the defective parts at our option free of charge. From 10 years to life, NAPOLEON® will provide replacement burners at 50% of the current retail price.
In the first year only, this warranty extends to the repair or replacement of warranted parts which are defective in material or workmanship provided that the product has been operated in accordance with the operation instructions and under normal conditions.
After the first year, with respect to this President's Lifetime Limited Warranty, NAPOLEON® may, at its discretion, fully discharge all obligations with respect to this warranty by refunding to the original warranted purchaser the wholesale price of any warranted but defective part(s).
NAPOLEON® will not be responsible for installation, labour or any other expenses related to the reinstallation of a warranted part and such expenses are not covered by this warranty.
Notwithstanding any provisions contained in the President's Lifetime Limited Warranty, NAPOLEON'S responsibility under this warranty is defined as above and it shall not in any event extend to any incidental, consequential or indirect damages.
This warranty defines the obligations and liability of NAPOLEON® with respect to the NAPOLEON® gas heater and any other warranties expressed or implied with respect to this product, its components or accessories are excluded.
NAPOLEON® neither assumes, nor authorizes any third party to assume, on its behalf, any other liabilities with respect to the sale of this product.
NAPOLEON® will not be responsible for: over-firing, downdrafts, spillage caused by environmental conditions such as rooftops, buildings, nearby trees, hills, mountains, inadequate vents or ventilation, excessive venting configurations, insufficient makeup air, or negative air pressures which may or may not be caused by mechanical systems such as exhaust fans, furnaces, clothes dryers, etc. Any damages to heater, combustion chamber, heat exchanger, brass trim or other components due to water, weather damage, long periods of dampness, condensation, damaging chemicals or cleaners will not be the responsibility of NAPOLEON®.

ALL SPECIFICATIONS AND DESIGNS ARE SUBJECT TO CHANGE WITHOUT PRIOR NOTICE DUE TO ON-GOING PRODUCT IMPROVEMENTS. NAPOLEON® IS A REGISTERED TRADEMARK OF WOLF STEEL LTD. PATENTS U.S. 5.303.693.801 - CAN. 2.073.411, 2.082.915. © WOLF STEEL LTD.

