

25" x 22" x 11.5"

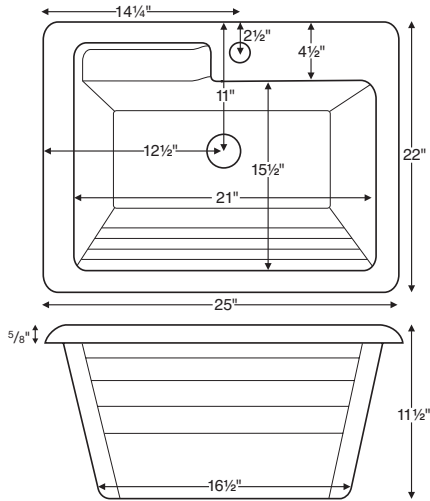

Universal
Part # - MTL-110



AVAILABLE COLORS

- White - Part # MTL110W \$390
- Bone, Biscuit - Part # MTL110B* \$405
- Black, Sterling Silver - Part # MTL110GRP1* \$455
- *Must specify color on order*

OPTIONS

- Quick Ship/Priority. *Call for availability.* Part # QUISINKSH \$175
- Shipping Weight: 15 lbs

NOTES: Measurements are $\pm 1/2"$ and are subject to change without notice. Data herein supersedes all previous prior to publication date indicated below.

25" x 22" x 12.5"

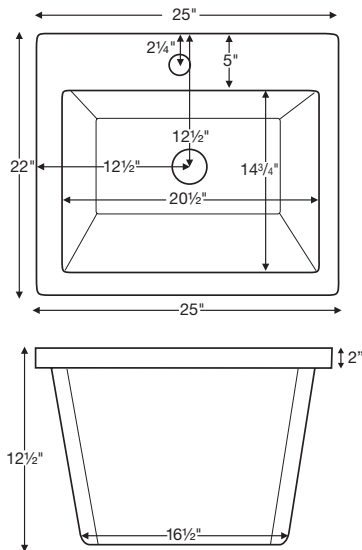

Versatile
Part # - MTL-120



AVAILABLE COLORS

- White - Part # MTL120W \$405
- Bone, Biscuit - Part # MTL120B* \$415
- Black, Sterling Silver - Part # MTL120GRP1* \$485
- *Must specify color on order*

OPTIONS

- Quick Ship/Priority. *Call for availability.* Part # QUISINKSH \$175
- Shipping Weight: 17 lbs

NOTES: Measurements are $\pm 1/2"$ and are subject to change without notice. Data herein supersedes all previous prior to publication date indicated below.

CONSTRUCTION AND STANDARD FEATURES

- Single-bowl design; 3.5" drain opening pre-drilled.
- **Can be undermounted or caulked directly to the countertop without the use of clips or channels. SPECIFY WHEN ORDERING.**
- No holes drilled standard; up to 3 holes drilled by MTI at no additional charge.
- Durable Lucite® cast acrylic shell is extremely scratch- and stain-resistant yet renewable because the color goes all the way through the material.
- Non-porous surface makes cleaning and sanitizing faster and more effective.
- Multi-layered reinforced backing of thick fiberglass / resin / titanium.
- At least 30% thicker and stronger than other makes.
- 2-year limited residential; 1-year commercial warranty.