



Buy it for looks. Buy it for life.®

Please contact Moen first

For Installation Help, Missing or Replacement Parts

(USA)

1-800-BUY-MOEN (1-800-289-6636)

Mon - Fri 8:00 AM to 8:00 PM, Eastern

Sat. 9:00 AM to 5:30 PM Eastern

WWW.MOEN.COM/MOTIONSENSE/SUPPORT

(Canada)

1-800-465-6130

Mon - Fri 7:30 AM to 8:00 PM, Eastern

WWW.MOEN.CA

Por favor, contáctese primero con Moen

Para obtener ayuda de instalación, piezas faltantes o de recambio

01-800-718-4345

Lunes a viernes de 8:00 a 20:00 hs.

(Costa Este)

Sáb. 8:00 a 18:30 hs. (Costa Este)

WWW.MOEN.MX

Veillez appeler Moen d'abord

Pour l'aide d'installation, les Disparus ou les Pièces de Rechange

1-800-465-6130

Du lundi au vendredi:

7h 30 à 20h, HE

WWW.MOEN.CA

Don't forget to register and review your product by scanning the code below or visiting moen.com/motionsense/support

Download reader at getscanlife.com

No olvide registrar y revisar su producto escaneando el código incluido a continuación o visitando moen.com/motionsense/support

Descargue el programa de lectura en getscanlife.com

Ne pas oublier d'enregistrer et de passer en revue votre produit en scannant le code ci-dessous ou en visitant le site

moen.com/motionsense/support.

Télécharger le lecteur sur le site getscanlife.com.



Download reader at
getscanlife.com

Installation Guide

Guía de Instalación

Guide d'installation

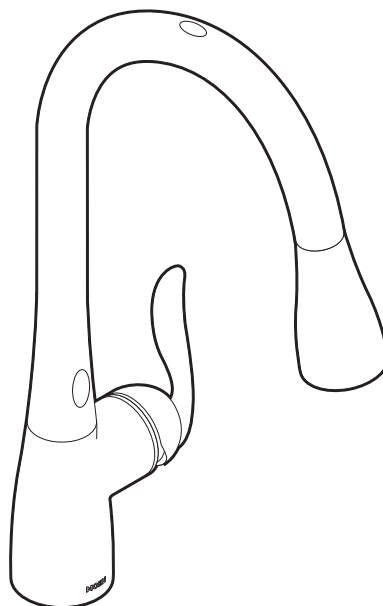

7594E

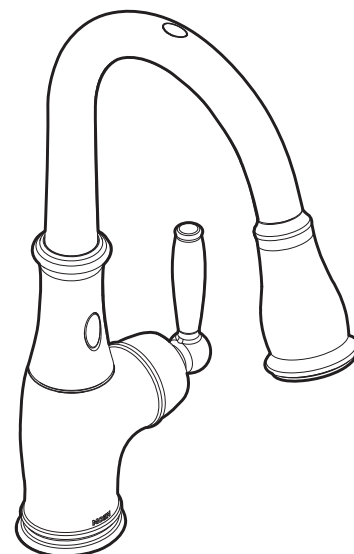

7185E

MOTIONSENSE™
HANDS-FREE KITCHEN FAUCET

COCINA MOTIONSENSE™ HANDS-FREE

MC

AVEC MOTIONSENSE
ROBINET DE CUISINE MAINS LIBRES



INS10188

HELPFUL TOOLS

For safety and ease of faucet replacement, Moen recommends the use of these helpful tools.

HERRAMIENTAS ÚTILES

Para que el cambio de la llave sea fácil y seguro, Moen le recomienda usar estas útiles herramientas.

OUTILS UTILES

Par mesure de sécurité et pour faciliter l'installation, Moen suggère l'utilisation des outils suivants.

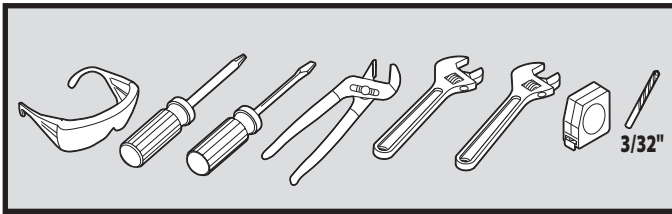

CAUTION — TIPS FOR REMOVAL OF OLD FAUCET:
Always turn water supply OFF before removing existing facet or disassembling the valve. Open faucet handle to relieve water pressure and ensure that complete water shut-off has been accomplished.

PRECAUCIÓN — CONSEJOS PARA CAMBIAR LA LLAVE MEZCLADORA Siempre CIERRE la toma de agua antes de quitar la llave existente o demontar la válvula. Abra la llave para liberar la presión, y asegúrese de que esté bien cerrada el agua.

ATTENTION — SUGGESTIONS POUR ENLEVER L'ANCIEN ROBINET : Toujours couper l'alimentation en eau avant d'enlever ou de démonter le robinet. Ouvrir le robinet pour libérer la pression d'eau et pour s'assurer que l'alimentation en eau a bien été coupée.

Icon Legend/Leyenda de Iconos/ Légende des icônes



Above sink
Encima del lavabo
Dessus de l'évier



Below sink
Debajo del fregadero
Sous l'évier

Parts List

- | | |
|--|--|
| A. Faucet body | M. Hose guide nut |
| B. Spray wand | N. Hose weight |
| C. Deck gasket | O. Control box |
| D. Pulldown hose | P. Zip ties |
| E. Data cable | Q. Battery holder |
| F. Hose weight locator mark | R. Hook & loop fastener |
| G. Deck plate | S. Mounting screws |
| H. Deck plate gasket | T. Installation tool |
| I. Support bracket | U. Pulldown connecting hose |
| J. Mounting washer | V. Batteries* |
| K. Mounting nut | <i>*(For best performance, use non-rechargeable alkaline batteries.)</i> |
| L. Pulldown connecting hose bracket | |

Lista de piezas

- | | |
|--|--|
| A. Cuerpo de la mezcladora | M. Tuerca de guía de la manguera |
| B. Varilla rociadora | N. Peso de la manguera |
| C. Empaque de cubierta | O. Caja de control |
| D. Manguera extensible | P. Abrazaderas plásticas |
| E. Cable de datos | Q. Soporte para batería |
| F. Marca de ubicación del peso de la manguera | R. Sistema de gancho y cierre Hook & loop |
| G. Placa de cubierta | S. Tornillos de montaje |
| H. Empaque de la placa de cubierta | T. Herramienta de instalación |
| I. Ménsula de soporte | U. Manguera extensible |
| J. Arandela de montaje | V. Baterías* |
| K. Tuerca de montaje | <i>*(For best performance, use non-rechargeable alkaline batteries.)</i> |
| L. Ménsula de la manguera extensible | |

Liste des pièces

- | | |
|--|--|
| A. Corps du robinet | M. Écrou de guide-tuyau |
| B. Bec de pulvérisation | N. Poids du tuyau |
| C. Joint d'étanchéité de plate-forme | O. Boîtier de contrôle |
| D. Tuyau de bec rétractable | P. Attaches autobloquantes |
| E. Câble de données | Q. Bloc-piles |
| F. Marque de l'indicateur du poids du tuyau | R. Dispositif de fixation auto-agrippant |
| G. Plaque de pont | S. Vis de montage |
| H. Joint de la plaque de pont | T. Outil d'installation |
| I. Support | U. Tuyau de raccord du bec rétractable |
| J. Rondelle de montage | V. Piles* |
| K. Écrou de montage | <i>*(For best performance, use non-rechargeable alkaline batteries.)</i> |
| L. Support de tuyau de raccord pour bec rétractable | |

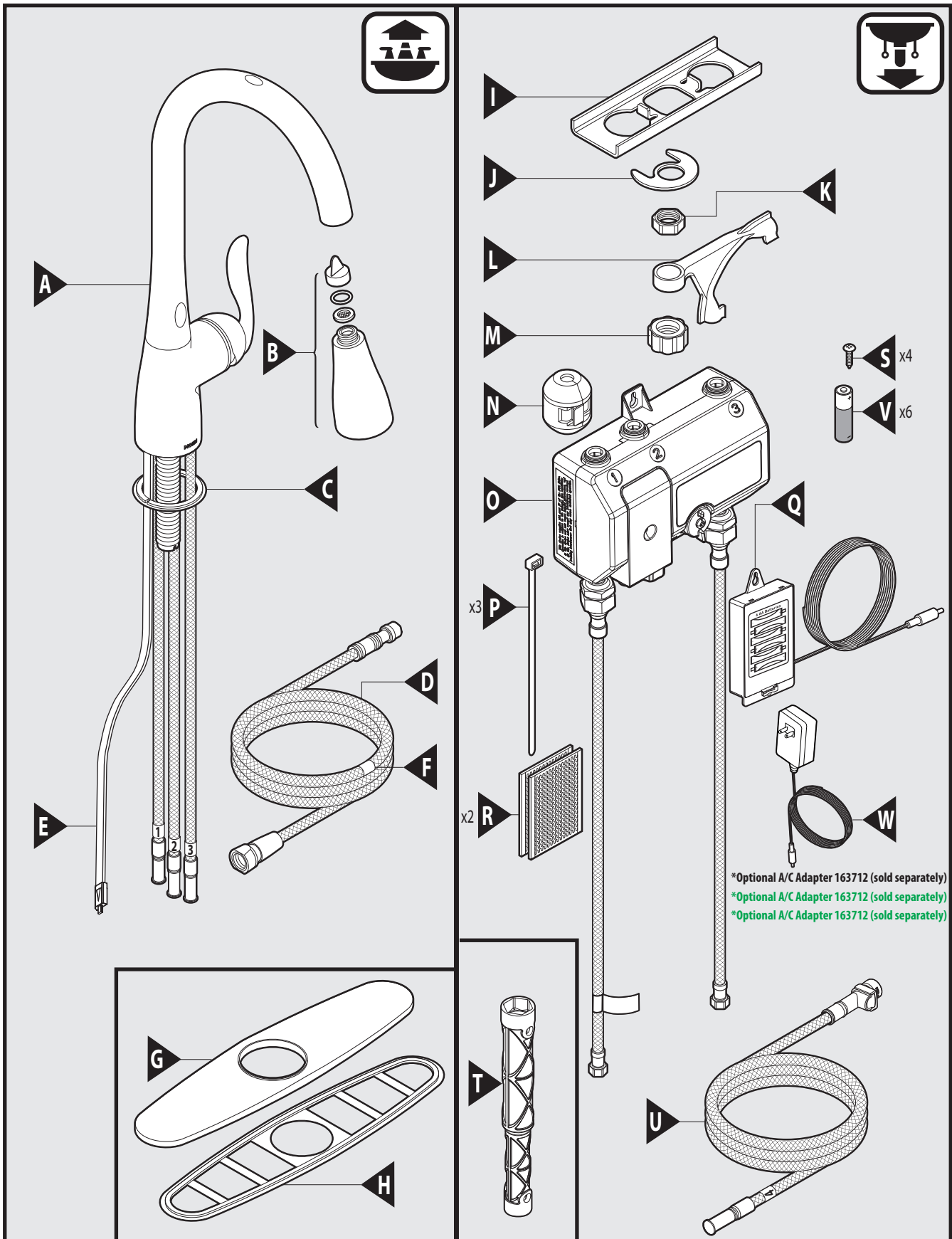

IMPORTANT/IMPORTANT/IMPORTANT

START UP OR RESET PROCEEDURE/START UP OR RESET PROCEEDURE/START UP OR RESET PROCEEDURE

When starting your MotionSense kitchen faucet, observe these three easy steps:

When starting your MotionSense kitchen faucet, observe these three easy steps:

When starting your MotionSense kitchen faucet, observe these three easy steps:

1. Remove the protective labels from the sensors on the top and the front of the spout.

1. Remove the protective labels from the sensors on the top and the front of the spout.

1. Remove the protective labels from the sensors on the top and the front of the spout.

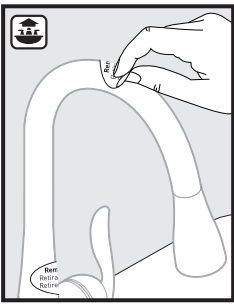

2. Clear people and objects within 3 feet of the faucet sensors.

2. Clear people and objects within 3 feet of the faucet sensors.

2. Clear people and objects within 3 feet of the faucet sensors.

3. Plug in the battery holder cable (or the AC adapter cable) and wait 10 seconds for the faucet to complete the startup process.*

3. Plug in the battery holder cable (or the AC adapter cable) and wait 10 seconds for the faucet to complete the startup process.*

3. Plug in the battery holder cable (or the AC adapter cable) and wait 10 seconds for the faucet to complete the startup process.*

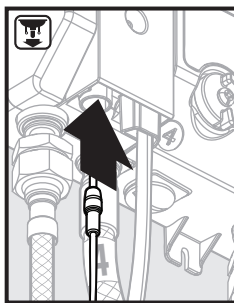

* If faucet is not functioning properly, refer to troubleshooting guide on page 16.

* If faucet is not functioning properly, refer to troubleshooting guide on page 16.

* If faucet is not functioning properly, refer to troubleshooting guide on page 16.

Finished Installation/Instalación terminada/
Installation terminée

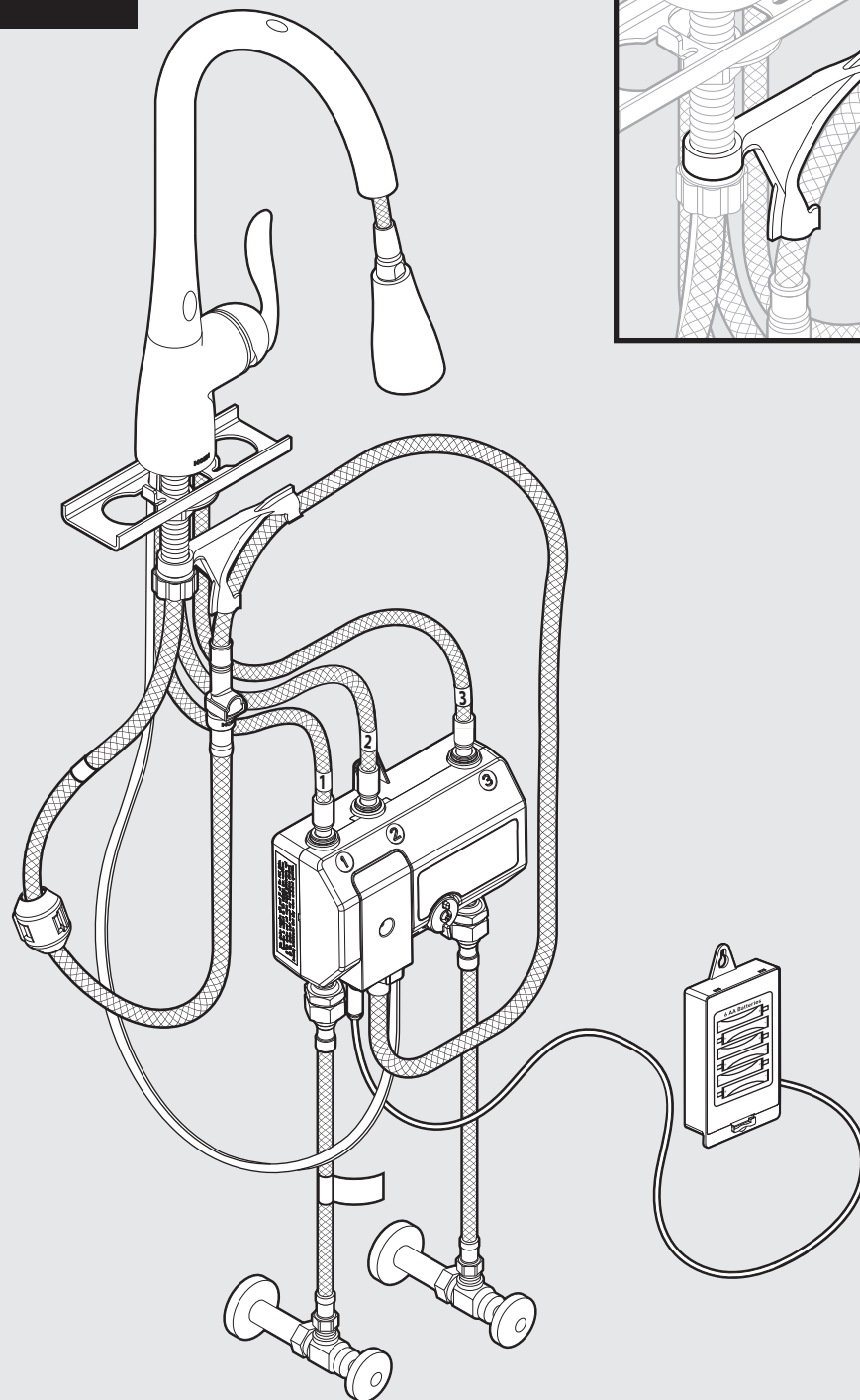

After installing hoses, data cable or power cable can be secured in place using supplied zip ties.

Después de instalar las mangueras, el cable de datos o el cable de alimentación puede asegurarse en su lugar con las abrazaderas plásticas provistas.

Après avoir installé les tuyaux, le câble de données ou le câble électrique peut être fixé en utilisant les attaches autobloquantes fournies.

1a

Single hole/Un orificio/Une ouverture

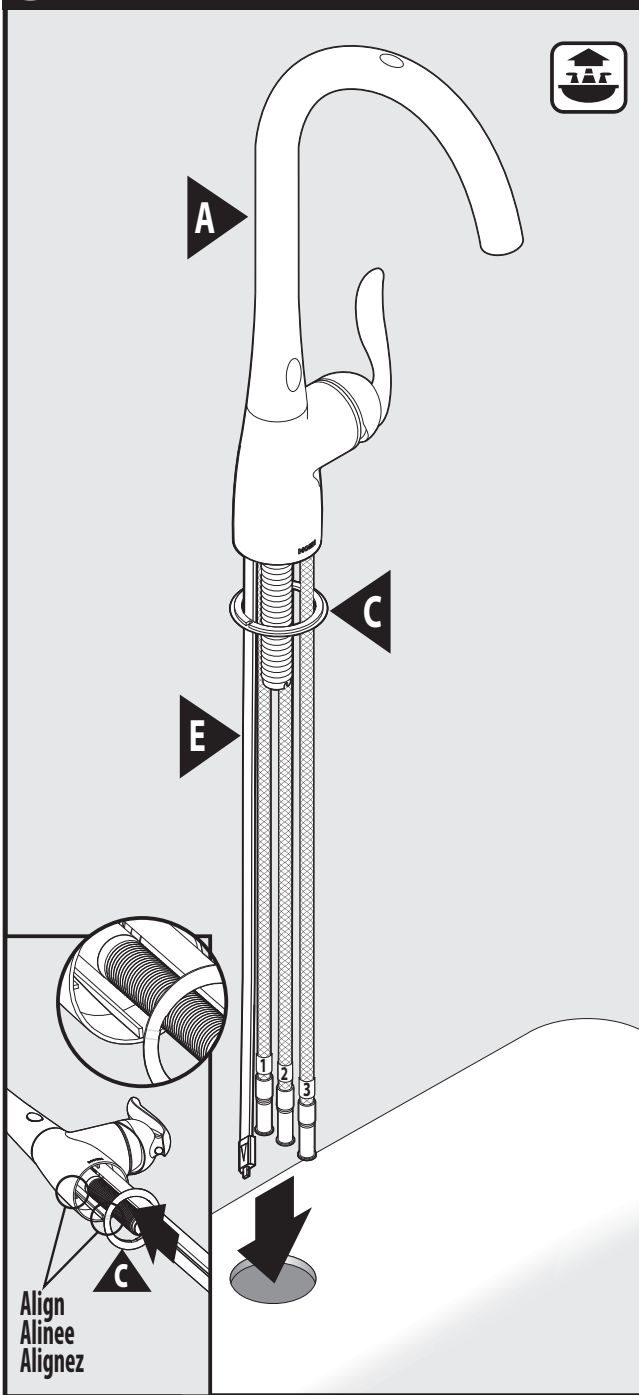

Install faucet body (A)—including hoses, data cable (E), and deck gasket (C)—in hole on sink. **Note:** Installs with handle on right side only.

Instale el cuerpo de la mezcladora (A)—incluyendo las mangueras, el cable de datos (E), y el empaque de cubierta (C)—en el orificio en el fregadero. **Nota:** Se instala con el monomando en el lado derecho solamente.

Installer le corps du robinet (A), y compris les tuyaux, le câble de données (E) et le joint d'étanchéité de plate-forme (C), dans l'ouverture de l'évier. **Remarque :** S'installe uniquement avec la poignée à droite.

1b

Three hole/Tres orificios/Trois ouvertures

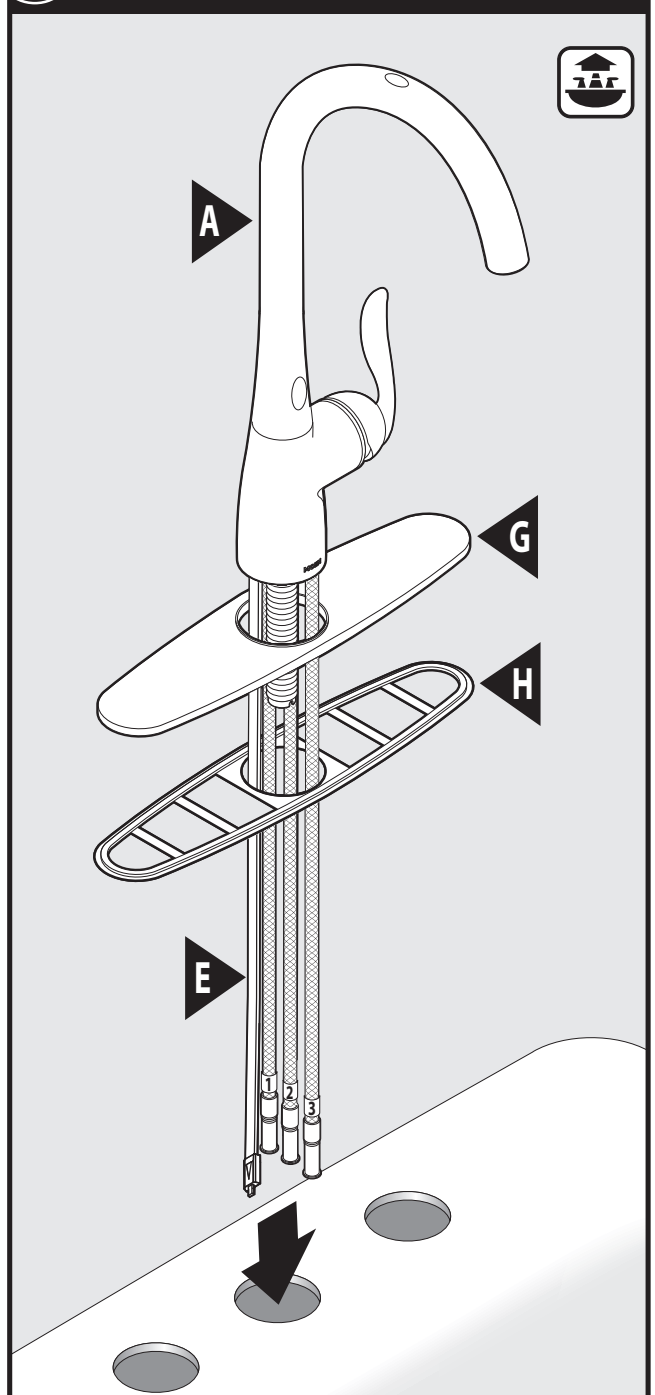

Install faucet body (A)—including hoses, data cable (E), deck plate (G) and deck plate gasket (H)—through center hole on sink. **Note:** Installs with handle on right side only.

Instale el cuerpo del grifo (A)—incluyendo las mangueras, cable de datos (E), placa de cubierta (G) y la cubierta de la placa de la junta (H)—a través del orificio central en el fregadero. **Nota:** Se instala con el mango en el lado derecho solamente.

Installer le corps du robinet (A)—y compris les tuyaux, câble de données (E), plaque de platine (G) et la plaque de pont joint (H)—dans le trou central sur le lavabo. **Remarque:** Installe avec poignée sur le côté droit seulement.

2a Recommended/Recommended/Recommended

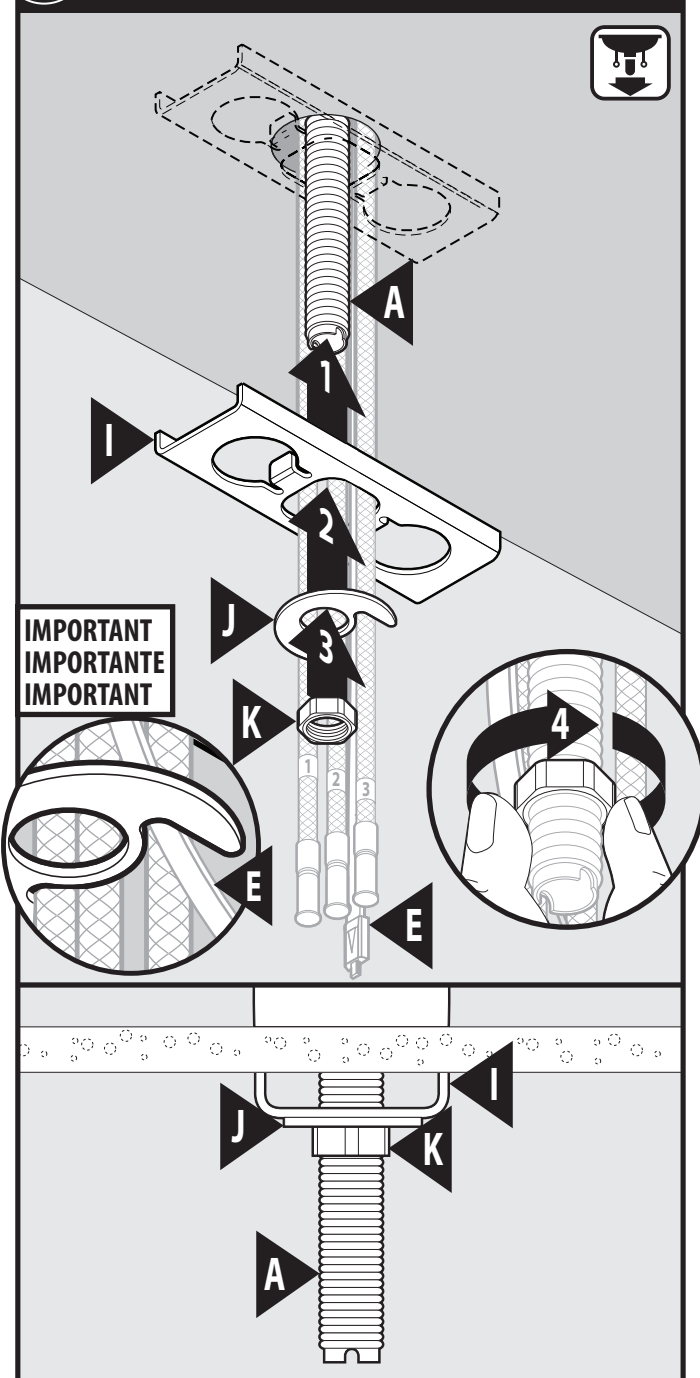

Slide support bracket (I), then mounting washer (J) up onto faucet body (A) under sink and secure with mounting nut (K). **Important: thread data cable through hole in bracket (I) and open side of washer (J). Use care to make sure data cable (E) is not pinched.**

Deslice la ménsula de soporte (I), y luego la arandela de montaje (J) hacia arriba hasta el cuerpo de la mezcladora (A) por debajo del fregadero y asegúrelas con la tuerca de montaje (K). **Importante: haga pasar el cable de datos a través del orificio en la ménsula (I) y el lado abierto de la arandela (J). Use care to make sure data cable (E) is not pinched.**

Sous l'évier, faire glisser le support (I), puis la rondelle de montage (J), jusqu'au corps du robinet (A) et fixer le tout à l'aide de l'écrou de montage (K). **Important: fileter le câble de données dans le trou du support (I) et le côté ouvert de la rondelle (J). Use care to make sure data cable (E) is not pinched.**

2b Option/Option/Option

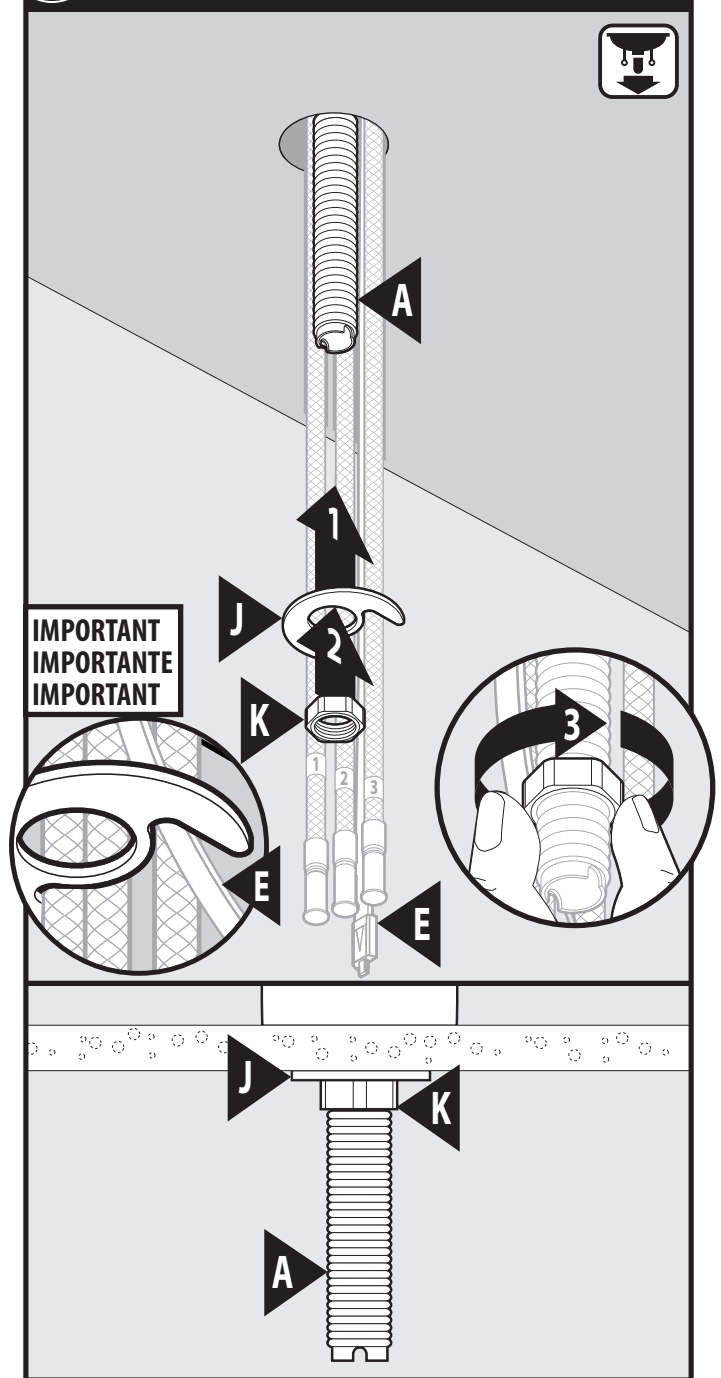

The recommended mounting procedure is to use support bracket (I) with mounting washer (J). It is acceptable to use only mounting washer (J) on sinks that will not accommodate support bracket (I). **Important: use care to make sure data cable (E) is not pinched.**

The recommended mounting procedure is to use support bracket (I) with mounting washer (J). It is acceptable to use only mounting washer (J) on sinks that will not accommodate support bracket (I). **Important: use care to make sure data cable (E) is not pinched.**

The recommended mounting procedure is to use support bracket (I) with mounting washer (J). It is acceptable to use only mounting washer (J) on sinks that will not accommodate support bracket (I). **Important: use care to make sure data cable (E) is not pinched.**

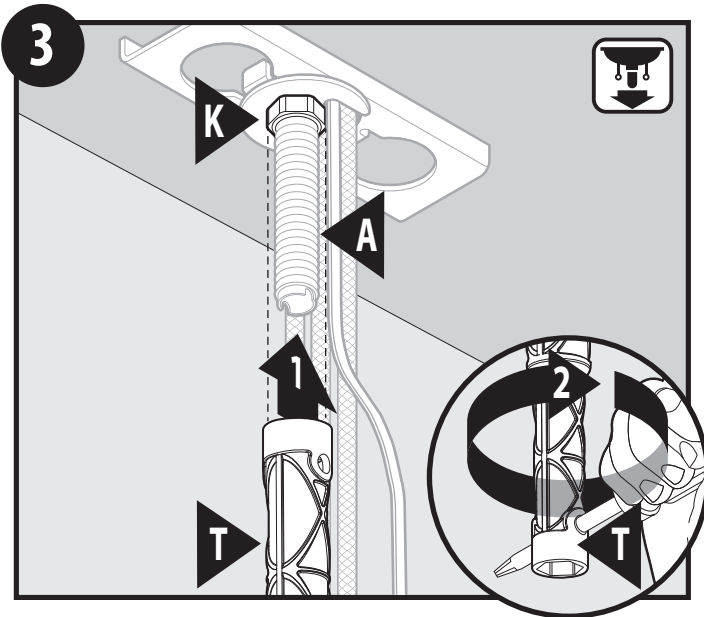

Tighten mounting nut (**K**) with installation tool (**T**). Use screwdriver through hole in installation tool (**T**) to tighten firmly.

Apriete la tuerca de montaje (**K**) con la herramienta de instalación (**T**). Use un destornillador a través del orificio en la herramienta de instalación (**T**) para apretar firmemente.

Serrer l'écrou de montage (**K**) avec l'outil d'installation (**T**). Utiliser un tournevis dans le trou de l'outil d'installation (**T**) pour bien serrer.

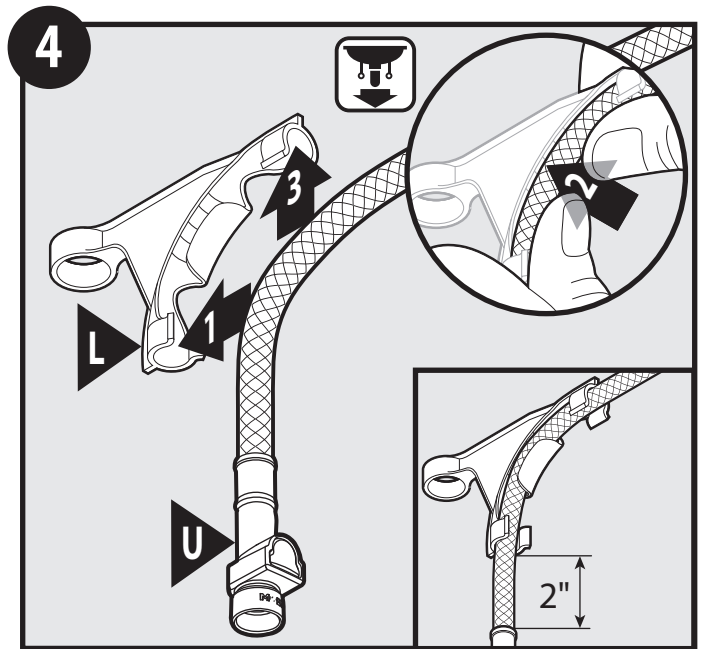

Install pull-down connecting hose bracket (**L**) onto lower end of pull-down connecting hose (**U**), about 2" from end of pull-down connecting hose (**U**).

Instale la ménsula de la manguera extensible (**L**) hacia el extremo inferior de la manguera extensible (**U**), a más o menos 2,5 cm. del extremo de la manguera extensible (**U**).

Installer le support du tuyau de raccord du bec rétractable (**L**) sur la partie inférieure du tuyau de raccord du bec rétractable (**U**), à environ 2 po de l'extrémité du tuyau de raccord du bec rétractable (**U**).

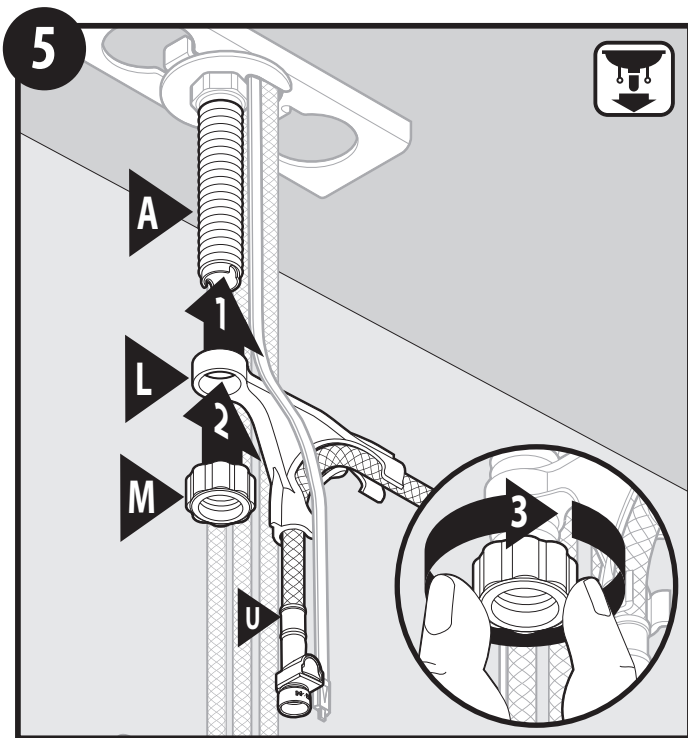

Slide pulldown connecting hose bracket (L) over threaded shank and secure with hose guide nut (M).

Deslice la ménsula de la manguera extensible (L) sobre el vástago roscado y asegúrela con la tuerca de guía de la manguera (M).

Faire glisser le support de tuyau de raccord du bec rétractable (L) sur la tige filetée et le fixer à l'aide de l'écrou du guide-tuyau (M).

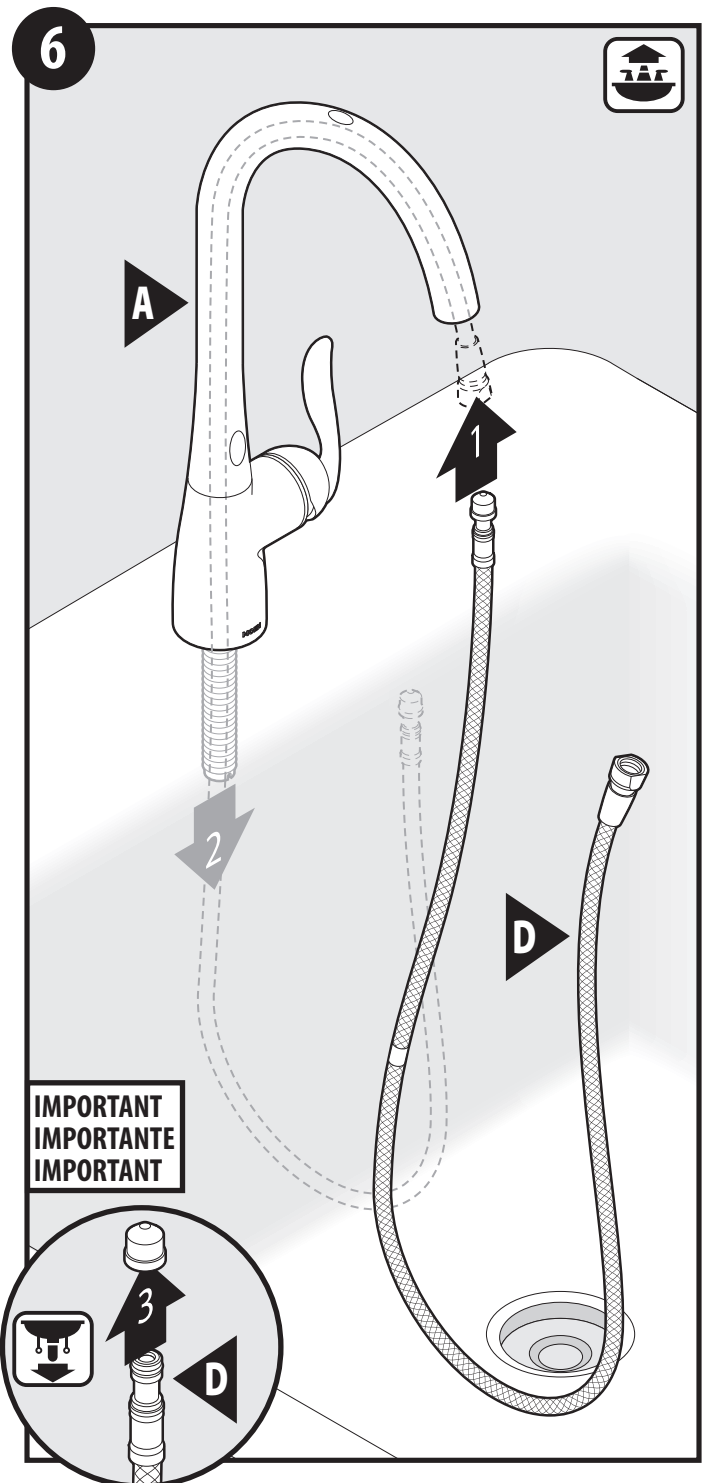

IMPORTANT
IMPORTANT
IMPORTANT

Insert small end of pulldown hose (D) into spout and feed through faucet body (A). Remove and discard protective cap from pulldown hose.

Inserte el extremo pequeño de la manguera extensible (D) en el surtidor y aliméntela a través del cuerpo de la mezcladora (A). Retire y descarte la tapa protectora de la manguera extensible.

Insérer la petite extrémité du tuyau du bec rétractable (D) dans le bec et la faire glisser dans le corps du robinet (A). Retirer et jeter le capuchon protecteur du tuyau du bec rétractable.

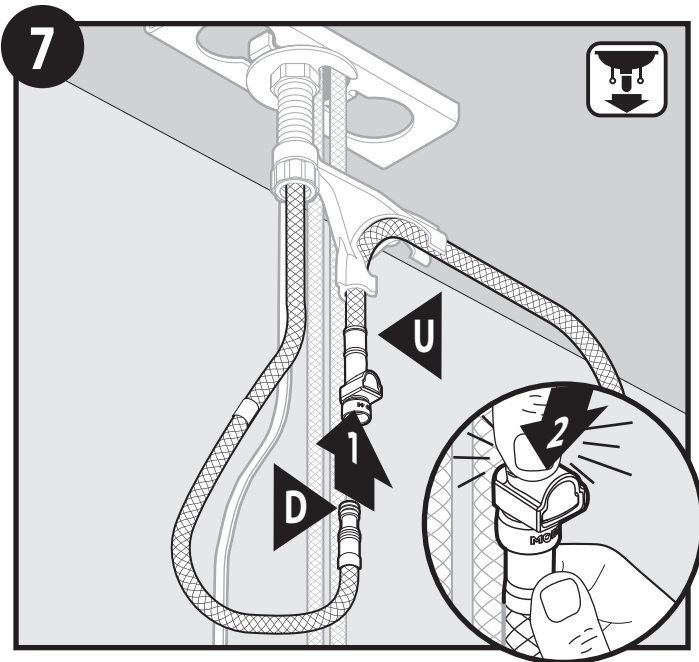

Attach pull-down hose (**D**) into quick connect on pull-down connecting hose (**U**). Push into connector as far as possible. Push the clip in until a "click" is heard. Pull down (**D**) to check that connection is secure.

Conecte la manguera extensible (**D**) en el conector rápido en la manguera extensible (**U**). Empújela lo más profundamente posible dentro del conector. Empuje el clip hacia adentro hasta que se oiga un "clic". Tire de (**D**) para verificar que la conexión sea segura.

Fixer le tuyau du bec rétractable (**D**) dans le raccord rapide du tuyau du raccord de bec rétractable (**U**). Le pousser le plus loin possible dans le raccord. Pousser sur l'étrier jusqu'à ce que vous entendiez un « clic ». Tirer sur (**D**) pour vérifier si le raccord est bien enclenché.

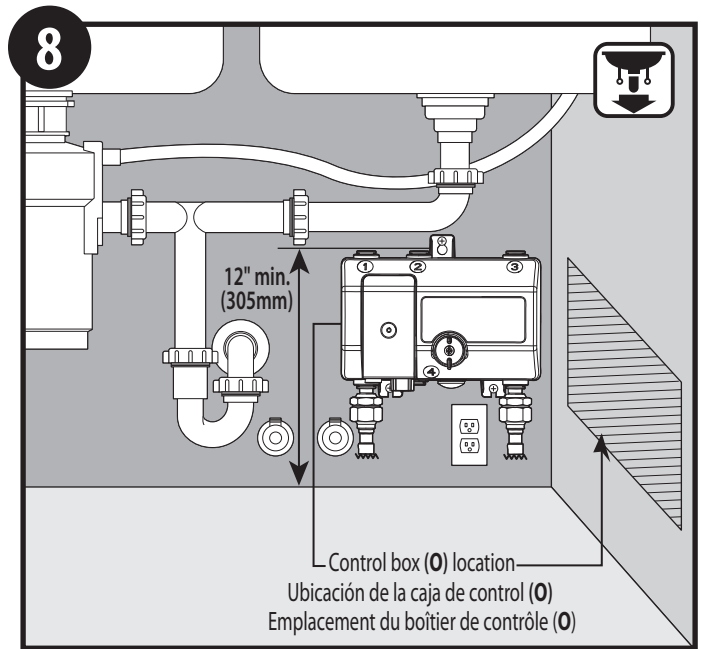

For easier serviceability, mount control box minimum 12" (305mm) above floor.

Select the desired location for control box (**O**). Verify all hoses from faucet, including supply hoses and data cable, will reach connections on control box. If using AC power adapter (not provided) ensure that control box is within 2' (610mm) from outlet.

Para mayor facilidad de servicio, monte la caja de control a una distancia mínima de 12" (305mm) por encima del piso.

Seleccione la ubicación deseada para la caja de control box (**O**). Verifique que todas las mangueras de la mezcladora, inclusive las mangueras de alimentación y el cable de datos, lleguen a las conexiones en la caja de control. Si se va a utilizar un adaptador de corriente CA (no provisto) asegúrese de que la caja de control esté a no más de 2' (610 mm) del tomacorriente.

Pour faciliter les réparations, installer le boîtier de contrôle au moins 305 mm (12 po) au-dessus du sol.

Choisir l'emplacement désiré pour le boîtier de contrôle (**O**). Vérifier si tous les tuyaux du robinet, y compris les tuyaux d'alimentation et le câble de données, se rendront au boîtier de contrôle. Si un adaptateur c.a. (non fourni) est utilisé, s'assurer que le boîtier de contrôle est à moins de 61 cm (2 pi) de la sortie.

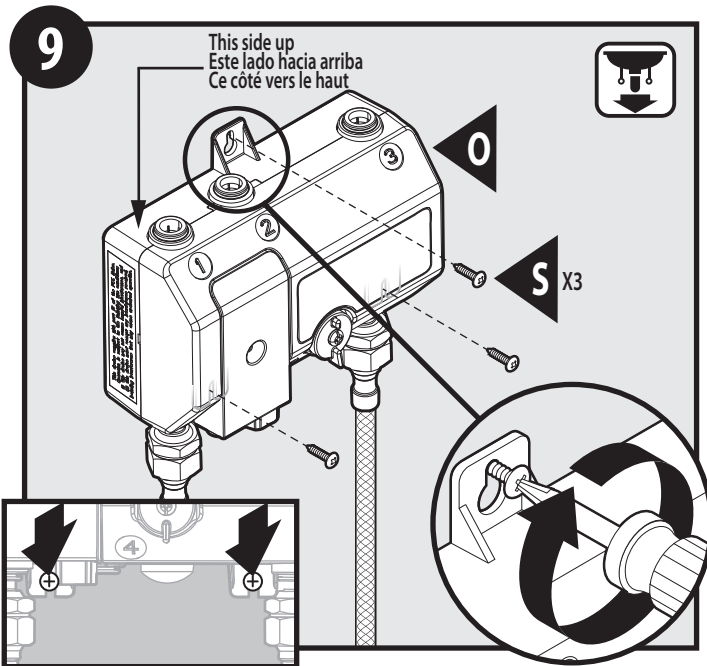

Secure control box (O) to wall with provided mounting screws (S). If installing into drywall use appropriate anchors and screws (not provided).

Asegure la caja de control (O) a la pared con los tornillos de montaje provistos (S). Si la instala sobre pared en seco, utilice anclajes y tornillos apropiados (no provistos).

Fixer le boîtier de contrôle (O) au mur avec les vis de montage fournies (S). Si l'installation est effectuée sur une cloison sèche, utiliser les dispositifs d'ancrage et les vis appropriés (non fournis).

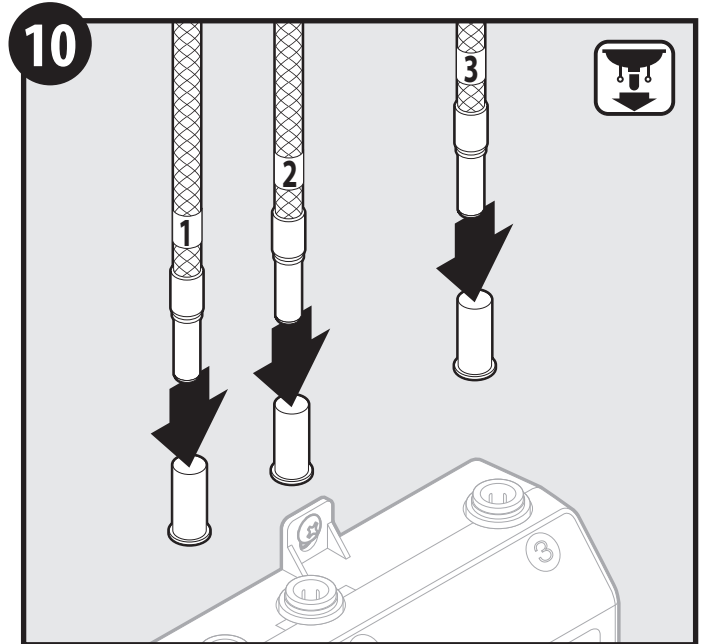

Remove and discard protective caps from hoses (1, 2, 3).

Retire y descarte las tapas protectoras de las mangueras (1, 2, 3).

Retirer et jeter les capuchons protecteurs des tuyaux (1, 2, 3).

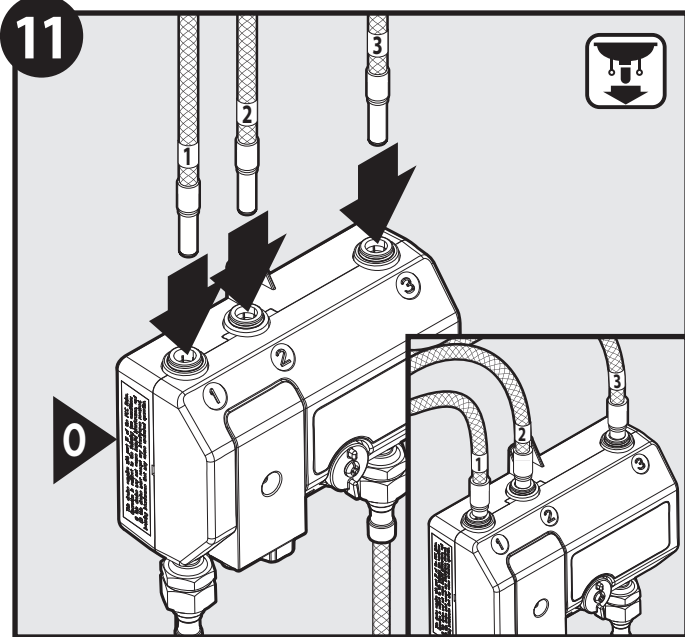

Insert faucet hoses (1, 2, 3) to corresponding push fit connections on top of control box (O). Gently pull on hoses to ensure hoses are fully inserted and secure.

Insert faucet hoses (1, 2, 3) to corresponding push fit connections on top of control box (O). Gently pull on hoses to ensure hoses are fully inserted and secure.

Insert faucet hoses (1, 2, 3) to corresponding push fit connections on top of control box (O). Gently pull on hoses to ensure hoses are fully inserted and secure.

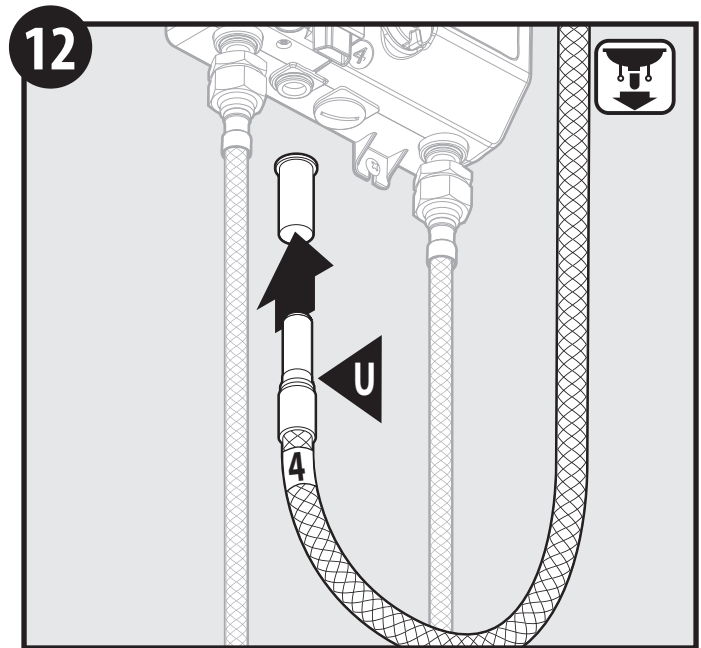

Remove and discard protective cap from pull-down connecting hose (U).

Retire y descarte la tapa protectora de la manguera extensible (U).

Retirer et jeter le capuchon protecteur du tuyau de raccord du bec rétractable (U).

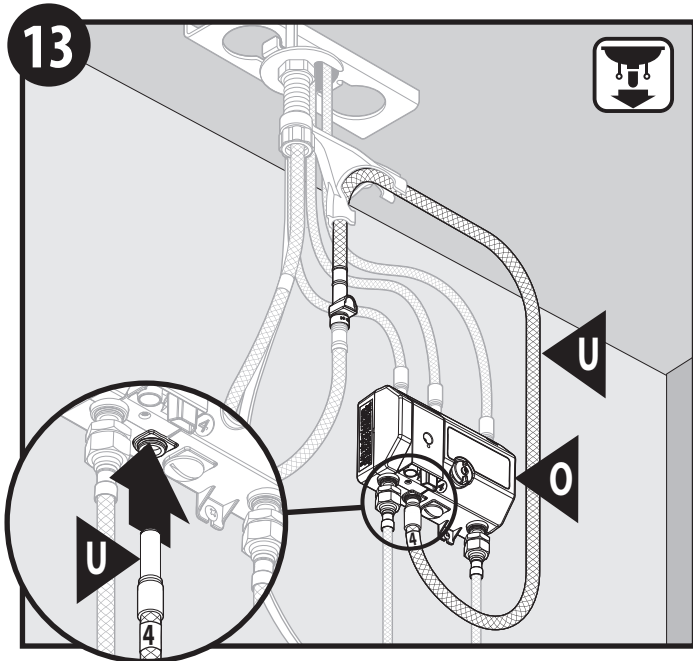

Insert pull-down connecting hose (U) (number 4) into corresponding push fit connection on bottom of control box (O). Gently pull on hose to ensure connection is secure.

Insert pull-down connecting hose (U) (number 4) into corresponding push fit connection on bottom of control box (O). Gently pull on hose to ensure connection is secure.

Insert pull-down connecting hose (U) (number 4) into corresponding push fit connection on bottom of control box (O). Gently pull on hose to ensure connection is secure.

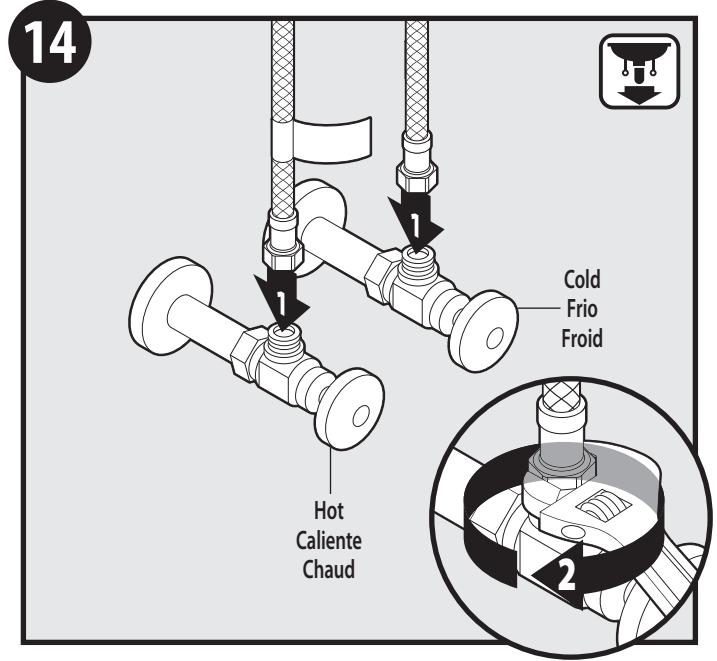

Connect hot and cold hoses to supply valves.

Conecte las mangueras de agua fría y caliente a las válvulas de alimentación.

Raccorder les tuyaux d'eau chaude et d'eau froide aux robinets d'alimentation.

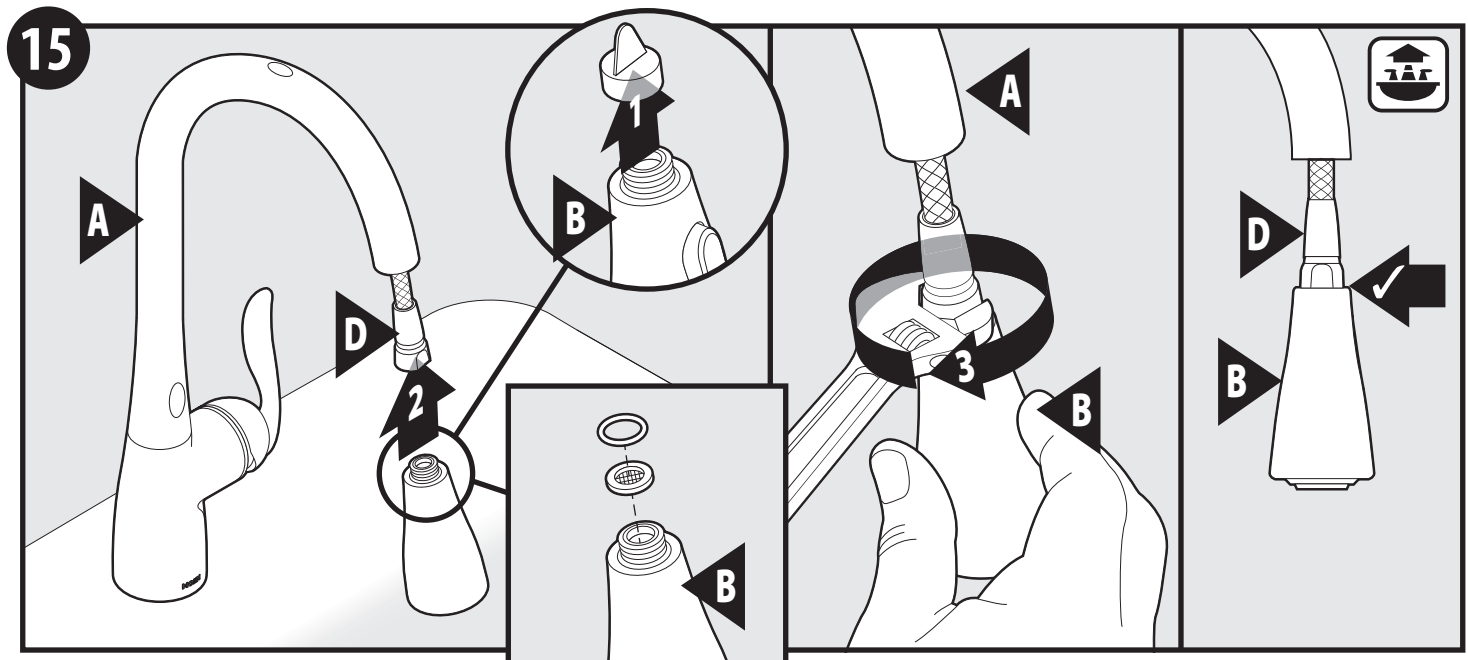

Remove and discard protective cap from wand (B) (make sure rubber washer and screen are in place). Install spray wand (B) to upper connection of pull-down hose (D) Tighten hose nut until flush with spray wand. DO NOT overtighten.

Retire y descarte la tapa protectora de la varilla (B) (asegúrese de que la arandela de caucho y el filtro estén en su lugar). Instale la varilla rociadora (B) a la conexión superior de la manguera extensible (D) Apriete la tuerca de la manguera hasta que quede a ras con la varilla rociadora. NO apriete de más.

Retirer et jeter le capuchon protecteur du bec de pulvérisation (B) (s'assurer que la rondelle en caoutchouc et le tamis sont en place). Installer le bec de pulvérisation (B) sur le raccord supérieur du tuyau de bec rétractable (D). Serrer l'écrou de tuyau jusqu'à égalité avec le bec de pulvérisation. NE PAS trop serrer.

16

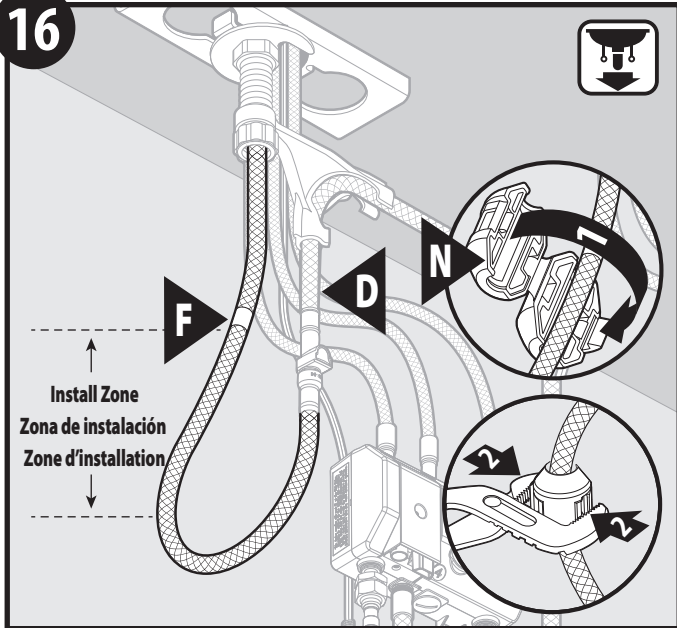

Locate hose weight locator mark (F) on pull-down hose (D). Install hose weight (N) just above start of loop curvature in hose on the same side of hose as locator mark. Pliers can be used for installation assistance.

Ubique la marca de ubicación del peso de la manguera (F) en la manguera extensible (D). Instale el peso de la manguera (N) justo arriba del comienzo de la curva del lazo de la manguera y del mismo lado de la manguera que la marca de ubicación. Pliers can be used for installation assistance.

Trouver la marque de l'indicateur du poids du tuyau (F) sur le tuyau de bec rétractable (D). Installer le poids du tuyau (N) juste au-dessus d'où commence la courbure de la boucle du tuyau, du même côté que la marque de l'indicateur sur le tuyau. Pliers can be used for installation assistance.

17a

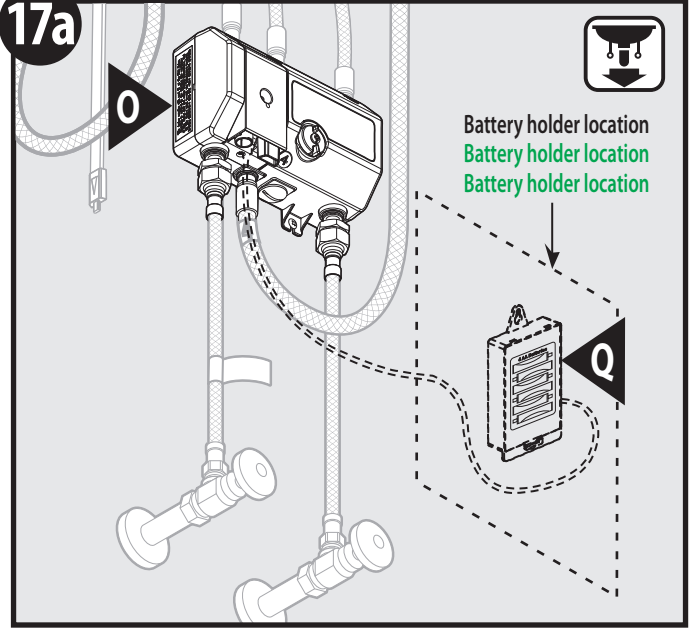

Select location for battery holder (Q). Before installation, verify that the battery holder wire will reach connection on bottom of control box (O).

Select location for battery holder (Q). Before installation, verify that the battery holder wire will reach connection on bottom of control box (O).

Select location for battery holder (Q). Before installation, verify that the battery holder wire will reach connection on bottom of control box (O).

17b

If using AC power adapter (not provided) ensure that control box is within 2 feet (610mm) of AC outlet.

Si utiliza un adaptador de corriente CA (no provisto), asegúrese de que la caja de control esté a menos de 2 pies (610 mm) del tomacorriente CA.

Si un adaptateur c.a. (non fourni) est utilisé, s'assurer que le boîtier de contrôle est à moins de 2 pi (610 mm) de la sortie c.a.

18

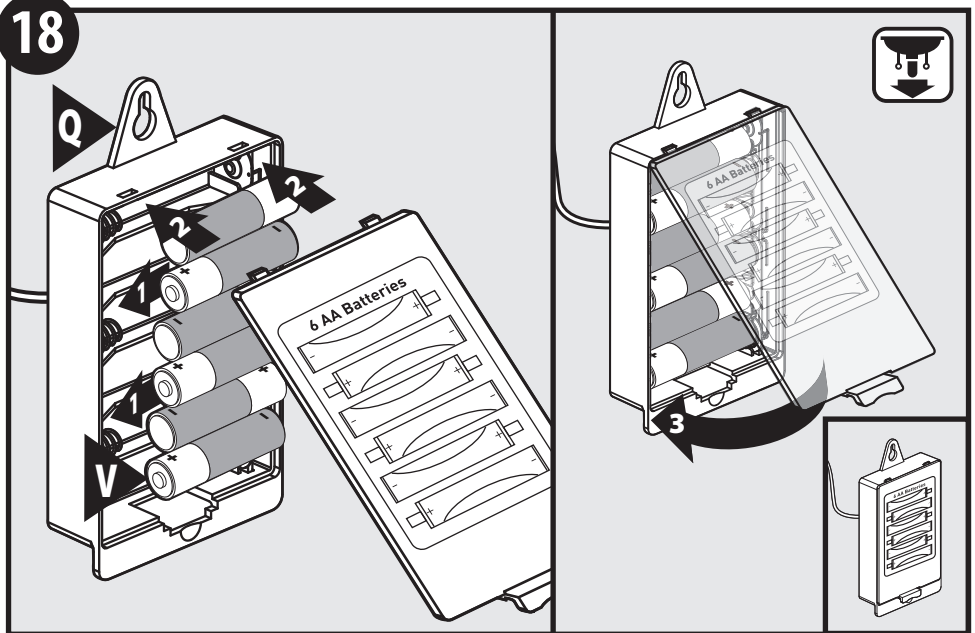

Remove cover from battery holder (Q) and install six AA batteries (V) in the same orientation as shown on cover. For best performance, use non-rechargeable alkaline batteries. Reinstall battery holder cover.

Remove cover from battery holder (Q) and install six AA batteries (V) in the same orientation as shown on cover. For best performance, use non-rechargeable alkaline batteries. Reinstall battery holder cover.

Remove cover from battery holder (Q) and install six AA batteries (V) in the same orientation as shown on cover. For best performance, use non-rechargeable alkaline batteries. Reinstall battery holder cover.

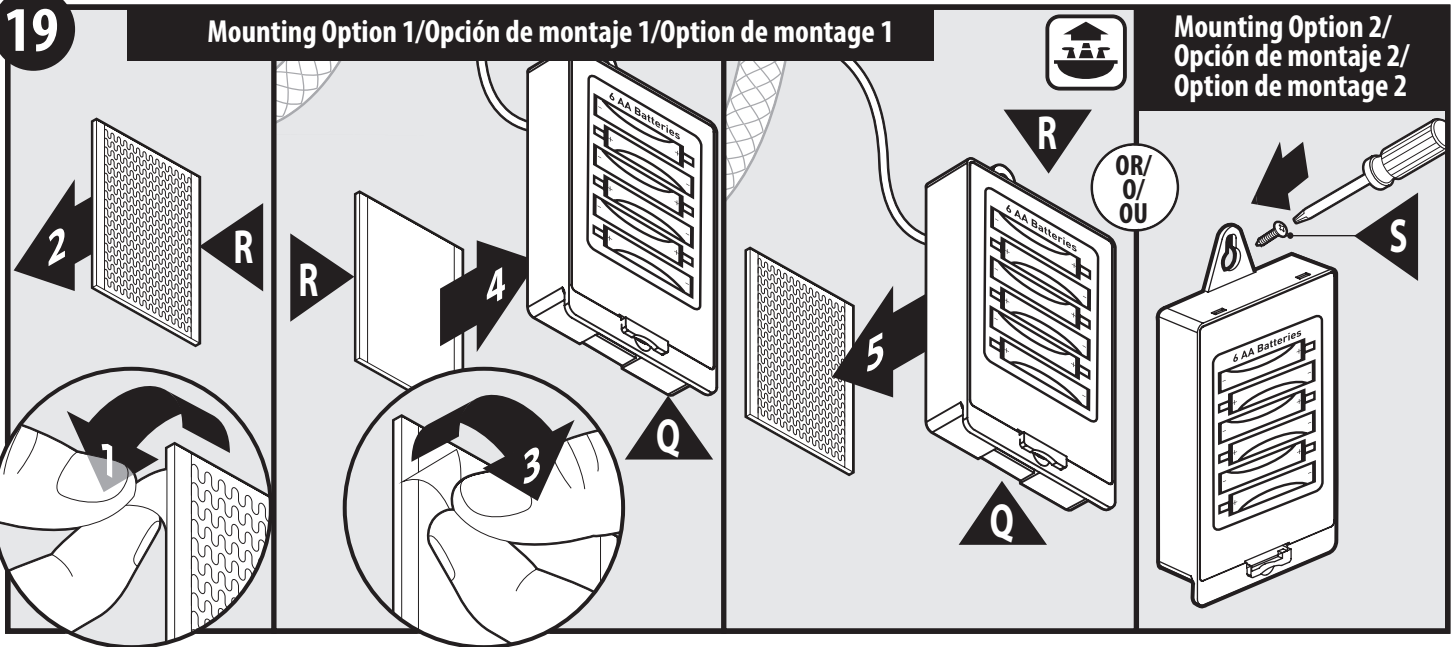

Attach battery holder (Q) to wall with hook & loop fastener (R). First, attach one side of hook and loop fastener to wall. Then attach other piece to back of battery holder. **Option:** Attach battery holder to wall with screw provided.

Attach battery holder (Q) to wall with hook & loop fastener (R). First, attach one side of hook and loop fastener to wall. Then attach other piece to back of battery holder. **Option:** Attach battery holder to wall with screw provided.

Attach battery holder (Q) to wall with hook & loop fastener (R). First, attach one side of hook and loop fastener to wall. Then attach other piece to back of battery holder. **Option:** Attach battery holder to wall with screw provided.

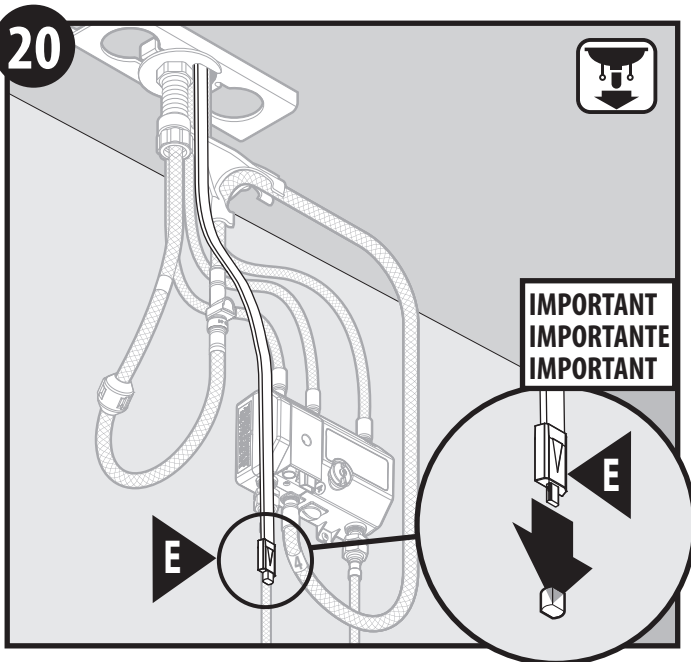

Remove and discard protective cover from data cable (E).
Retire y descarte la tapa protectora del cable de datos (E).
Retirer et jeter le couvercle protecteur du câble de données (E).

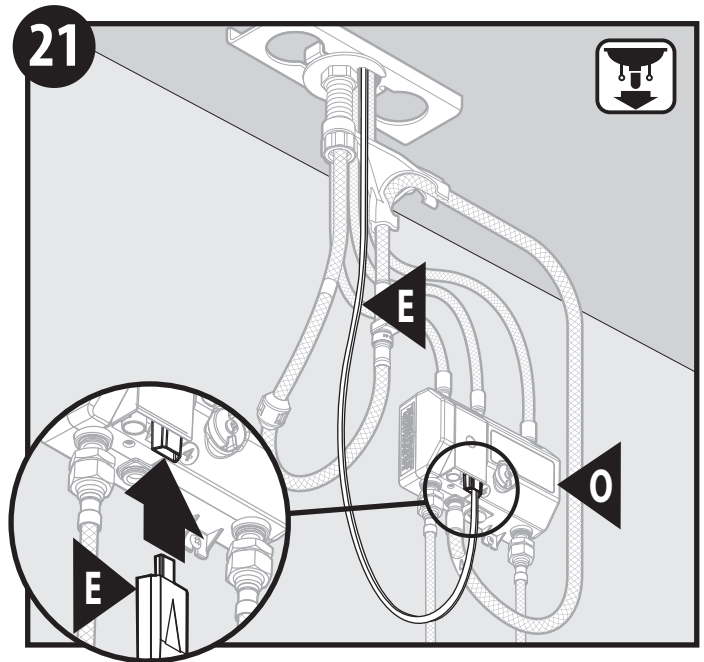

Insert data cable (E) to data port on bottom of control box (O). Push to secure.
Inserte el cable de datos (E) al puerto de datos en la parte inferior de la caja de control (O). Empuje para asegurarlo.
Insérer le câble de données (E) dans le port de données sur la partie inférieure du boîtier de contrôle (O). Poussez sur le câble pour qu'il soit bien fixé.

22 IMPORTANT/IMPORTANTE/IMPORTANT



Before connecting battery holder, ensure that no objects are within 3 feet of faucet. Objects could interfere with start up process. Remove both protective labels from sensors on spout.

Before connecting battery holder, ensure that no objects are within 3 feet of faucet. Objects could interfere with start up process. Remove both protective labels from sensors on spout.

Before connecting battery holder, ensure that no objects are within 3 feet of faucet. Objects could interfere with start up process. Remove both protective labels from sensors on spout.

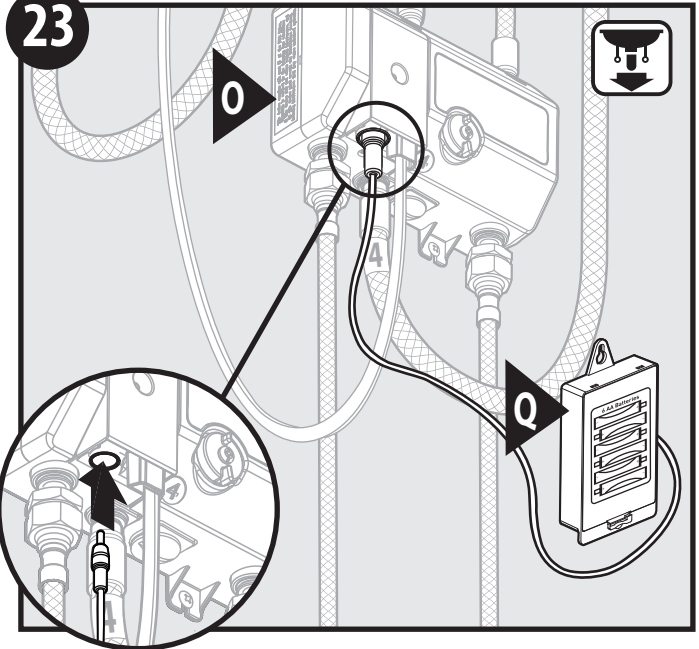
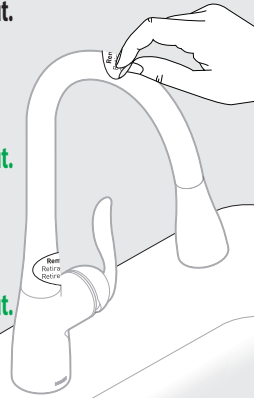

Insert battery holder (Q) cable into control box (O) power port. Ensure cable is pushed all the way into the control box.

Insert battery holder (Q) cable into control box (O) power port. Ensure cable is pushed all the way into the control box.

Insert battery holder (Q) cable into control box (O) power port. Ensure cable is pushed all the way into the control box.

24



Once battery holder cable is connected, the blue light on front of faucet will flash. After 10 seconds, the blue light will flash again. The start up process is now complete.

Once battery holder cable is connected, the blue light on front of faucet will flash. After 10 seconds, the blue light will flash again. The start up process is now complete.

Once battery holder cable is connected, the blue light on front of faucet will flash. After 10 seconds, the blue light will flash again. The start up process is now complete.

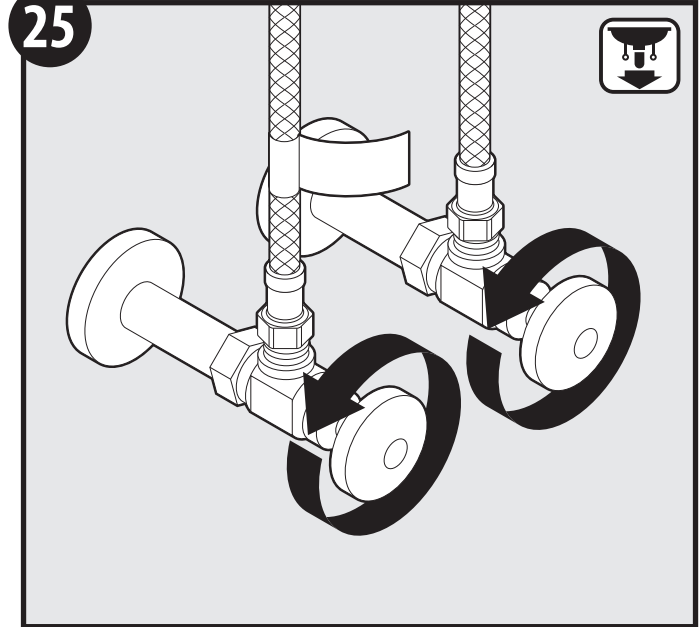

Turn on water supply.

Abra el suministro de agua.

Ouvrir l'alimentation en eau.

26

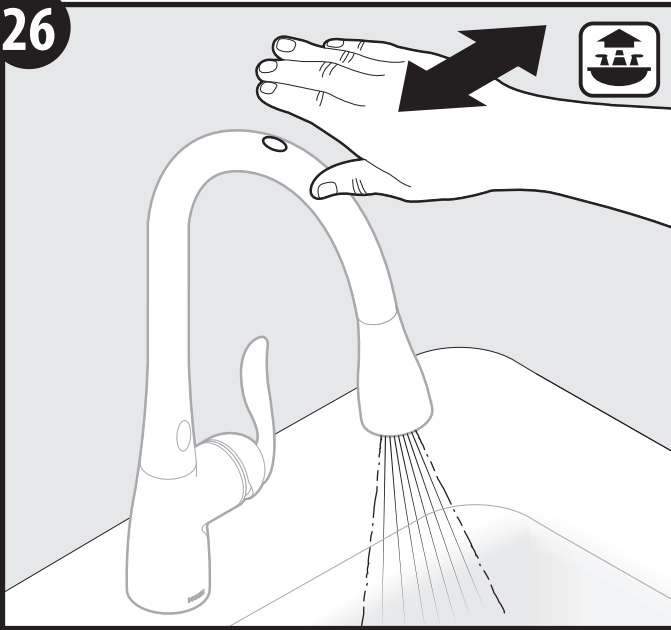

Check to ensure wave sensor is working properly. Move hand over wave sensor to test that water will turn on. Move hand over wave sensor again to turn water off.

Verifique que el sensor de ondas esté funcionando correctamente. Mueva la mano frente al sensor para ver si sale el agua. Mueva la mano frente al sensor nuevamente para cerrar el agua.

S'assurer que le détecteur de mouvement fonctionne de manière appropriée. Passer la main au-dessus du détecteur de mouvement pour vérifier que le robinet fait couler l'eau. Passer de nouveau la main au-dessus du détecteur de mouvement pour fermer l'eau.

28

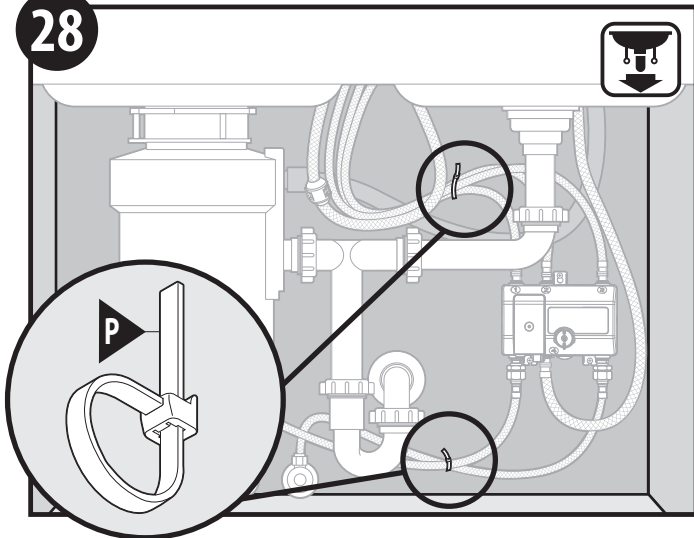

Use zip ties (P) if desired to manage faucet hoses, data cable and battery holder cable. **Do not zip tie pulldown hose (D).** Check to ensure pulldown hose movement is not obstructed.

Use zip ties (P) if desired to manage faucet hoses, data cable and battery holder cable. **Do not zip tie pulldown hose (D).** Check to ensure pulldown hose movement is not obstructed.

Use zip ties (P) if desired to manage faucet hoses, data cable and battery holder cable. **Do not zip tie pulldown hose (D).** Check to ensure pulldown hose movement is not obstructed.

27

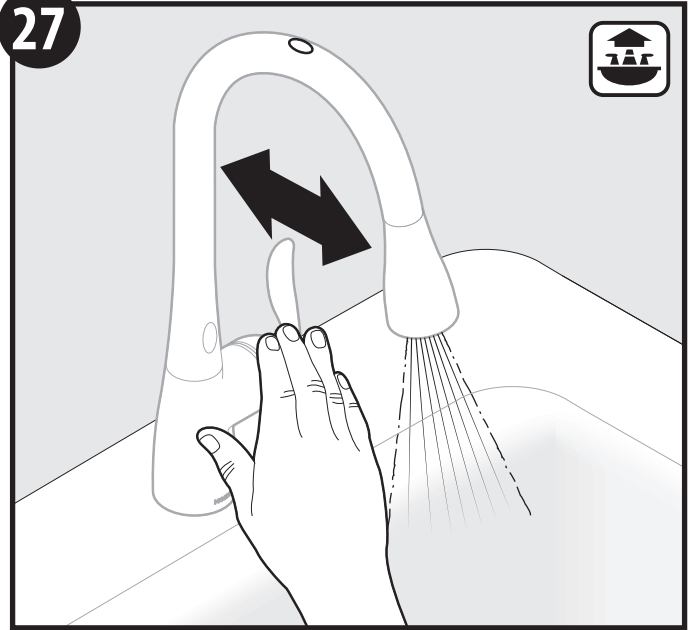

Check to ensure ready sensor is working properly. Place hand in front of ready sensor to test that water will run.

Verifique que el sensor listo esté funcionando correctamente. Coloque la mano frente al sensor listo para verificar que el agua corra.

S'assurer que le détecteur de présence fonctionne de manière appropriée. Placer la main devant le détecteur de présence pour vérifier si le robinet fait couler l'eau.

Installation Complete

Instalación Completa

Installation Terminée

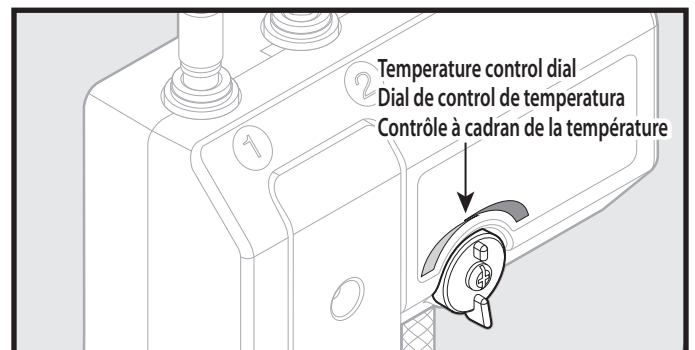

Temperature in electronics mode will be factory preset to luke warm. Adjust with temperature control dial as needed.

La temperatura en modo electrónico estará ajustada de fábrica a tibio. Ajuste con el dial de control de temperatura como sea necesario.

La température en mode électronique sera pré réglée en usine à tiède. Régler la température à l'aide du cadran de contrôle, au besoin.

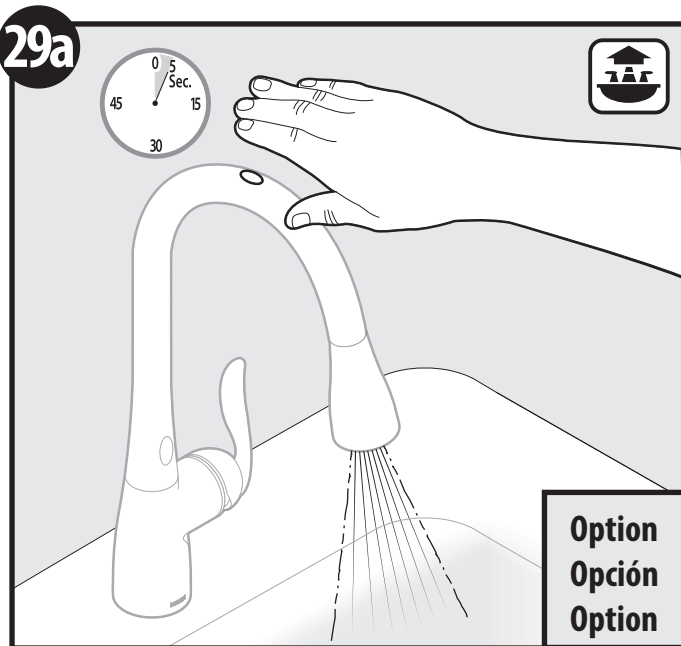

To disable both sensors: Hold your hand directly above the wave sensor for approximately five (5) seconds. Water will begin to run and then turn off, indicating MotionSense Hands-Free has been disabled.

To enable both sensors: Simply repeat the process, holding your hand above the wave sensor for five (5) seconds until water begins to run again.

Para desactivar ambos sensores: Mantenga la mano directamente encima del sensor de ondas durante aproximadamente cinco (5) segundos. El agua comenzará a correr y luego se cortará, indicando que el MotionSense Hands-Free ha sido desactivado.

Para activar ambos sensores: Simplemente repita el proceso, manteniendo la mano sobre el sensor de ondas por cinco (5) segundos hasta que el agua comience a correr nuevamente.

Pour désactiver les deux détecteurs: laissez votre main directement au-dessus du détecteur de mouvement pendant environ cinq (5) secondes. L'eau commencera à couler, puis se fermera, indiquant que le dispositif mains libres MotionSense a été désactivé.

Pour activer les deux détecteurs: répéter simplement le processus, en laissant votre main au-dessus du capteur de mouvement pendant cinq (5) secondes, jusqu'à ce que l'eau recommence à couler.

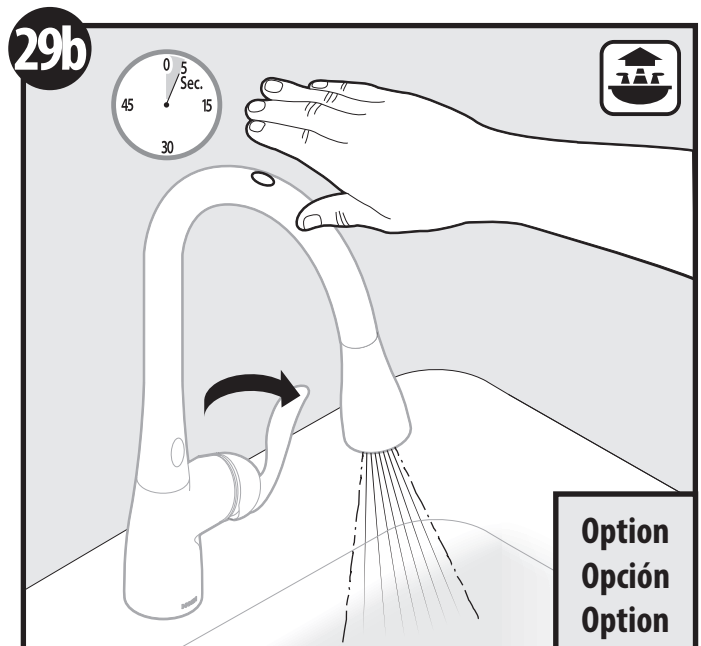

To disable Ready Sensor only: Open handle, hold hand above wave sensor for 5 seconds. To enable the Ready Sensor, repeat the same process.

Para desactivar el sensor listo solamente: Abra el monomando, mantenga la mano sobre el sensor de ondas por 5 segundos. Para activar el sensor listo, repita el mismo proceso.

Pour désactiver le détecteur de présence seulement: ouvrir la poignée et laisser la main au-dessus du détecteur de mouvement pendant cinq secondes. Pour activer le détecteur de présence, répéter le même processus.

Performance check light on control box will illuminate in the patterns shown if service is required. For assistance, call 1-800-BUY-MOEN.

Performance check light on control box will illuminate in the patterns shown if service is required. For assistance, call 1-800-BUY-MOEN.

Performance check light on control box will illuminate in the patterns shown if service is required. For assistance, call 1-800-BUY-MOEN.

Performance Check/Verificación de funcionamiento/Verification du fonctionnement

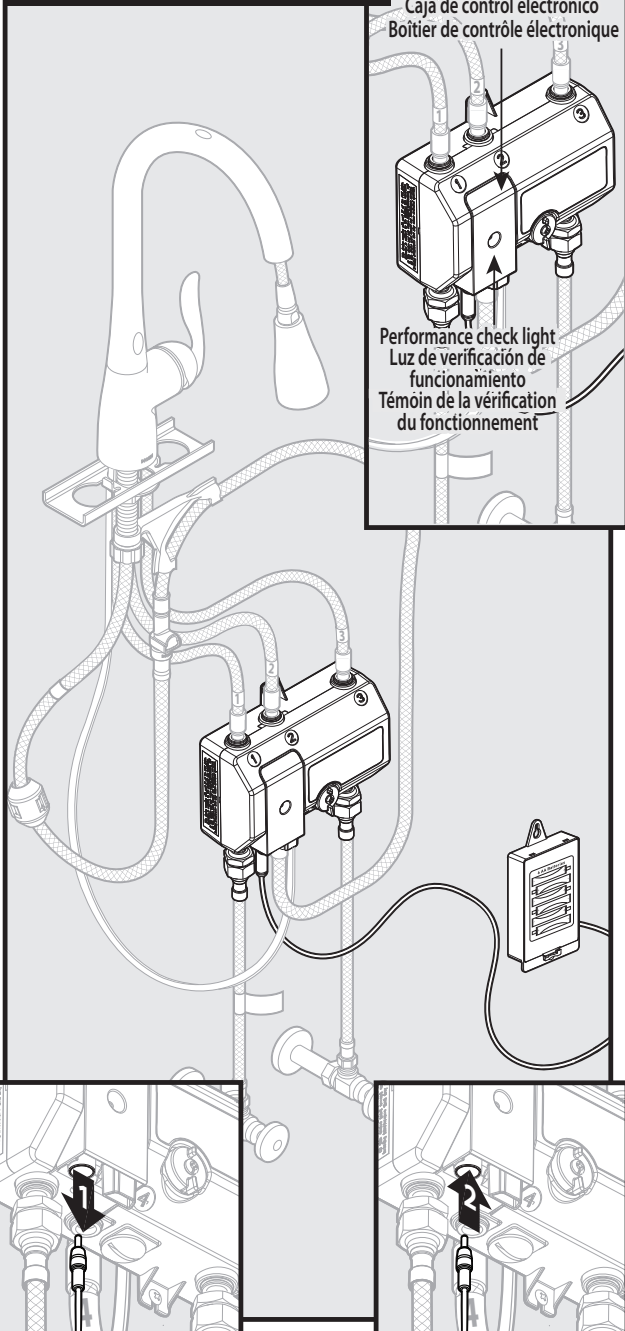

Electronic control box
Caja de control electrónico
Boîtier de contrôle électronique

Performance check light
Luz de verificación de funcionamiento
Témoin de la vérification du fonctionnement

Performance Check/Verificación de funcionamiento/Verification du fonctionnement

- = Control box/Caja de control /Boîtier de contrôle
Light is on constantly/La luz está continuamente encendida/Le témoin reste allumé
- — — — = Electronics box/Caja de electrónica/Boîtier électronique
Light Flashes, 1 long, 1 short/La luz parpadea, 1 largo, 1 corto/Clignotements du témoin : un long, un court
- - - - = Spout/Surtidor/Bec
Light Flashes, 3 short/La luz parpadea, 3 cortos/Clignotements du témoin : trois courts

Control box/Caja de control/Boîtier de contrôle

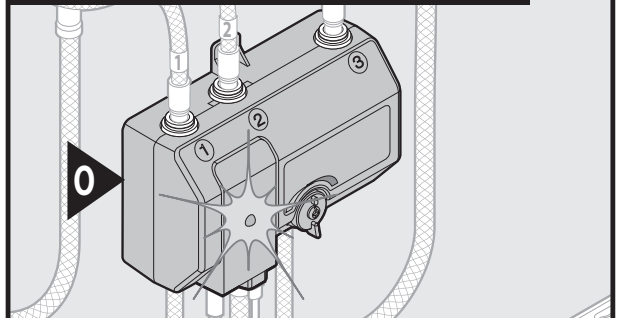

Electronics box/Caja de electrónica/Boîtier électronique

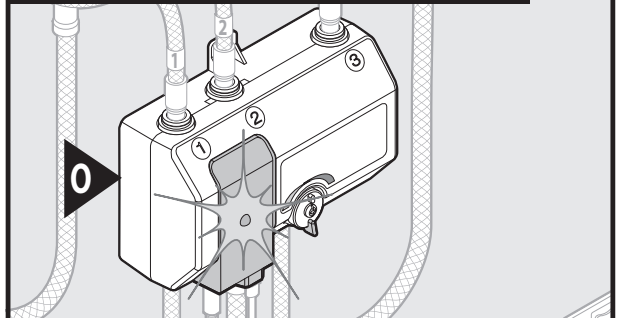

Spout/Surtidor/Bec

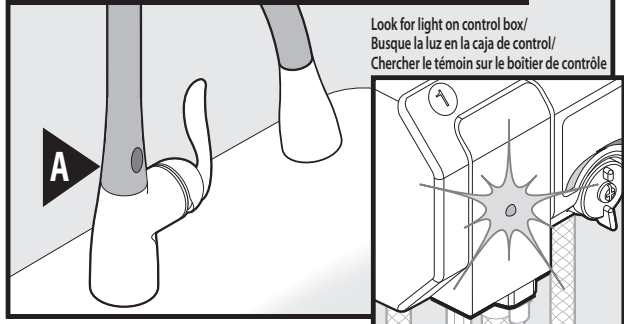

Look for light on control box/
Busque la luz en la caja de control/
Chercher le témoin sur le boîtier de contrôle

Disconnect power cable, wait 30 seconds and reconnect.

Desconecte el cable de alimentación, espere 30 segundos y vuelva a conectar.

Débrancher le câble électrique, attendre 30 secondes et le rebrancher.

If Sensors are not working, please disconnect the power cable for 30 seconds and reconnect. This will activate the Performance Check and reset the sensors.

If Sensors are not working, please disconnect the power cable for 30 seconds and reconnect. This will activate the Performance Check and reset the sensors.

If Sensors are not working, please disconnect the power cable for 30 seconds and reconnect. This will activate the Performance Check and reset the sensors.

A1 Low Flow/Flujo bajo/Faible débit

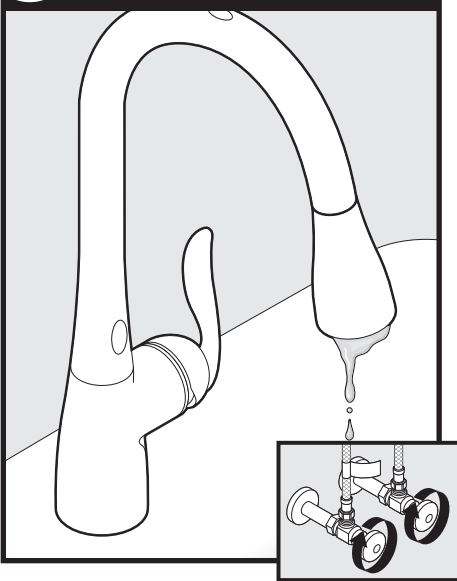

If low flow, turn off water at stops before cleaning filter.

Si el flujo es bajo, corte el agua en las llaves de paso antes de limpiar el filtro.

Si le débit est faible, couper l'alimentation en eau aux robinets d'arrêt avant de nettoyer le filtre.

A4

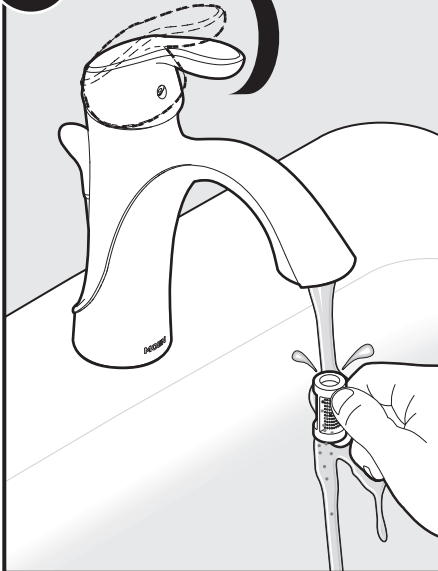

Rinse debris from filter screen.

Enjuague las impurezas de la malla del filtro.

Rincer le filtre pour enlever tous les débris.

A2

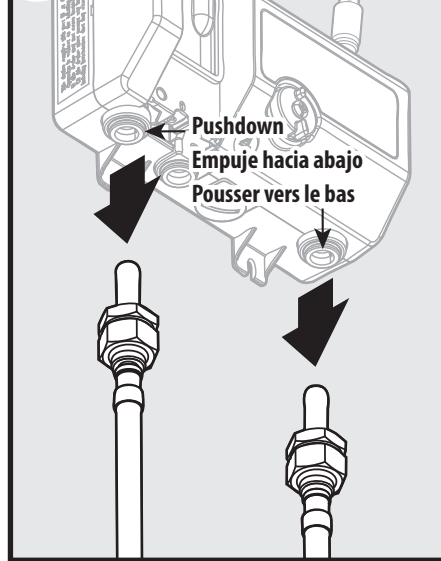

To remove in-line filter, push down on retainer ring and pull up on outlet hose (#2).

Para remover el filtro en línea, empuje hacia abajo sobre el anillo retenedor y tire hacia arriba de la manguera de salida (#2).

Pour retirer le filtre intégré, pousser vers le bas l'anneau de retenue et tirer vers le haut le tuyau de sortie (#2).

A3

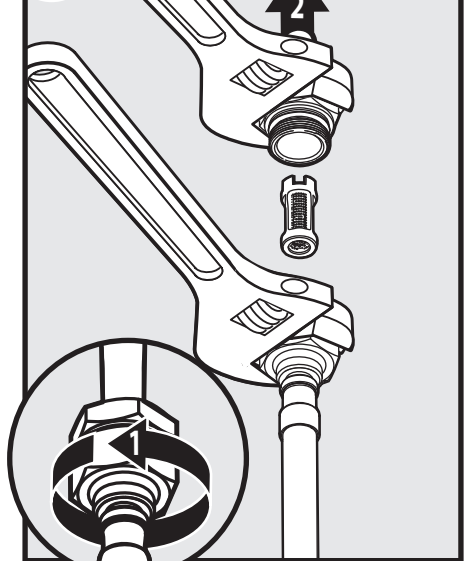

Hold #2 hose with a wrench at top of filter connection. Unscrew filter with second wrench.

Sostenga la manguera #2 con una llave en la parte superior de la conexión del filtro. Destornille el filtro con una segunda llave.

Maintenir le tuyau #2 sur le dessus du raccord du filtre à l'aide d'une clé. Dévisser le filtre avec la deuxième clé.

A5

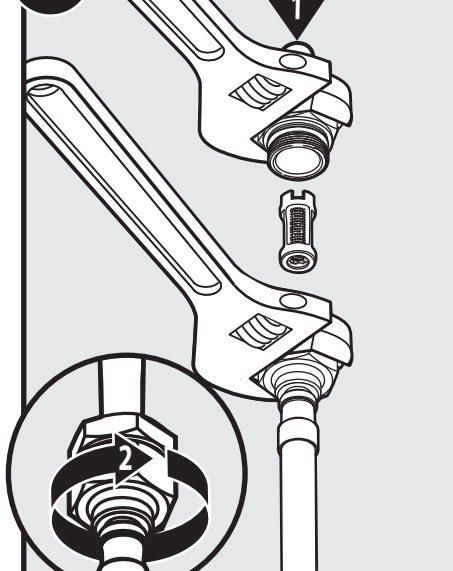

Reassemble filter into housing and tighten using 2 wrenches.

Vuelva a armar el filtro dentro del bastidor y apriete usando 2 llaves.

Réinstaller le filtre dans le boîtier et serrer à l'aide des deux clés.

A6

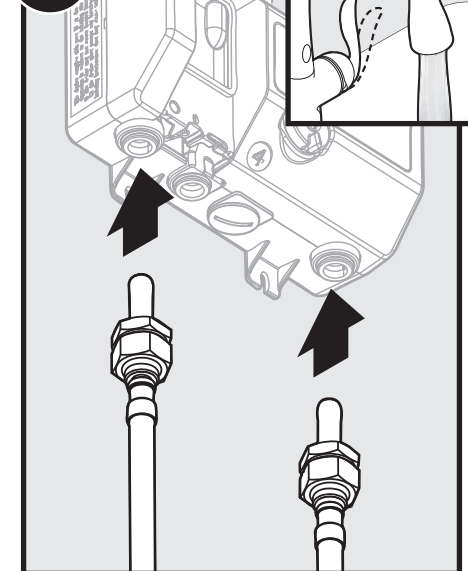

Insert #2 hose assembly into control box.

Inserte el conjunto de la manguera #2 en la caja de control.

Insérer l'assemblage du tuyau no 2 dans le boîtier de contrôle.

Trouble Shooting -Water Shut-Off With Sensors

Trouble Shooting -Water Shut-Off With Sensors

Trouble Shooting -Water Shut-Off With Sensors

Symptom: Water keeps flowing through the spray wand when the handle is in closed position and water does not turn off by waving hand over top wave sensor.

Symptom: Water keeps flowing through the spray wand when the handle is in closed position and water does not turn off by waving hand over top wave sensor.

Symptom: Water keeps flowing through the spray wand when the handle is in closed position and water does not turn off by waving hand over top wave sensor.

B1

Disconnect the battery holder cable (Q). Check all the batteries (V) are installed in the correct orientation (Refer to step 18) Check the data cable (E) is connected properly. Ensure it is pushed all the way into the control box (O). (Refer to step 21) Plug-in the battery holder cable (Q) and ensure it is pushed all the way into the control box (O). (Refer to step 23). Clear people and objects within 3 feet of the faucet sensors. Keep clear during the 10 second start-up process. If the water stops flowing the symptom is resolved.

Disconnect the battery holder cable (Q). Check all the batteries (V) are installed in the correct orientation (Refer to step 18) Check the data cable (E) is connected properly. Ensure it is pushed all the way into the control box (O). (Refer to step 21) Plug-in the battery holder cable (Q) and ensure it is pushed all the way into the control box (O). (Refer to step 23). Clear people and objects within 3 feet of the faucet sensors. Keep clear during the 10 second start-up process. If the water stops flowing the symptom is resolved.

Disconnect the battery holder cable (Q). Check all the batteries (V) are installed in the correct orientation (Refer to step 18) Check the data cable (E) is connected properly. Ensure it is pushed all the way into the control box (O). (Refer to step 21) Plug-in the battery holder cable (Q) and ensure it is pushed all the way into the control box (O). (Refer to step 23). Clear people and objects within 3 feet of the faucet sensors. Keep clear during the 10 second start-up process. If the water stops flowing the symptom is resolved.

B2

If the water is still flowing, unplug the battery holder cable (Q), wait 30 seconds, then plug in the battery holder cable and ensure it is pushed all the way into the control box (O). Clear people and objects within 3 feet of the faucet sensors. Keep clear during the 10 second start-up process. Look for the flashing RED light on the control box (O) at start-up. If no RED light was visible, call consumer service (1-800-BUY-MOEN, 1-800-289-6636).

If the water is still flowing, unplug the battery holder cable (Q), wait 30 seconds, then plug in the battery holder cable and ensure it is pushed all the way into the control box (O). Clear people and objects within 3 feet of the faucet sensors. Keep clear during the 10 second start-up process. Look for the flashing RED light on the control box (O) at start-up. If no RED light was visible, call consumer service (1-800-BUY-MOEN, 1-800-289-6636).

If the water is still flowing, unplug the battery holder cable (Q), wait 30 seconds, then plug in the battery holder cable and ensure it is pushed all the way into the control box (O). Clear people and objects within 3 feet of the faucet sensors. Keep clear during the 10 second start-up process. Look for the flashing RED light on the control box (O) at start-up. If no RED light was visible, call consumer service (1-800-BUY-MOEN, 1-800-289-6636).

B3

If flashing RED light was visible but water is still flowing, unplug the battery holder cable (Q), wait 30 seconds, then plug in the battery holder cable and ensure it is pushed all the way into the control box (O). Clear people and objects within 3 feet of the faucet sensors. Keep clear during the 10 second start-up process. If the water stops flowing the symptom is resolved.

If flashing RED light was visible but water is still flowing, unplug the battery holder cable (Q), wait 30 seconds, then plug in the battery holder cable and ensure it is pushed all the way into the control box (O). Clear people and objects within 3 feet of the faucet sensors. Keep clear during the 10 second start-up process. If the water stops flowing the symptom is resolved.

If flashing RED light was visible but water is still flowing, unplug the battery holder cable (Q), wait 30 seconds, then plug in the battery holder cable and ensure it is pushed all the way into the control box (O). Clear people and objects within 3 feet of the faucet sensors. Keep clear during the 10 second start-up process. If the water stops flowing the symptom is resolved.

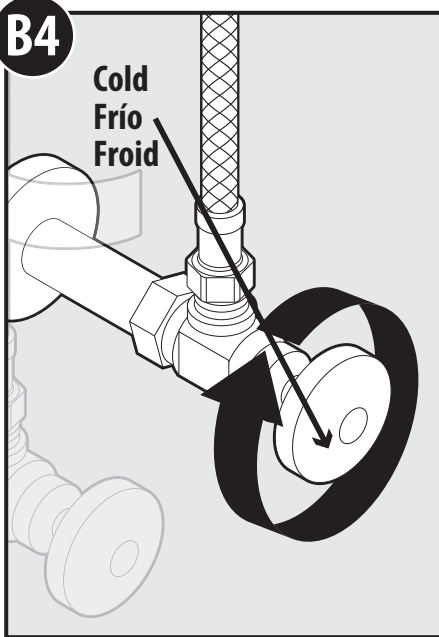

If water is still flowing, turn off the cold water supply. So only HOT water is flowing through the spray wand.

If water is still flowing, turn off the cold water supply. So only HOT water is flowing through the spray wand.

If water is still flowing, turn off the cold water supply. So only HOT water is flowing through the spray wand.

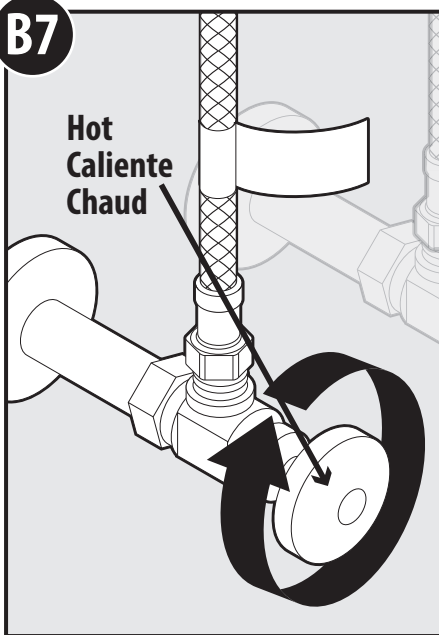

If water is still flowing, turn off the hot water supply so water is no longer flowing.

If water is still flowing, turn off the hot water supply so water is no longer flowing.

If water is still flowing, turn off the hot water supply so water is no longer flowing.

B5

Flow HOT water for 5 minutes.

Flow HOT water for 5 minutes.

Flow HOT water for 5 minutes.

B6

After 5 minutes, wave your hand over top sensor (WAVE SENSOR), continue up to 5 times, pause 3 seconds between each wave (refer to step 26).

After 5 minutes, wave your hand over top sensor (WAVE SENSOR), continue up to 5 times, pause 3 seconds between each wave (refer to step 26).

After 5 minutes, wave your hand over top sensor (WAVE SENSOR), continue up to 5 times, pause 3 seconds between each wave (refer to step 26).

B8

Call Moen consumer service. Control box service kit **163713** is required. (1-800-BUY-MOEN, 1-800-289-6636).

Call Moen consumer service. Control box service kit **163713** is required. (1-800-BUY-MOEN, 1-800-289-6636).

Call Moen consumer service. Control box service kit **163713** is required. (1-800-BUY-MOEN, 1-800-289-6636).

Note: This equipment has been tested and found to comply with the limits for a Class B digital device, pursuant to part 15 of the FCC Rules. These limits are designed to provide reasonable protection against harmful interference in a residential installation. This equipment generates, uses and can radiate radio frequency energy and, if not installed and used in accordance with the instructions, may cause harmful interference to radio communications. However, there is no guarantee that interference will not occur in a particular installation. If this equipment does cause harmful interference to radio or television reception, which can be determined by turning the equipment off and on, the user is encouraged to try to correct the interference by one or more of the following measures:

- Reorient or relocate the receiving antenna.
- Increase the separation between the equipment and receiver.
- Connect the equipment into an outlet on a circuit different from that to which the receiver is connected.
- Consult the dealer or an experienced radio/TV technician for help.

Changes or modifications not expressly approved by Moen Incorporated could void the user's authority to operate the equipment.

Note: This equipment has been tested and found to comply with the limits for a Class B digital device, pursuant to part 15 of the FCC Rules. These limits are designed to provide reasonable protection against harmful interference in a residential installation. This equipment generates, uses and can radiate radio frequency energy and, if not installed and used in accordance with the instructions, may cause harmful interference to radio communications. However, there is no guarantee that interference will not occur in a particular installation. If this equipment does cause harmful interference to radio or television reception, which can be determined by turning the equipment off and on, the user is encouraged to try to correct the interference by one or more of the following measures:

- Reorient or relocate the receiving antenna.
- Increase the separation between the equipment and receiver.
- Connect the equipment into an outlet on a circuit different from that to which the receiver is connected.
- Consult the dealer or an experienced radio/TV technician for help.

Changes or modifications not expressly approved by Moen Incorporated could void the user's authority to operate the equipment.

Note: This equipment has been tested and found to comply with the limits for a Class B digital device, pursuant to part 15 of the FCC Rules. These limits are designed to provide reasonable protection against harmful interference in a residential installation. This equipment generates, uses and can radiate radio frequency energy and, if not installed and used in accordance with the instructions, may cause harmful interference to radio communications. However, there is no guarantee that interference will not occur in a particular installation. If this equipment does cause harmful interference to radio or television reception, which can be determined by turning the equipment off and on, the user is encouraged to try to correct the interference by one or more of the following measures:

- Reorient or relocate the receiving antenna.
- Increase the separation between the equipment and receiver.
- Connect the equipment into an outlet on a circuit different from that to which the receiver is connected.
- Consult the dealer or an experienced radio/TV technician for help.

Changes or modifications not expressly approved by Moen Incorporated could void the user's authority to operate the equipment.

MotionSense™ System Limited Warranty**1. Identity and Types of Warranty Holders**

i. "Original Consumer Purchaser" means the owner-of-record of a single-family residential owner-occupied dwelling in which the Product is initially installed (or, if installed by a builder/contractor/owner, the owner-of-record to whom the builder/contractor/owner first transfers the single-family dwelling), but only so long as such Purchaser owns the single-family dwelling where the Product was installed, and subject to the additional restrictions stated below.

ii. All others who do not fit within the definition of "Original Consumer Purchaser," but who have purchased the Product, are considered an "Original Commercial Purchaser," but only so long as such Purchaser owns the premises where the Product was installed, and subject to the additional restrictions stated below.

What is Covered by This Limited Warranty, and the Applicable Warranty Periods

Moen ("Seller") warrants that the MotionSense™ System ("the Product") will be free from defects in materials and manufacturing workmanship. Moen warrants that the faucet will be leak-free and drip-free under normal use, and that the Product's control box (which houses the hydraulic system) and finish will be free from defects in material and manufacturing workmanship for: (1) the lifetime of the Original Consumer Purchaser; or (2) five years from the date of purchase for the Original Commercial Purchaser (but only so long as the Original Consumer/Commercial Purchaser continues to own the dwelling or premises). The warranty on all other components of the Product, including but not limited to the electronics box, spout and lenses, runs for: (1) five years from the date of purchase for an Original Consumer Purchaser; or (2) one year from date of purchase for an Original Commercial Purchaser (but only so long as the Original Consumer/Commercial Purchaser continues to own the dwelling or premises). This Limited Warranty may not be transferred to subsequent owners of the dwelling or premises, or to any other person.

What This Limited Warranty Does Not Cover

This Limited Warranty covers only those workmanship and material non-conformities specified above, and does cover non-conformities or damages arising from any other cause, including without limitation, defects or damage due to the use of other than genuine Moen parts, due to installation error, product abuse, or product misuse or due to the use of cleaners containing abrasives, alcohol or other organic solvents.

Buyer's Sole And Exclusive Remedy Under This Limited Warranty

In the event of a non-conformity in workmanship or materials in one or more components of the Product, Seller's sole obligation is, at its sole option, to repair or replace any non-conforming component, or refund the Product's purchase price. This is the warranty holder's sole and exclusive remedy for the Product under this Limited Warranty. By way of example but not limitation, the following costs and expenses are not covered by this Limited Warranty: (i) labor costs for the removal, reinstallation, or refinishing of the Product, or non conforming part thereof (or of building materials which must be removed, reinstalled or refinished in order to repair or replace the non-conforming Product); (ii) shipping and freight expenses required to return Product to Seller. Repaired or replaced components are individually warranted only under the same terms and for the remaining balance of the Limited Warranty period applicable to that component(s) which is/are repaired or replaced.

DISCLAIMER OF WARRANTIES

THE FOREGOING LIMITED WARRANTY IS IN LIEU OF AND EXCLUDES ALL OTHER WARRANTIES NOT EXPRESSLY SET FORTH HEREIN, WHETHER EXPRESS OR IMPLIED, BY OPERATION OF LAW OR OTHERWISE, INCLUDING BUT NOT LIMITED TO ANY IMPLIED WARRANTIES OF MERCHANTABILITY OR FITNESS FOR A PARTICULAR PURPOSE. TO THE EXTENT THAT ANY IMPLIED WARRANTIES MAY NONETHELESS EXIST BY OPERATION OF LAW, ANY SUCH WARRANTIES ARE LIMITED TO THE DURATION PROVIDED BY THAT LAW. SOME STATES/PROVINCES DO NOT ALLOW LIMITATIONS ON HOW LONG AN IMPLIED WARRANTY LASTS, SO THE ABOVE LIMITATIONS MAY NOT APPLY TO YOU.

LIMITATION OF LIABILITY

SELLER'S SOLE LIABILITY UNDER THIS LIMITED WARRANTY SHALL BE REPLACEMENT OR REPAIR, OR REFUND OF THE PURCHASE PRICE AS SET FORTH ABOVE. IN NO EVENT, WILL SELLER BE LIABLE FOR INCIDENTAL, CONSEQUENTIAL, INDIRECT, SPECIAL, OR PUNITIVE DAMAGES INCLUDING, BUT NOT LIMITED TO, LABOR, REMOVAL, REINSTALLATION, REFINISHING, LOSS OF USE OF THE PRODUCT, LOSS OF PROFITS, LOSS OF REVENUE, LOST GOODWILL, CLAIMS OF EMOTIONAL DISTRESS, OR CLAIMS OF WARRANTY HOLDERS' CUSTOMERS, WHETHER BASED ON CONTRACT, WARRANTY, TORT (INCLUDING, BUT NOT LIMITED TO, STRICT LIABILITY OR NEGLIGENCE) OR OTHERWISE, EVEN IF ADVISED OF THE POSSIBILITY OF SUCH DAMAGES. SOME STATES DO NOT ALLOW THE EXCLUSION OR LIMITATION OF INCIDENTAL OR CONSEQUENTIAL DAMAGES, SO THE ABOVE LIMITATION OR EXCLUSION MAY NOT APPLY TO YOU. THIS LIMITED WARRANTY GIVES YOU SPECIFIC LEGAL RIGHTS AND YOU MAY ALSO HAVE OTHER RIGHTS WHICH VARY FROM STATE TO STATE, AND PROVINCE TO PROVINCE. EVEN IF THIS LIMITED WARRANTY IS DEEMED TO HAVE FAILED OF ITS ESSENTIAL PURPOSE, IN NO EVENT WILL SELLER'S ENTIRE LIABILITY EXCEED THE PURCHASE PRICE OF THE PRODUCT WARRANTED HEREUNDER, OR THE NON-CONFORMING PORTION THEREOF, WHICHEVER IS THE LESSER AMOUNT.

Warranty Claims

To initiate a claim, call Moen at 800-289-6636 (800-465-6130 in Canada; 01-800-718-4345 in Mexico), or write Moen at the address on the reverse side. Proof of purchase is required.

Garantía limitada del Sistema MotionSense™**1. Identidad y tipos de titulares de garantía**

i. "Consumidor Comprador Original" significa el propietario registrado de un inmueble residencial unifamiliar ocupado por su dueño en el que el Producto es instalado inicialmente (o, en el caso en que sea instalado por un constructor/contratista/propietario, propietario registrado al que dicho constructor/contratista/propietario transfiera por primera vez el inmueble unifamiliar), pero sólo mientras dicho Comprador sea propietario del inmueble unifamiliar en el que fue instalado el Producto, y sujeto a las restricciones adicionales establecidas a continuación.

ii. Toda otra persona que no se ajuste a la definición de "Consumidor Comprador Original," pero que haya adquirido el Producto será considerada "Comprador Comercial Original" pero sólo en tanto dicho Comprador sea propietario de las instalaciones en las que fue instalado el Producto, y sujeto a las restricciones adicionales establecidas a continuación.

Qué cubre esta Garantía Limitada, y periodos de garantía aplicables

Moen ("el Vendedor") garantiza que el Sistema MotionSense™ ("el Producto") está libre de defectos de materiales y fabricación. Moen garantiza que la mezcladora estará libre de fugas o goteos en condiciones de uso normal, y que la caja de control del Producto (que aloja el sistema hidráulico) y el acabado estarán libres de defectos de materiales y fabricación durante: (1) la duración de la vida del Consumidor Comprador Original; o (2) cinco años desde la fecha de compra para el Comprador Comercial Original (siempre y cuando el Consumidor/Comprador Comercial Original continúe siendo propietario del inmueble o las instalaciones). La garantía sobre todos los otros componentes del Producto, incluyendo, en forma enunciativa y no limitativa, la caja de electrónica, el surtidor y las lentes, estará vigente durante: (1) cinco años desde la fecha de compra para el Consumidor Comprador Original; o (2) un año desde la fecha de compra para el Comprador Comercial Original (siempre y cuando el Consumidor/Comprador Comercial Original continúe siendo propietario del inmueble o las instalaciones). Esta Garantía Limitada no puede ser transferida a propietarios subsiguientes del inmueble o de las instalaciones, o a ninguna otra persona.

Qué no cubre esta Garantía Limitada

Esta Garantía Limitada cubre solamente los defectos de materiales y fabricación especificados más arriba, y no cubre defectos o daños que surjan de cualquier otra causa, incluyendo, en forma enunciativa y no limitativa, defectos o daños debidos al uso de piezas que no sean piezas Moen genuinas, errores de instalación, abuso o uso incorrecto del producto, o el uso de limpiadores que contengan abrasivos, alcohol u otros solventes orgánicos.

Recurso único y exclusivo del comprador bajo esta Garantía Limitada

En el caso de un defecto de fabricación o materiales en uno o más componentes del Producto, la única obligación del Vendedor, a su elección, es reparar o reemplazar cualquier componente defectuoso o reembolsar el precio de compra del Producto. Esto constituye el único y exclusivo recurso del comprador para el Producto bajo esta Garantía Limitada. Como ejemplo en forma enunciativa y no limitativa, los siguientes costos y expensas no están cubiertos por esta Garantía Limitada: (i) costos de mano de obra para retirar, reinstalar o re-acabado del Producto o de la pieza defectuosa del mismo (o de los materiales de construcción que deban ser removidos, reinstalados o re-acabados para reparar o reemplazar el Producto defectuoso); (ii) gastos de envío requeridos para devolver el Producto al Vendedor. Los componentes reparados o reemplazados son garantizados individualmente sólo bajo los mismos términos y por el tiempo restante del periodo de la Garantía Limitada aplicable a dicho(s) componente(s) reparado(s) o reemplazado(s).

RESTRICCIÓN DE GARANTÍAS

LA ANTERIOR GARANTÍA LIMITADA SUSTITUYE Y EXCLUYE CUALQUIER OTRA GARANTÍA NO EXPRESAMENTE EXPUESTA AQUÍ, EXPRESA O IMPLÍCITAMENTE, CONFORME A DERECHO O DE OTRO MODO, INCLUSIVE PERO NO LIMITADA A CUALQUIER GARANTÍA IMPLÍCITA DE COMERCIABILIDAD O APTITUD PARA UN PROPÓSITO EN PARTICULAR. EN LA MEDIDA EN QUE CUALQUIER GARANTÍA IMPLÍCITA PUEDA SIN EMBARGO EXISTIR CONFORME A DERECHO, CUALQUIER GARANTÍA DE ESE TIPO ESTARÁ LIMITADA A LA DURACIÓN PREVISTA POR DICHA LEY. ALGUNOS ESTADOS/PROVINCIAS NO PERMITEN LIMITACIONES RESPECTO DE LA DURACIÓN DE UNA GARANTÍA IMPLÍCITA, DE MODO QUE LAS LIMITACIONES QUE PRECEDEN PUEDEN NO SER APLICABLES EN SU CASO.

LIMITACIÓN DE RESPONSABILIDAD

LA ÚNICA RESPONSABILIDAD DEL VENDEDOR BAJO ESTA GARANTÍA LIMITADA SERÁ REEMPLAZAR / REPARAR O REEMBOLSAR EL PRECIO DE COMPRA COMO SE ESTABLECE ARRIBA. EL VENDEDOR NO SERÁ RESPONSABLE EN NINGÚN CASO POR DAÑOS INCIDENTALES, EMERGENTES, INDIRECTOS, ESPECIALES, O PUNITIVOS, INCLUYENDO, EN FORMA ENUNCIATIVA Y NO LIMITATIVA, MANO DE OBRA, REMOCIÓN, REINSTALACIÓN, RE-ACABADO, PÉRDIDA DE USO DEL PRODUCTO, PÉRDIDA DE BENEFICIOS, PÉRDIDA DE GANANCIA, PÉRDIDA DE PLUSVALÍA, RECLAMOS DE SUFRIMIENTO EMOCIONAL, O RECLAMOS DE CLIENTES DEL TITULAR DE LA GARANTÍA, PERJUICIOS (INCLUYENDO, EN FORMA ENUNCIATIVA Y NO LIMITATIVA, RESPONSABILIDAD O NEGLIGENCIA ESTRICTAS) U OTROS, AUN EN CASO DE HABER SIDO ADVERTIDOS DE LA POSIBILIDAD DE DICHOS DAÑOS. ALGUNOS ESTADOS NO PERMITEN LA EXCLUSIÓN O LIMITACIÓN DE DAÑOS INCIDENTALES O EMERGENTES, DE MODO QUE LA LIMITACIÓN O EXCLUSIÓN QUE PRECEDE PUEDE NO SER APLICABLE EN SU CASO. ESTA GARANTÍA LIMITADA LE OTORGA DERECHOS LEGALES ESPECÍFICOS Y PUEDE QUE TENGA OTROS DERECHOS QUE VARIAN DE UN ESTADO A OTRO Y DE UNA PROVINCIA A OTRA. AUN EN EL CASO EN QUE SE CONSIDERE QUE ESTA GARANTÍA LIMITADA NO CUMPLE CON SU PROPÓSITO ESENCIAL, EN NINGÚN CASO LA RESPONSABILIDAD COMPLETA DEL VENDEDOR EXCEDERÁ EL PRECIO DE VENTA DEL PRODUCTO GARANTIZADO EN LA PRESENTE, O LA PIEZA DEFECTUOSA DEL MISMO, CUALQUIERA SEA EL MONTO MENOR.

Reclamos de Garantía

Para iniciar un reclamo, llame a Moen al 800-289-6636 (800-465-6130 en Canadá; 01-800-718-4345 en México), o escriba a Moen a la dirección que figura al dorso. Se requiere comprobante de compra.

Garantie limitée du système MotionSenseMC

1. Identité et types des titulaires visés par la garantie

i. « L'Acheteur consommateur initial » signifie le propriétaire inscrit d'une habitation unifamiliale occupée par le propriétaire et où le Produit est installé à l'origine (ou, si installé par un entrepreneur/constructeur/propriétaire, le propriétaire inscrit à qui le constructeur/entrepreneur propriétaire transfère d'abord l'habitation unifamiliale), mais seulement pour la durée pendant laquelle un tel acheteur possède l'habitation unifamiliale où le produit est installé, et conformément aux restrictions additionnelles indiquées ci-dessous.

ii. Toute autre personne non conforme à ladite définition d'un « Acheteur consommateur initial », et ayant acheté le Produit, est considérée comme un « Acheteur commercial initial », mais seulement pendant la période où l'Acheteur est propriétaire de l'habitation où le Produit a été installé, et conformément aux restrictions additionnelles indiquées ci-dessous.

Ce qui est couvert par cette garantie limitée et les périodes de garantie applicables

Moen (le « Vendeur ») garantit que le système MotionSenseMC ne présentera aucun défaut de matériaux ni de fabrication. Moen garantit que le robinet sera libre de toute fuite ou d'égouttement pendant son usage normal et que le boîtier de contrôle du Produit (qui contient le système hydraulique) et le fini ne présenteront aucun défaut de matériel et de main-d'œuvre en usine pour la durée indiquée ci-dessous : (1) Pendant toute la durée de vie de l'Acheteur consommateur initial; ou (2) pendant cinq (5) ans à compter de la date d'achat dans le cas d'un Acheteur commercial initial (mais seulement tant que l'Acheteur consommateur/commercial initial continuera d'être propriétaire de l'habitation ou des lieux). La garantie pour toutes les autres pièces du Produit, y compris, mais sans s'y limiter le boîtier électronique, le bec et les lentilles, sera d'une durée de : (1) cinq (5) ans à compter de la date d'achat d'un Acheteur consommateur initial ou de deux (2) ans à compter de la date d'achat dans le cas d'un Acheteur commercial initial (mais seulement tant que l'Acheteur consommateur/commercial initial est propriétaire de l'habitation ou des lieux). Cette garantie limitée ne peut pas être transférée à des propriétaires ultérieurs de l'habitation ou des lieux ni à toute autre personne.

Ce que cette garantie ne couvre pas

Cette garantie limitée ne couvre que les défauts de conformité de fabrication et de matériaux indiqués ci-dessus, et ne couvre pas les problèmes de conformité ni les dommages pouvant découler de toute autre cause, y compris, mais sans s'y limiter, les défauts ou les dommages causés par l'utilisation de pièces autres que les pièces d'origine Moen, l'erreur d'installation, l'usage abusif ou incorrect du Produit ou tout dommage causé par l'utilisation de produits nettoyants contenant des agents abrasifs, de l'alcool ou tout autre solvant organique.

Recours unique et exclusif de l'Acheteur en vertu de cette garantie limitée

En cas de défauts de conformité liés à la fabrication ou aux matériaux trouvés dans l'un ou plusieurs des composants du Produit, l'unique obligation du Vendeur consiste, à sa seule discrétion, à réparer ou à remplacer tout composant non conforme ou à rembourser à l'Acheteur le prix d'achat du Produit. Il s'agit de l'unique recours exclusif du titulaire de la garantie du Produit en vertu de cette garantie limitée. Par exemple, sans s'y limiter, les coûts et frais suivants ne sont pas couverts par cette garantie limitée : (i) les coûts de main-d'œuvre liés au retrait, à la réinstallation ou à la refinition du Produit ou de l'un de ses composants (ou celui des matériaux de construction ayant dû être enlevés, réinstallés ou refinis afin d'effectuer la réparation ou de remplacer le Produit non conforme); (ii) les frais d'expédition ou de transport requis pour retourner le Produit au Vendeur.

Les composants remplacés ou réparés ne sont individuellement garantis qu'en vertu des mêmes modalités et pour la durée restante de la période de garantie limitée, applicable à ce ou ces composants qui sont réparés ou remplacés.

STIPULATION D'EXONÉRATION DE GARANTIES

LA GARANTIE LIMITÉE DE LA PRÉSENTE REMPLACE ET EXCLUT TOUTE AUTRE GARANTIE NON INDIQUÉE EXPRESSÉMENT AUX PRÉSENTES, PEU IMPORTE QU'ELLE SOIT EXPLICITE OU IMPLICITE, PAR EFFET DE LA LOI OU AUTREMENT, Y COMPRIS, MAIS SANS S'Y LIMITER, TOUTE GARANTIE IMPLICITE DE QUALITÉ MARCHANDE OU D'ADÉQUATION À UN USAGE PARTICULIER. DANS LA MESURE OÙ TOUTE GARANTIE IMPLICITE PEUT TOUT DE MÊME EXISTER EN VERTU DE LA LOI, UNE TELLE GARANTIE EST LIMITÉE À LA DURÉE DÉTERMINÉE PAR CETTE LOI. CERTAINS ÉTATS OU PROVINCES N'AUTORISENT PAS LA LIMITATION DE DURÉE DE GARANTIES IMPLICITES, ALORS LES LIMITATIONS PRÉCITÉES PEUVENT NE PAS S'APPLIQUER À VOTRE CAS.

LIMITÉ DE RESPONSABILITÉ

LA SEULE RESPONSABILITÉ DU VENDEUR, EN VERTU DE CETTE GARANTIE, SE LIMITE AU REMPLACEMENT OU À LA RÉPARATION DU PRODUIT, OU AU REMBOURSEMENT DE SON PRIX D'ACHAT, COMME INDIQUÉ CI-DESSUS. EN AUCUN CAS, LE VENDEUR NE POURRA ÊTRE TENU RESPONSABLE DE DOMMAGES ACCIDENTELS, INDIRECTS, CONSÉCUTIFS, NI DE DOMMAGES-INTÉRÊTS SPÉCIAUX OU PUNITIFS, Y COMPRIS, MAIS SANS S'Y LIMITER, LES DOMMAGES LIÉS À LA FABRICATION, AU RETRAIT, À LA RÉINSTALLATION, À LA REFINITION, À LA PERTE D'UTILISATION DU PRODUIT, OU À UNE PERTE DE PROFIT, À LA PERTE D'UN REVENU, À LA PERTE D'UNE SURVALEUR, OU DE RÉCLAMATIONS POUR TROUBLES ÉMOTIONNELS SUBIS PAR LE TITULAIRE DE LA GARANTIE, OU PAR DES CLIENTS DE CELUI-CI, PEU IMPORTE QUE DE TELLES RÉCLAMATIONS S'APPUIENT SUR UN CONTRAT, UNE GARANTIE OU UN DÉLIT CIVIL (Y COMPRIS, MAIS SANS S'Y LIMITER, LA RESPONSABILITÉ STRICTE OU LA NÉGLIGENCE) OU AUTRE, MÊME SI AVISÉ DE LA POSSIBILITÉ DE TELS DOMMAGES. CERTAINS ÉTATS OU PROVINCES PEUVENT NE PAS AUTORISER L'EXCLUSION OU LA LIMITATION DES DOMMAGES ACCESSOIRES OU CONSÉCUTIFS. LES LIMITES OU LES EXCLUSIONS PRÉCITÉES PEUVENT DONC NE PAS S'APPLIQUER À VOTRE CAS. CETTE GARANTIE LIMITÉE VOUS DONNE DES DROITS JURIDIQUES PARTICULIERS ET VOUS POUVEZ AVOIR D'AUTRES DROITS QUI PEUVENT VARIER ENTRE LES ÉTATS OU LES PROVINCES. MÊME ADVENANT LE CAS OÙ CETTE GARANTIE LIMITÉE SERAIT RÉPUTÉE AVOIR CONTREVENU À SON OBJECTIF PRINCIPAL, EN AUCUN CAS L'OBLIGATION DU VENDEUR NE DÉPASSERA LE PRIX D'ACHAT DU PRODUIT GARANTI EN VERTU DES PRÉSENTES OU DU COMPOSANT NON CONFORME DE CELUI-CI, SELON CE QUI REPRÉSENTE LA SOMME LA MOINS ÉLEVÉE ENTRE CES DEUX ÉVENTUALITÉS. ITS ESSENTIAL PURPOSE, IN NO EVENT WILL SELLER'S ENTIRE LIABILITY EXCEED THE PURCHASE PRICE OF THE PRODUCT WARRANTED HEREUNDER, OR THE NON-CONFORMING PORTION THEREOF, WHICHEVER IS THE LESSER AMOUNT.

Réclamations au titre de la garantie

Pour faire une réclamation, veuillez appeler Moen au 1-800-465-6130 (1-800-289-6636 aux É.-U.; 01-800-718-4345 au Mexique) ou écrivez à Moen à l'adresse indiquée au verso. Une preuve d'achat sera requise.



Buy it for looks. Buy it for life.®

Moen Incorporated
25300 Al Moen Drive
North Olmsted, Ohio 44070-8022 U.S.A.

Moen de Mexico, S.A. de C.V.
Carretera Saltillo-Monterrey KM 14.7
Ramos Arizpe, Coahuila
Mexico 25900

Moen Inc.
2816 Bristol Circle
Oakville, Ontario L6H 5S7

INS10188 - 4/13

©2013 Moen Incorporated