

10075650

FF525HBNCMES

52" Dual-Mount Ceiling Fan

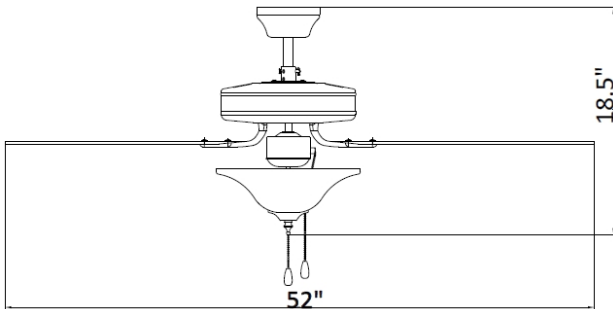

FEATURES	52" Dual-Mount Ceiling Fan
Mounting Type	Dual-Mount
Fan Span	52"
No. of Blades	5
Product Use	Residential
Body Color	Brushed Nickel
Blade Material	Plywood
Blade Color(s)	Maple and Cherry
Blade Pitch	12"
Rotation	Reversible
Downrod	4"
No. of Speeds	3
Motor Size (MM)	155*10 DC
Motor Diameter	6"
AMPS (HI speed)	0.41
Watts (HI speed)	24W
Airflow (Cu. Ft. Per Minute)	4200
Airflow Efficiency (CFM/watt)	224
Control	Chain
Light Kit	Alabaster Glass
Lamp Source	LED, E26 med, 9W, 3000K, 15,000 hrs
Bulbs Included	Yes

FF525HBNCMES

- 52" dual-mount ceiling fan
- 3-speed reversible motor
- Alabaster glass light kit
- Two 9W medium base LED bulbs included
- 3000 Kelvin
- 15,000 average hour life
- Five blades



SAMPLE SPECIFICATION:

Ceiling fan shall be 10075650 52" five blade in Brushed Nickel finish, Maple and Cherry blades