

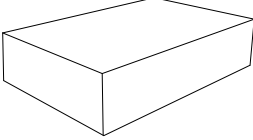









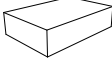





ASSEMBLY INSTRUCTIONS

INSET SINK BASE CABINET | SB33-36

PACKAGING	ITEM	ITEM CODE	QTY	PACKAGING	ITEM	DESCRIPTION	QTY
		TOOLS REQUIRED: 1. PHILLIPS SCREWDRIVER 2. DRILL		 HARDWARE BOX		HINGES	4
		A-1	1			CAM LOCK	10
		A-2	1			16MM SCREW	32
		F B	1			CAM LOCK SCREW	10
		C	1			30MM SCREW	2
		D	1			SHELF HOLDER	4
		E	1				
		H	2				

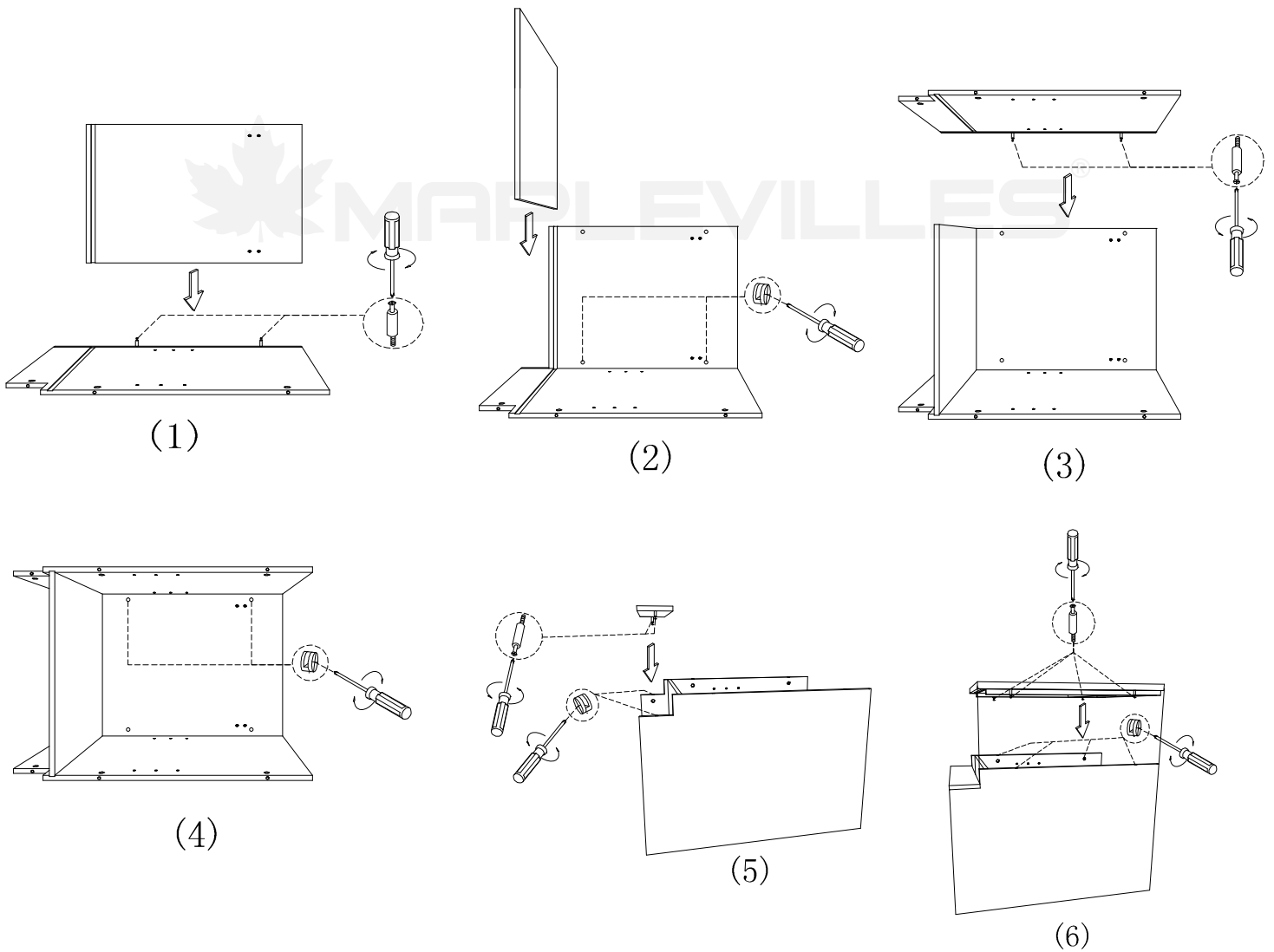

ASSEMBLY INSTRUCTIONS

INSET SINK BASE CABINET | SB33-36

