

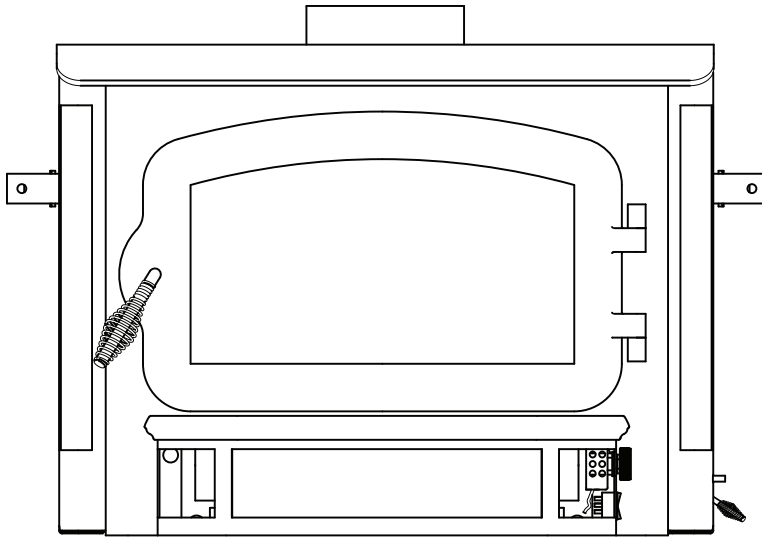

Savannah Wood Insert

For Residential Installation



Owners Manual
Model: SSI30

6" (152 mm) Flue Required

SAFETY NOTICE: READ THIS ENTIRE MANUAL BEFORE YOU INSTALL AND USE YOUR APPLIANCE. IF NOT PROPERLY INSTALLED, A HOUSE FIRE MAY RESULT. TO REDUCE THE RISK OF FIRE, FOLLOW THE INSTALLATION INSTRUCTIONS. FAILURE TO FOLLOW INSTRUCTIONS MAY RESULT IN PROPERTY DAMAGE, BODILY INJURY, OR EVEN DEATH. CONTACT LOCAL BUILDING, FIRE OFFICIALS OR AUTHORITIES HAVING JURISDICTION ABOUT PERMITS, RESTRICTIONS AND INSTALLATION INSPECTION REQUIREMENTS IN YOUR AREA.

THESE UNITS ARE MOBILE HOME APPROVED FOR U.S. AND CANADA

NATIONAL FIREPLACE INSTITUTE
NFI
CERTIFIED
www.nficertified.org

We recommend that our woodburning hearth products be installed and serviced by professionals who are certified in the U.S. by the National Fireplace Institute® (NFI) as NFI Woodburning Specialists or who are certified in Canada by Wood Energy Technical Training (WETT).

Wood Energy Technical Training
www.wettinc.ca



Congratulations on your choice of a MHSC Savannah. With this purchase, you made a commitment to make the hearth a place of warmth, beauty and comfort in your home. At MHSC, we share that joy and appreciation of the hearth, and we show it in all our cast iron inserts and fireplaces.

As you become acquainted with your new insert, you will find the aesthetic appeal of cast iron is matched only by its superb capacity to absorb and radiate heat.

Also, MHSC products are among the cleanest burning wood inserts and fireplaces available today. As an owner of a MHSC insert, you are making a strong statement for pollution-free energy. But clean burning depends on both the manufacturer and the operator. Please read this manual carefully to understand how to properly operate your insert.

At MHSC, we are equally committed to your satisfaction as a customer and that is why we maintain an exclusive network of the finest dealers in the industry. Chosen for their expertise and dedication to customer service, our dealers are factory-trained and know each MHSC product in detail. Feel free to contact your Authorized MHSC Dealer anytime you have a question about your insert or its performance.

We have built your insert with the utmost care. With normal use and proper care, it will provide you with many years of service.

This manual contains valuable instructions on the installation and operation of your MHSC insert. You will also find useful information on assembly and maintenance procedures. We urge you to read the manual thoroughly and to keep it as a reference.

Sincerely,

All of us at MHSC

This manual describes the installation, operation, and maintenance of the MHSC Savannah wood burning heater. This heater meets the U.S. Environmental Protection Agency's emission limits for wood heaters sold on or after July 1, 1990. Under specific test conditions this heater has been shown to deliver heat at rates ranging from 11,000 to 30,600 Btu/hr.

The insert has been tested and is listed by OMNI - Test Laboratories, Inc. of Portland, Oregon. The test standards are ANSI/UL-1482 for the United States, and ULC S628 for Canada. The Savannah is listed for burning wood only. Do not burn other fuels. The Savannah is approved for use in manufactured (mobile) homes in the United States and Canada.

Installation or service of this woodburning insert should only be completed by a qualified installer, preferably NFI or WETT (Canada) certified.

Please read this entire manual before you install and use your new insert. Failure to follow instructions may result in property damage, bodily injury, or even death.

NOTICE

SAVE THESE INSTRUCTIONS FOR FUTURE REFERENCE

INSTALLER

Please leave these instructions with the appliance.

OWNER

Please retain these instructions for future reference.

IMPORTANT

Read these instructions carefully before installing or trying to operating this woodburning appliance.

TABLE OF CONTENTS

Questions 3

Safety Information 4

Insert Dimensions and Specifications..... 6

Surround Options 6

Pre-installation instructions..... 7

Clearances 8

Floor Protection 8

Chimney Clearances 9

Installation 11

Operation..... 16

Maintenance..... 18

Replacement parts 20

FAQs..... 22

Warranty 24

ACCESSORIES

Gold Door Trim	SSW30GDTK
Nickel Door Trim	SSW30NDTK
Adjustable Raised Hearth Kit	SSI30AH
Offset Flue Kit	OFC3 & OFC6

! WARNING



HOT GLASS WILL CAUSE BURNS.

DO NOT TOUCH GLASS UNTIL COOLED.

NEVER ALLOW CHILDREN TO TOUCH GLASS.

WARNING

PROPOSITION 65 WARNING

FUELS USED IN GAS, WOODBURNING OR OIL FIRED APPLIANCES, AND THE PRODUCTS OF COMBUSTION OF SUCH FUELS, CONTAIN CHEMICALS KNOWN TO THE STATE OF CALIFORNIA TO CAUSE CANCER, BIRTH DEFECTS AND OTHER REPRODUCTIVE HARM. CALIFORNIA HEALTH AND SAFETY CODE SEC. 25249.6

NEED TO ASK QUESTIONS? REQUIRE PARTS INFORMATION?

First, contact the MHSC Dealer from whom you purchased your insert, for parts and service. Have the following information ready:

- Date of purchase
- Serial number (from the back of your insert)
- Model number (from the back of your insert)
- Dealer name and phone

If you still need assistance, contact MHSC technical support (below).

WONDERING ABOUT THE WARRANTY?

See the last page of this manual for general warranty information. For additional information, contact your MHSC dealer or MHSC Parts and warranty.

MHSC
Technical Service, Parts & Warranty
Phone: 877-406-9180
Fax: 877-406-5647

NOTE: Before installing your appliance, be sure to write down the model and serial numbers and keep them in a safe place. Once installed, this information is no longer visible on your appliance.

Please Read This Manual Before Installing and Using Fireplace

IMPORTANT: Read all instructions and warnings carefully before starting installation. Failure to follow these instructions may result in a possible fire hazard and will void the warranty.

SAFETY NOTICE: IF YOUR INSERT IS NOT PROPERLY INSTALLED, OPERATED AND MAINTAINED, A HOUSE FIRE MAY RESULT. FOR SAFETY, FOLLOW ALL INSTALLATION, OPERATION AND MAINTENANCE DIRECTIONS. CONTACT LOCAL BUILDING OFFICIALS ABOUT RESTRICTIONS AND INSTALLATION INSPECTION REQUIREMENTS IN YOUR AREA.

PRECAUTIONS

MHSC inserts and component parts have been tested to operate safely when installed in accordance with instructions provided in this manual. Carefully read and understand all instructions before beginning installation.

If you notice any damage to insert or component parts, immediately report damage to your MHSC dealer.

Only use MHSC components or the warranty will be voided and a fire hazard may be created.

MHSC warranty will be voided by and MHSC disclaims any responsibility for the following actions:

- **Installation of any damaged insert or chimney component;**
- **Modification of insert, chimney assembly or any component parts thereof;** (except for chase flashings as detailed in MHSC Chimney Top installation instructions).
- **Installation other than as instructed by MHSC; or**
- **Installation and/or use of any component part not manufactured or approved by MHSC in combination or assembly with a MHSC insert system, notwithstanding any independent testing laboratory or other third party approval of such component parts or accessory.**

Any such action may possibly cause a fire hazard.

Consult local building codes to ensure that you are in compliance **before** installing the insert.

This insert and chimney system must be vented outdoors.

Do not obstruct or modify air inlets/outlets in any manner.

Burn only solid wood fuel.

The insert is intended for operation only with the door fully closed.

Do not install any products not specified for use with this insert.

This insert is HOT WHILE IN OPERATION! KEEP CHILDREN, CLOTHING AND FURNITURE AWAY. CONTACT MAY CAUSE SKIN BURNS.

DO NOT OVERFIRE THIS HEATER. Overfiring can result in permanent damage to the insert. If an exterior part of the insert or the chimney connector glows, you are overfiring.

WARNING: OPERATE ONLY WITH DOORS FULLY CLOSED. IF DOORS ARE LEFT PARTLY OPEN, GAS AND FLAME MAY BE DRAWN OUT OF THE INSERT OPENING, CREATING RISKS OF BOTH FIRE AND SMOKE.

BEFORE INSTALLATION OF YOUR APPLIANCE

1. Check with the building inspector's office for compliance with local codes; a permit may be required.
2. This appliance requires a masonry or prefabricated chimney listed to ULC S629 (Canada) and UL 103HT (U.S.) sized correctly.
3. A 6" (152 mm) diameter flue is required for proper performance.
4. Always connect this unit to a chimney and **NEVER VENT TO ANOTHER ROOM OR INSIDE A BUILDING.**
5. **DO NOT** connect this unit to any duct work to which another appliance is connected such as a furnace.
6. **DO NOT** connect this unit to a chimney flue serving another appliance.
7. The connector pipe and chimney should be inspected periodically and cleaned if necessary.
8. Remember the clearance distances when you place furniture or other objects within the area. **DO NOT** store wood, flammable liquids or other combustible materials too close to the unit. **Refer to certification label on back of your unit for required clearances.**
9. Contact your local municipal or provincial fire authority for information on how to handle a chimney fire. Have a clearly understood plan to handle a chimney fire. In the event of a chimney fire, turn air control to closed position and **CALL THE FIRE DEPARTMENT.**
10. **DO NOT** tamper with combustion air control beyond normal adjustment.
11. If installing in a mobile home:
 - a. Use mobile home kit.
 - b. **WARNING: DO NOT INSTALL IN SLEEPING ROOM.**
 - c. **THE STRUCTURAL INTEGRITY OF THE MOBILE HOME FLOOR, WALLS AND CEILING/ROOF MUST BE MAINTAINED.**

WHY THE CORRECT FLUE SIZE IS IMPORTANT — 6" (152 mm)

Draft is the force, which moves air from the appliance up through the chimney. The amount of draft in your chimney depends on the length of the chimney, local geography, nearby obstructions, and other factors. Too much draft may cause excessive temperatures in the appliance. An uncontrolled burn, a glowing red part or chimney connector indicates excessive draft. Inadequate draft may cause back puffing into the room and “plugging” of the chimney and/or cause the appliance to leak smoke into the room through appliance and chimney connector joints.

Today’s solid fuel appliances are much more efficient than in the past. The units are designed to give you controlled combustion, as well as maximum heat transfer, using less fuel to do so. The design of your new appliance is such that the exhaust “smoke” is now at lower temperatures than in the past, therefore requiring proper chimney size to give adequate draft. If your chimney is too large, the heating appliance will have a difficult time to raise the “chimney flue” temperature to give adequate draft, therefore causing a smoke back up, poor burn, or both.

Should you experience such a problem call in a local chimney expert.

With the door closed, the rate of burning is regulated by the amount of air allowed to enter the unit through the air control. With experience you will be able to set the control for heat and burning time desired.

Once the required chimney draft is obtained, operate only with doors closed and open slowly when re-fueling. (This will reduce or eliminate smoke from entering the room.)

Attempts to achieve higher output rates that exceed heater design specifications can result in permanent damage to the heater. The recommended wood load is level with the top of the firebricks. Overloading may prevent sufficient air entering the heater to properly fuel the fire.

IMPORTANT: For optimum heater performance at “low” burn rate, operate the fan at low speed.

An outside air kit is available from your MHSC dealer.

Standard Blower: 110v 130 CFM

- **OPERATE THIS HEATER ONLY WITH THE DOOR CLOSED.**
- **DO NOT BURN GARBAGE OR FLAMMABLE FLUIDS.**
- **DO NOT USE CHEMICALS OR FLUIDS TO START THE FIRE.**
- **USE ONLY AUTHORIZED REPLACEMENT PARTS FROM YOUR MHSC DEALER. DO NOT INSTALL ANY OTHER COMPONENTS.**

AVOID DAMAGING THE GLASS DOOR PANEL

Do not abuse the glass by slamming the door or striking the glass with a log. Never operate your insert if it has damaged or broken glass. If you need to replace the glass, use only replacement glass provided by your MHSC dealer.

MATERIALS NEEDED FOR INSTALLATION:

- Adjustable wrench
- Flat & Phillips screwdriver
- Drill
- Tape measure
- Safety gloves
- Eye protection
- Appropriate venting components
- Furnace cement

INSERT DIMENSIONS

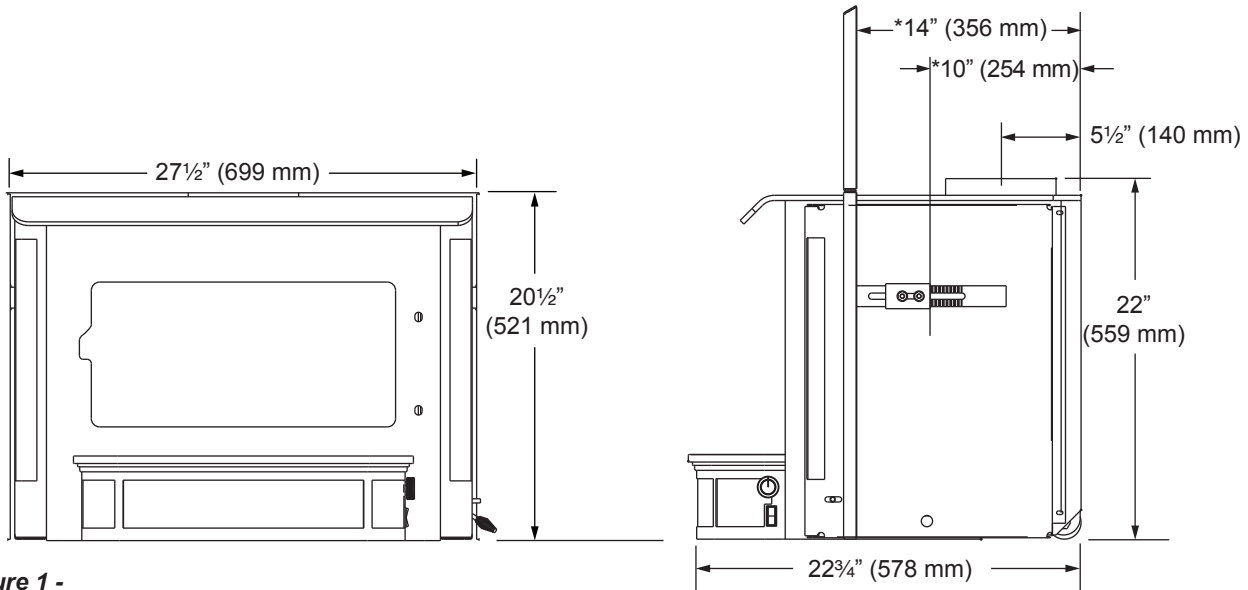

**Figure 1 -
Insert Dimensions**

* Surround Adjustment

Log Length	20" (508 mm)
Maximum burn time ²	10 hours
Average area heated (sq.ft) ²	2,200 sq. ft.
Range of heat output ³	11,000-30,600
Maximum heat output ¹	55,400
EPA emissions rating (g/h, non-catalytic)	3.5 gph
Weight	360 lbs
Loading	Front
Air Control	Manual

1. Maximum burn times and heat outputs are based on laboratory testing using full loads of seasoned hardwoods, and may vary in individual use depending on how the insert is operated, type and moisture content of fuel, and other factors. Maximum burn times are achieved under different operating conditions than are maximum heat outputs.
2. These values are based on operation in building code-conforming homes under typical winter climate conditions in the U.S. If your home is of nonstandard construction (e.g. unusually well-insulated, not insulated, built underground, or if you live in a more severe and more temperate climate), these figures may not apply. Since so many variables affect performance, consult your MHSC Authorized Dealer to determine realistic expectations for your home.
3. Under specific conditions used during EPA emissions testing.

SURROUND OPTIONS

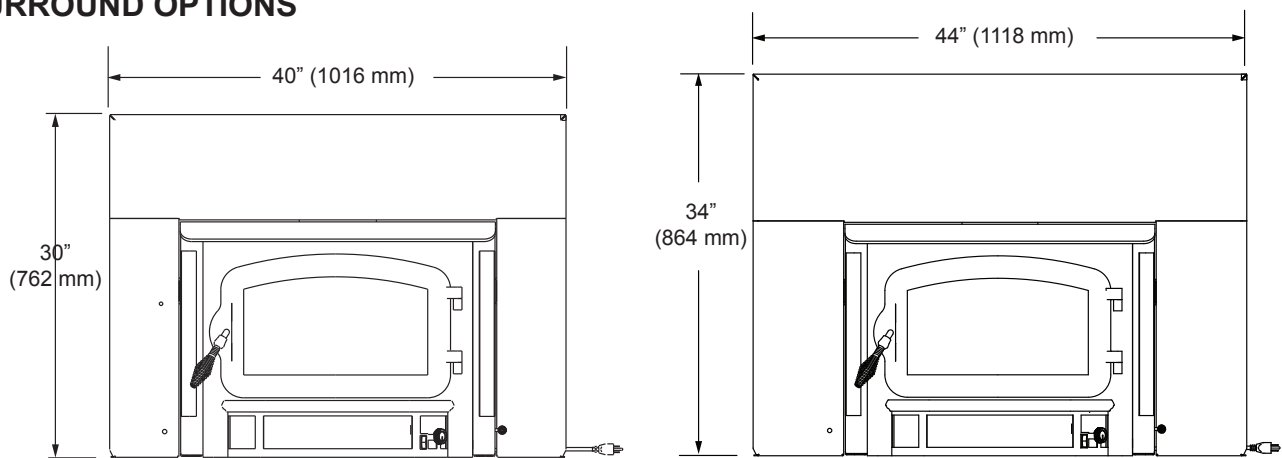

SSI30S40

SSI3044

ST1064

**Figure 2 -
Surround Options**

CAUTION

AFTER READING THESE INSTRUCTIONS, IF YOU HAVE ANY DOUBT ABOUT YOUR ABILITY TO COMPLETE YOUR INSTALLATION IN A PROFESSIONAL MANNER, YOU SHOULD OBTAIN THE SERVICES OF AN INSTALLER VERSED IN ALL ASPECTS OF CORRECT AND SAFE INSTALLATION. DO NOT USE TEMPORARY, MAKESHIFT COMPROMISES DURING INSTALLATION.

CAUTION

THIS HEATER IS EXTREMELY HOT WHILE IN OPERATION. SERIOUS BURNS CAN RESULT FROM CONTACT. KEEP CHILDREN, PETS, CLOTHING AND FURNITURE AWAY

DANGER

RISK OF ELECTRIC SHOCK. DISCONNECT POWER BEFORE SERVICING UNIT.

PLANNING YOUR INSTALLATION

1. Check with local building official for local code requirements.
2. The fireplace must not be altered for the purpose of accommodating the installation of this insert, except for removal of any of the following: flue damper, smoke shelf or baffle, ember catches, fire grate, viewing screen/curtain and/or doors.

Do not remove the metal warning label attached to the back of your insert.

3. Have your chimney and fireplace cleaned and inspected for serviceability before installing appliance. A professional chimney sweep can provide this service. They can also offer advice or install chimney liners and your insert.
 - a. Masonry fireplaces and chimney must be inspected for cracks, loose bricks or mortar. The chimney and fireplace must be cleaned before installing insert. Dirty chimneys can affect performance and cause fires.
 - b. Factory built fireplaces should be inspected for cracks, leaky joints, corrosion, warping, and any sign of structural or mechanical weakness. Correct any faults before installing insert. Check clearances of chimney to combustible surface as you inspect joints.

4. Plan your chimney connection system that makes the most sense for your particular situation. Make a list of the component you will need. There are two basic categories of fireplaces—manufactured and masonry. Chimneys can be steel or masonry. Liners are available to size the chimney to the insert and provide best performance and safety.

The actual connection from the unit to the chimney is made with adapters. One end will fit the 6” round flue collar and the other end will fit the chimney liner. Offset adapters are used in low clearance cases where the flue of the fireplace is recessed quite a bit, or the back of the fireplace is tapered to a smaller dimension than the insert.

- Use the dimensions guide on *Page 6* to help you understand if you will need an offset adapter.
5. Here are a few chimneys and connection types to give you an overview:

NOTE: Flue size is important! The cross sectional area of the chimney should not be larger than 3 times the cross sectional area of the insert.

- a. Masonry chimney with sealed throat and partial liner extended above the fireplace damper—This is not a recommended system. It requires the insert be removed to clean the chimney. The mass and overall size of many masonry chimneys can cause start up problems and creosote that can lead to chimney fires. Be sure to check the size of the flue.
 - b. Fully lined masonry chimney—This uses a flexible or ridge liner that is directly connected to the insert using a flexible, rigid or offset adapter. A good installation provides good performance and allows you to clean the chimney without removing the insert, in many cases.
 - c. Factory built chimney with full liner—Directly connected to the insert using flexible, rigid or offset adapters.
6. Review mantel, hearth and clearance to combustibles information on *Page 8*. Add to your list any protective shielding, hearth or surround components you will need to complete the installation.
 7. Order all the installation components from your dealer. Once you have them, you are ready to begin.

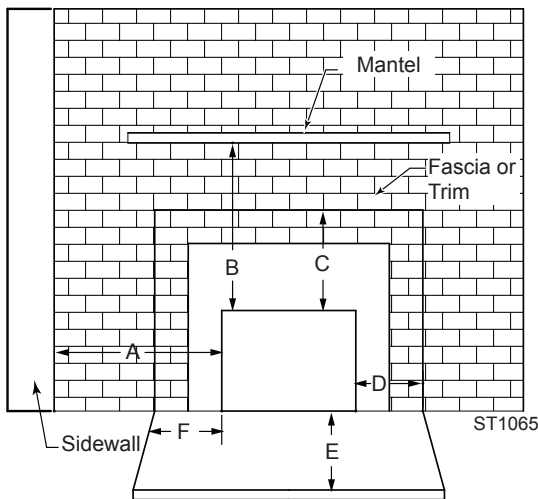

Clearance to Combustibles	Minimum
A. To side wall	11" (279 mm)
B. To mantel (12" max.)	23" (584 mm)
C. To top trim (3/4" max.)	16" (406 mm)
D. To side trim (3/4" max.)	7" (178 mm)
Floor Protection	
E. In front of insert (1/2" min.)	18" (457 mm)
F. To side of insert	8" (203 mm)

Figure 3 - Clearances to Combustibles

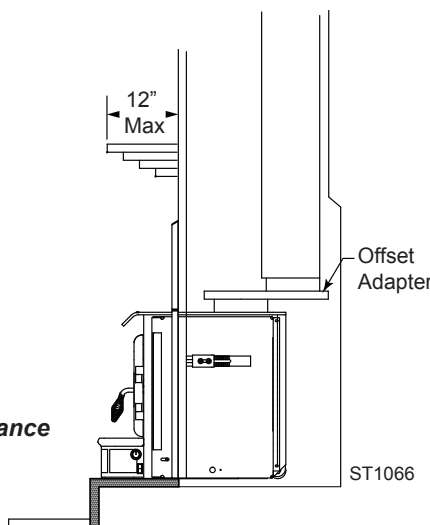

Figure 4 - Mantel Clearance

FLOOR PROTECTION

Floor protection must be at least 1/2" minimum non-combustible material with a "K" value of 0.84, extending 18" (457 mm) in front of and 8" (203 mm) to the side of the fuel loading door (in the United States). In Canada, it must extend 450 mm to the front and 200 mm to the side of the unit.

CALCULATING ACCEPTABLE ALTERNATE FLOOR MATERIALS

All floor protection must be non-combustible (i.e. metal, brick, stone, mineral fiber, etc.). Any organic materials (i.e. plastics, wood or paper products, etc.) are combustible and must not be used. The floor protection specified includes some form of thermal designation such as R-value (thermal resistance) or k-factor (thermal conductivity).

PROCEDURE:

- Convert specification to R-value:
 - R-value given. No conversion needed.
 - k-factor is given with a required thickness (T) in inches: $R = (1/k \times T)$
 - k-factor is given with a required thickness (T) in inches: $R = (1/K \times 12) \times T$
 - r-factor is given with a required thickness (T) in inches: $R = r \times T$
- Determine the R-value of the proposed alternate floor protector.
 - Use the formula in step (1) to convert values not expressed as "R."
 - For multiple layers, add R-values of each layer to determine overall R-value.
- If the overall R-value of the system is greater than the R-value of the specified floor protector, the alternate is acceptable.

EXAMPLE: The specified floor protector should be 3/4" thick material with a k-factor of 0.84. The proposed alternate is 4" brick with an R-factor of 0.2 over 1/8" mineral board with a k-factor of 0.29.

Step A. Use formula above to convert specification to R-value. $R = (1/k) \times T = (1/.84) \times 0.75 = 0.893$

Step B. Calculate R of proposed system.

4" brick of $R = 0.2$, therefore: $R_{brick} = 0.2 \times 4 = 0.431$

1/8" mineral board of $k = 0.29$, therefore: $R_{mineral\ board} = \frac{1}{k} \times T = \frac{1}{0.29} \times 0.125 = 0.431$

$R_{total} = R_{brick} + R_{mineral\ board} = 0.8 + 0.431 = 1.231$

Step C. Compare proposed system R_{total} of 1.231 to specified R of 0.893. Since proposed system R_{total} is greater than required, the system is acceptable.

$$R = \frac{(ft^2)(hr)(\text{°}F)}{Btu}$$

$$k = \frac{(Btu)(in)}{(ft^2)(hr)(\text{°}F)} = K \times 12$$

$$K = \frac{(Btu)(ft)}{(ft^2)(hr)(\text{°}F)}$$

$$r = \frac{(ft^2)(hr)(\text{°}F)}{(Btu)(in)} = \frac{1}{k}$$

CHIMNEY

Refer to chimney and chimney connector manufacturer's instructions.

Contact your local building authority for approved methods of installation

1. This appliance requires a masonry or pre-manufactured chimney listed to ULCS629 (Canada) and UL 103 HT (USA) sized correctly.
2. If a masonry chimney is used it is advisable to have your chimney inspected for cracks and check the general condition before you install your unit. Re-lining may be required to reduce flue diameter to the appropriate functional size.
3. The chimney should extend at least 3' (914 mm) above the highest point where it passes through the roof, and at least 2' (610 mm) higher than any portion of a building within 10' (3 m). *Figure 5*
4. The chimney connector shall not pass through an attic, roof space, closet, concealed space, floor, ceiling, wall or any partition of combustible construction.
5. The minimum overall height of your chimney should be 15' (5 m) from the floor.
6. Do not use makeshift compromises during installation.

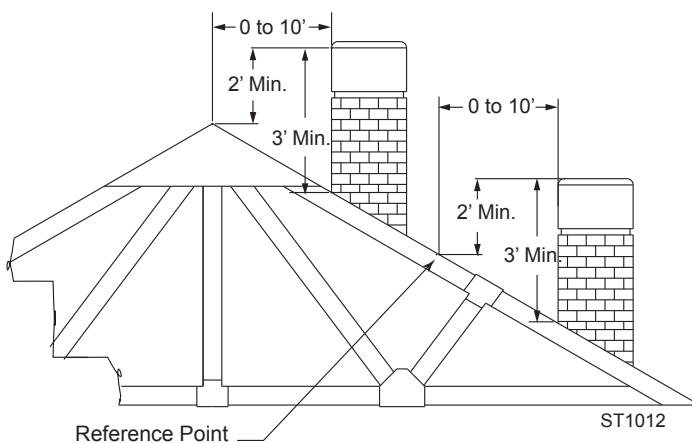

**Figure 5 -
The 2'-3'-10' Chimney Rule**

At the very least, inspect the chimney connector and chimney at least once every two months during the heating season to determine if a buildup of creosote or soot has occurred. If a significant layer of creosote has accumulated (1/8" (3 mm) or more), or if soot has accumulated, either should be removed to reduce the risk of a chimney fire. Failure to keep the chimney and connector system clean can result in a serious chimney fire.

The conditions for a chimney fire develop as follows: When wood is burned slowly, it produces tar and other organic vapors which combine with expelled moisture to form creosote. The creosote vapors condense in the relatively cool chimney flue of a slow burning fire. As a result creosote residue accumulates on the flue lining. Creosote is a flammable and, when ignited, make an extremely hot fire within the flue system which can damage the chimney and overheat adjacent combustible material.

To reduce the amount of creosote that may form, remember to provide adequate air for combustion and to strive for small, intense fires rather than large smoldering ones.

You can never be too safe. Contact your local fire authority for information on what to do in the event of a chimney fire, and have a clearly understood plan on how to handle one.

NOTES ON CHIMNEY AND INSERTPIPE INSULATION:

Maintaining a clean chimney is important. Chimneys should be inspected regularly for creosote buildup. A straight chimney is easier to clean than one with 45 or 90 degree bends. A bend requires the pipe to be removed for cleaning. The insert baffle must be removed when cleaning the chimney. *Page 18*. Chimney sweepings will build up on top of baffle causing a blocked flue and/or a fire hazard.

Steel Chimney

Most factory made "Class A" steel chimneys have a layer of insulation around the inner flue. This insulation keeps the smoke warm and protects the surrounding structure from the high flue temperatures. Because the insulation is less dense than masonry, the inner steel liner warms up more quickly than masonry chimney; this makes the steel chimney support a good draft more quickly than masonry does.

Indoor/Outdoor Location

Because the chimney's function is to keep the smoke warm, it is best to locate it inside the house. This location uses the house as insulation for the flue and allows some radiant heat release from the flue into the home. Since an interior chimney doesn't continuously lose its heat to the outdoors, less heat from the insert is required to get it warm and keep it warm.

Flue Sizing

The flue size for a controlled-combustion appliance should be based on the cross-sectional volume of the insert flue outlet. In this case, more is definitely not better. Hot gases lose heat through expansion; if a insert with a six-inch flue collar (28 square inch area) is vented into a 10" x 10" flue, the gases will expand to over three times their original volume. As gases cool with expansion, draft strength decreases. If the oversized flue is also outside the house, the heat it absorbs will be conducted to the outdoor air and the flue will remain relatively cool.

It is common for a masonry flue to be oversized for the insert. Such a chimney can take quite a while to warm up, and the insert performance will likely be disappointing. The best solution to an oversize flue problem is the installation of an insulated steel chimney liner of the same diameter as the appliance flue outlet. The liner keeps the exhaust gas warm and the result is a stronger draft. An uninsulated liner is a second choice—although the liner will keep the exhaust restricted to its original volume, the air around the liner will require time and heat energy to warm up.

Check your local codes. You may be required to install a flue liner in any oversize masonry flue.

Masonry Chimney

Although masonry is the traditional material used for chimney construction, it can have distinct performance disadvantages when used to vent a controlled combustion wood insert. Masonry forms an effective “heat sink”—that is, it absorbs and holds heat for long periods of time.

The large mass however, may take a long time to become hot enough to sustain a strong draft. The larger the chimney (in total mass) the longer it will take to warm up. Cold masonry will actually cool exhaust gases enough to diminish draft strength. This problem is worse if the chimney is located outside the home or if the chimney flue has a cross-sectional volume much larger than the insert outlet.

Pipe and Chimney Layout

Every bend in the flue will act as a brake on the exhaust as it flows from the firebox to the chimney cap. The ideal pipe and chimney layout is straight up from the insert through completely straight chimney. Use this layout if at all possible, as it will promote optimum insert performance and simplify maintenance.

If the insert pipe must elbow to enter a chimney, locate the elbow about midway between the insert top and the chimney thimble. This configuration lets the smoke speed up before it must turn, keeps some pipe in the room for heat transfer, and allows long-term flexibility for installing a different appliance without relocating the thimble. There should be no more than eight feet of single-wall insert pipe between the insert and a chimney. Longer runs can cool the smoke enough to cause draft and creosote problems. Use double-wall insert pipe for longer runs.

Single Venting

Your insert requires a dedicated flue. Do not connect the insert to a flue used by any other appliance. Chimney draft is a natural form of energy and follows the path of least resistance. If the insert is vented to a flue that also serves open replace or another appliance, the draft will also pull air through those avenues.

The additional airflow will lower the flue temperatures, reduce draft strength and promote creosote development; overall insert performance will suffer. The effect is similar to that of a vacuum cleaner with a hole in the hose. In some extreme instances, the other appliances can even impose a negative draft and result in a dangerous draft reversal.

UNPACKING AND INSTALLATION INSTRUCTIONS

NOTE: The insert is extremely heavy. Do not attempt to move it without assistance.

- Please read all instructions carefully before beginning. To remove the insert from the pallet you will need a 7/16" wrench or socket.
- If you are placing the insert on a raised hearth you might consider moving the complete unit close to the raised hearth to save some lifting later.
- Remove the two brackets on the front of the insert by removing the four bolts (save the two bolts removed from the front of the insert). *Figure 6*

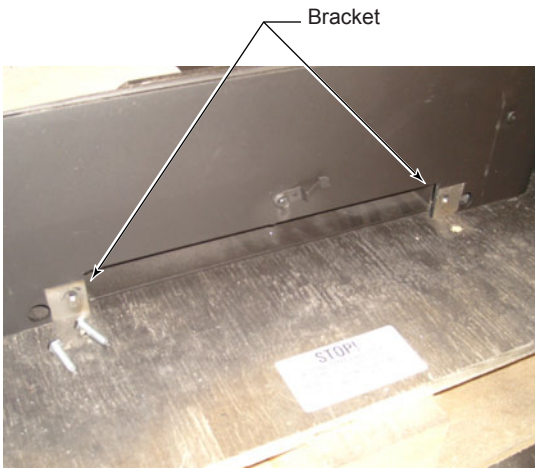

Figure 6

ST1067

- The rear bracket is slipped over the wheel axel and held in place with one (1) bolt. *Figure 7*



Figure 7

ST1068

- If your hearth is not level there are three leveling points on the insert. One on each of the front corners which are easily accessed by sliding the corner of the insert just off the edge of the pallet. *Figure 8*
- If the rear of the insert needs to be adjusted you can slide the rear wheel off the pallet and loosen the two (2) bolts (1/2" wrench). *Figure 9*

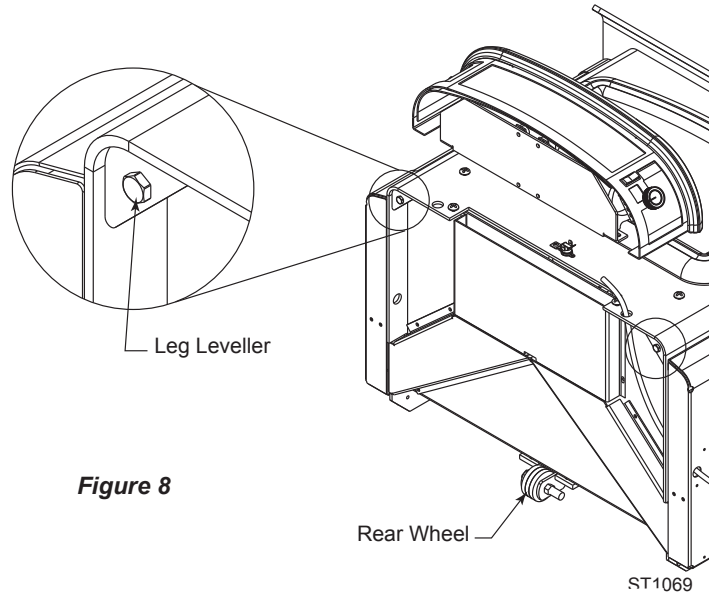

Figure 8

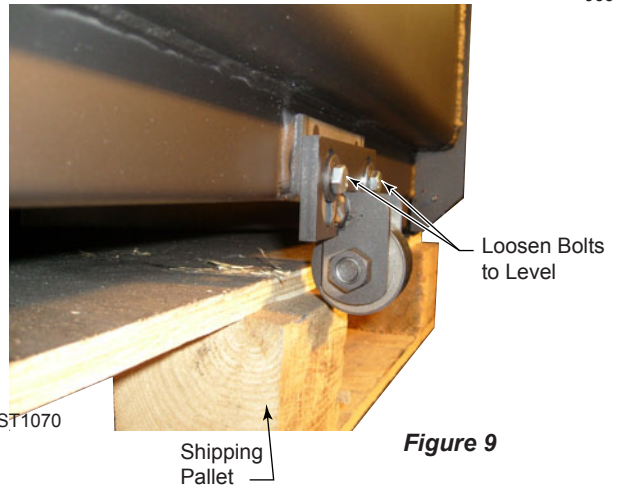

Figure 9

ST1070

- The VCI30 is shipped with the power cord for the blower on the right side. If you want to move it to the left side now is the best time as you can access it under the insert easily by sliding the insert just off the edge of the pallet. Refer to *Page 13* for instructions on converting fan wire from left to right. Make sure you secure the ground wire (green wire) to the side of the insert using the star washer.

Do not attach the blower until the unit is installed in the fireplace.

REMOVING THE FLUE COLLAR

The Savannah insert has a removable flue collar to help with tight installations. You should familiarize yourself with it before you install your insert.

To remove the flue collar you will have to remove the secondary air tubes and the C-cast baffle plates. *Figure 10*

1. Use a Phillips head screw driver or your fingers to remove the drywall screws that are hanging down next to the secondary air tubes. These screws were for shipping purposes only and can be discarded.



Figure 10

ST1071



Figure 12

ST1073

2. To remove the tubes, start by removing the cotter pin on the left end of each tube, then slide the tube to the right until the tube can be pulled down and left, and removed from the insert. Note that each tube is marked with either M (middle) F (front) or R (rear). Be sure you replace the tubes in their correct location to ensure your insert burns at its optimal efficiency. Three new cotter pins have been shipped with the insert.

3. After all three tubes have been removed you can remove the two piece C-cast baffle. *Be very careful not to damage the baffle.* Carefully lift up on the rear piece and move it as far back as possible letting it sit on top of the steel non-removable baffle. Next, lift up on the front piece and move it to the right and allow the left side to angle down into the firebox until it can be removed through the door opening. You can now remove the rear piece the same way. *Figures 11 and 12.*



Figure 11

ST1072



Figure 13

ST1074

4. Remove the bricks from the rear of the insert. This will make turning the flue collar with the chimney liner much easier. *Figure 13*

5. The flue collar has two rotating cam locks that will require the use of a hammer to unlock and lock. *Figure 14* shows the direction the cams need to turn to lock and unlock. The flue collar is made of cast iron and is fairly heavy so you should use something such as a piece of wood to support it. Once the flue collar has been lowered into the firebox you can lower the chimney liner into the collar and fasten it with screws. *Figure 15.* When putting the flue collar with the liner back in place, make sure the ceramic gasket is in place. Use only high temp ceramic fiber gaskets available at your MHSC dealer. **NOTE: The flue collar has one side about 1/2" shorter than the other three. This shorter side must be installed toward the rear of the firebox.** Raise the flue collar chimney assembly and support it in place. Carefully hammer the cam locks over the flue collar alternating from one side to the other until they are parallel to the back of the insert.

6. Replace the C-cast baffle and tubes, remembering to check each tube for the letter M, F or R to be sure you replace them in the correct location. After the tubes are in place check to see that the c-cast baffle is slid back against the steel non-removable baffle as shown in *Figure 16.* Replace the rear bricks.

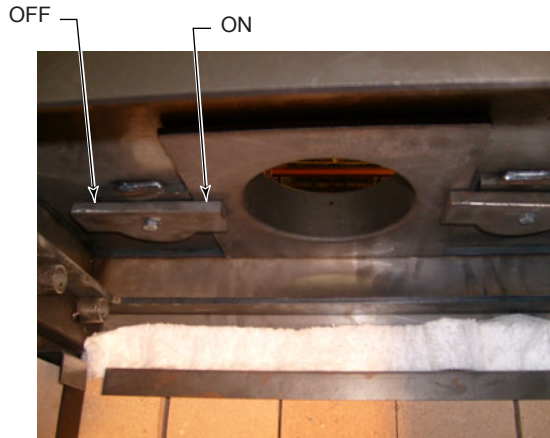

Figure 14

ST1076

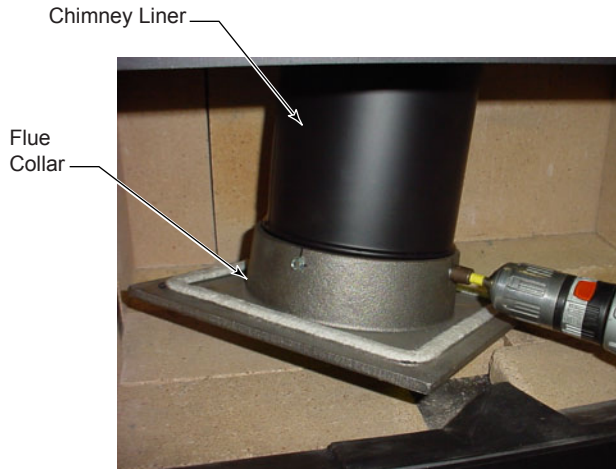

Figure 15

ST1077

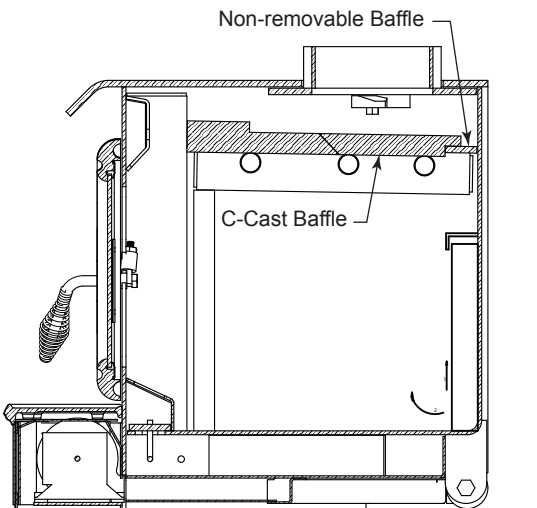

Figure 16

ST1075

FAN WIRING CONVERSION FROM RIGHT TO LEFT

1. Remove ash lip and shroud by lifting straight up. **NOTE:** The ash lip and shroud are held in place by a keyhole slot and bolt system. Lifting up on the ash lip allows the bolt head to slip through the keyhole.

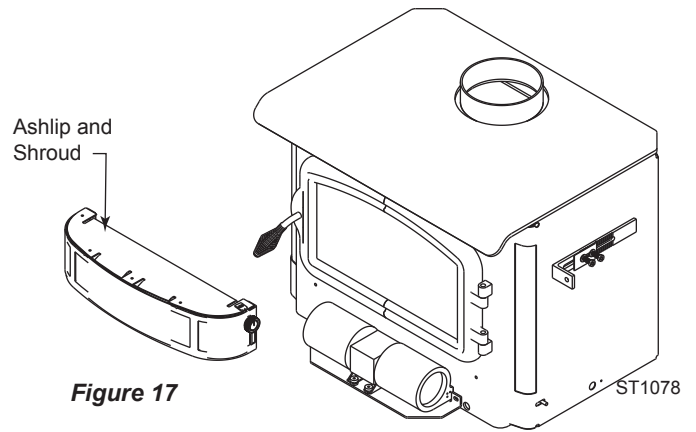

Figure 17

ST1078

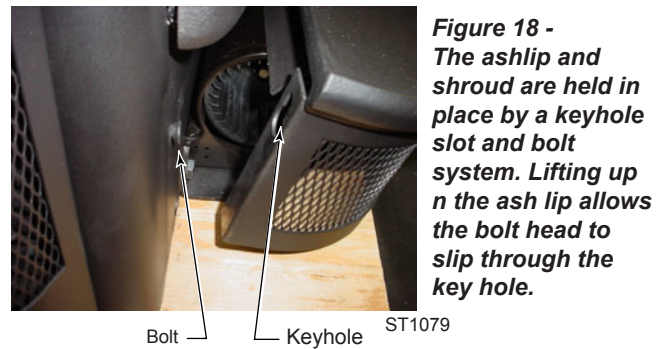

Figure 18 - The ashlip and shroud are held in place by a keyhole slot and bolt system. Lifting up on the ash lip allows the bolt head to slip through the key hole.

ST1079

2. Disconnect ground from side of insert and unplug spade connectors from plug wire.
3. Feed wire through holes in side and front of insert. (Be sure to leave it connected to the fan.) Push wire through opposite side, reconnecting ground and plug wires.

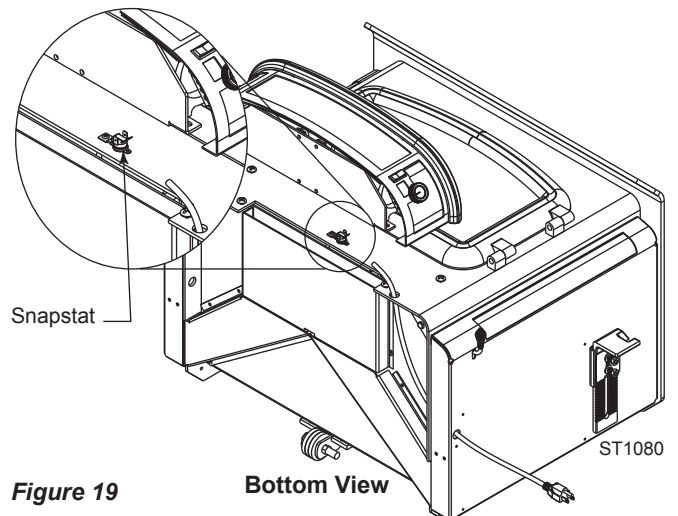

Figure 19

Bottom View

ST1080

BLOWER AND ASH LIP ASSEMBLY

1. Attach the wires as shown in *Figure 20* making sure you push all connections together tightly
2. Insert the snapstat into its holder as shown in *Figure 19*, making sure that the connectors are not touching the insert.
3. Use the two bolts saved from the front shipping bracket to secure the blower to the insert.
4. Make sure all wires are away from the insert front.
5. The ash lip and surround can now be installed by placing the keyhole cutouts over the bolt heads shown in *Figure 18*.

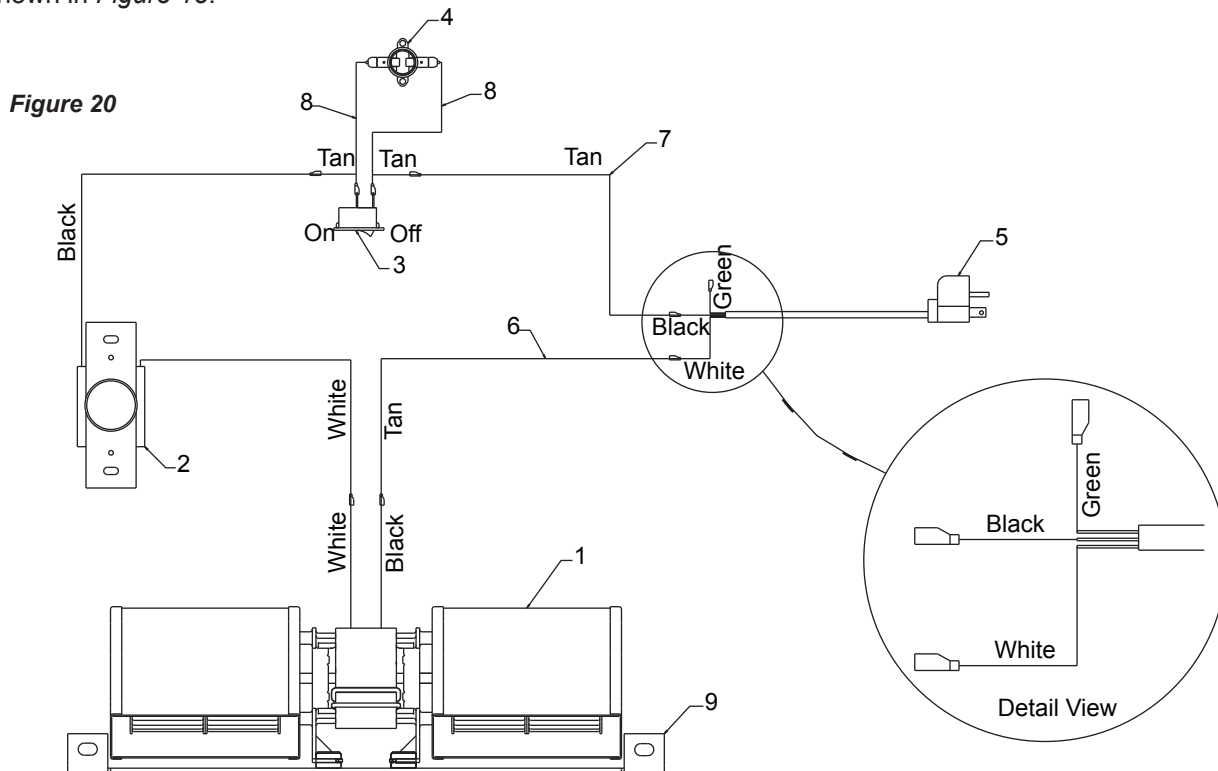

ASSEMBLING THE SURROUND

To assemble the surround it is best to lay the three sections face down on a soft flat surface. The foam package material works well for this.

Align the two pins on the top section with the holes on the side pieces as shown in *Figure 21*. Carefully slide the sections together. When moving the assembled surround it is best to hold it by the sides and not the top.

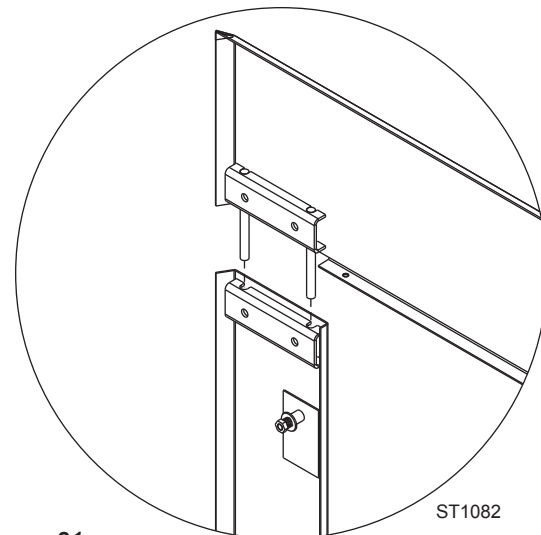

Figure 21

SURROUND INSTALLATION

To install the surround on the insert, make sure the ratcheting brackets are in their forward most position. Lift the surround over the primary air control rod and set the spring loaded washers over the cast ratchet brackets and allow the threaded stud to slide into the notch as shown in *Figure 22*.

Once both sides are securely attached to the ratchet brackets gently start sliding the surround back towards the wall making sure to keep both sides even. Pushing directly in front of the brackets will help keep the surround straight.

To remove the surround from the insert, simply lift the surround straight up until it becomes free of the brackets. Remember to slide the brackets to their forward most position before trying to install the surround again.

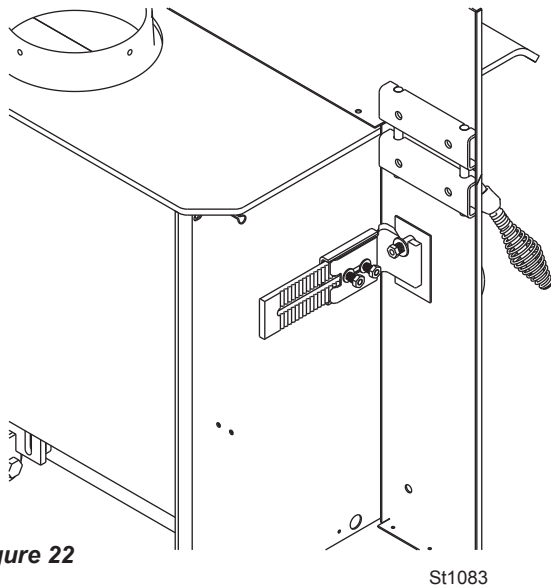

Figure 22

INSTALLATION INTO A MASONRY FIRE-PLACE

The best installation is the complete relining of the chimney system using a 6" listed stainless steel liner. The liner must be attached to the insert and to each section of the liner with the crimped (male) end pointing toward the insert. All connections should be secured with a minimum of 3 screws, this includes the flue collar.

NOTE: Canadian installations require a full reline of the chimney.

The next type of installation is a direct connection to the first flue liner in accordance with the requirements of the NFPA 211. Secure the fireplace damper in the open position or remove it. Seal the area around the starter pipe and the damper opening with high temp sealant and or sheet metal.

The chimney should be inspected for cracks, loose mortar and any other signs of deterioration or blockage. Always check with your local building code agency before you begin your installation to ensure compliance with local codes, including the need for permits and any follow up inspections.

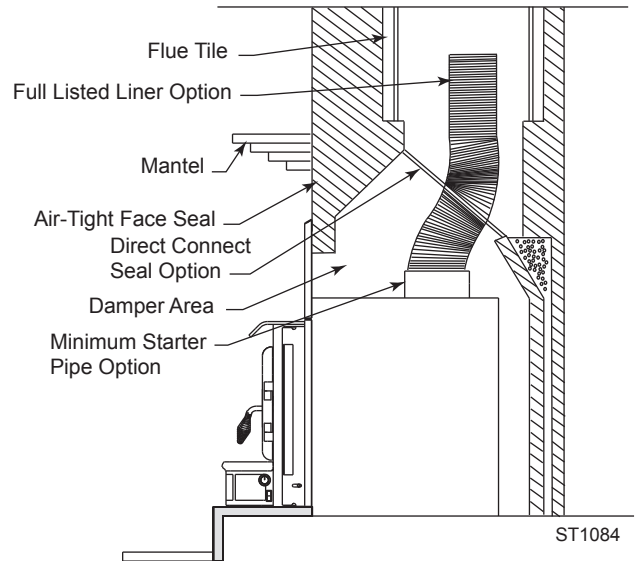

Figure 23 - Installation into Masonry Fireplace

INSTALLATION IN CANADA

Whether installed in a masonry or heat -circulating fireplace, this fireplace insert must be installed with a continuous chimney liner of 6" (152 mm) diameter extending from the fireplace insert to the top of the chimney. The chimney liner must conform to the Class 3 requirements of CAN/ULC-S635, *Standard for Lining Systems for Existing Masonry or Factory-Built Chimneys and Vents*, or CAN/ULC-S640, *Standard for Lining Systems for New Masonry Chimneys*.

- Do not remove bricks or mortar from fireplace to accommodate insert.
- The permanent metal warning label provided must be affixed to the back of the fireplace with screws or nails, in a location readily visible should the fireplace insert be removed. This label states that the fireplace may have been altered to accommodate the insert, and must be returned to original condition for use as a conventional fireplace.

INSTALLATION INTO A FACTORY BUILT FIRE-PLACE

Make sure the factory built fireplace is large enough for your insert. Do not modify the fireplace. (Exceptions: removal of the damper, removal of the smoke shelf or baffle, grate, doors and or screens.) The metal label supplied with your

insert **must** be attached to the back of the fireplace with screws or nails. This label states that the fireplace may have been altered to accommodate the insert, and must be returned to original condition for use as a conventional fireplace.

A complete chimney reline is required in most installations. Always check with the fireplace manufacturer. If a complete reline is required, the liner must be attached directly to the flue collar and run all the way to the chimney cap. The liner must meet type HT requirements (2100°F) per UL 1777. To prevent room air from escaping up the chimney cavity, seal around the liner with high temp insulation or sheet metal.

INSTALLATION OF OFFSET FLUE COLLAR

Offset flue collars are available in two sizes (3" and 6") from your MHSC dealer for your Savannah insert. When installing an offset flue collar it is important that the offset adapter be secured with at least three screws into the insert flue collar and three screws into the chimney liner. Make sure that the offset flue collar is installed inside of the insert flue collar and the chimney liner is installed inside the offset adapter. *Figure 24*

WARNING: Never allow the offset flue collar to support the weight of the chimney liner. The liner must be supported at the top of the chimney.

As with all installations, final approval of this installation type is contingent upon the authority having jurisdiction in your area.

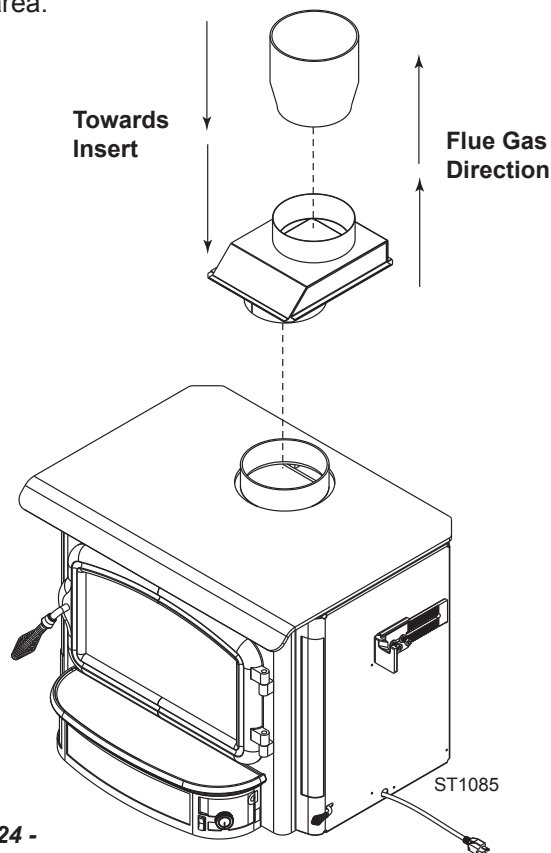

Figure 24 -
Offset Flue Collar Installation

OPERATION

To reduce the amount of creosote that may form, remember to provide adequate air for combustion and to strive for small, intense fires rather than large smoldering ones. You can never be too safe. Contact your local fire authority for information on what to do in the event of a chimney fire, and have a clearly understood plan on how to handle one.

Do not use a grate or elevate fire. Build wood fire directly on firebrick. When the insert is used for the first time the solvents in the paint will smoke off.

Wood

This heater is designed to burn natural wood only. Higher efficiencies and lower emissions generally result when burning air dried seasoned hardwoods, as compared to softwoods or to green or freshly cut hardwoods. Only use dry seasoned wood. Green wood, besides burning at only 60 percent of the fuel value of dry wood, deposits creosote on the inside of your insert and along the chimney. This can cause an extreme danger of chimney fire. To be called "seasoned," wood must be dried for a year. Regardless of whether the wood is green or seasoned, it should be stored in a well-sheltered ventilated area to allow proper drying during the year to come. Wood should be stored beyond recommended clearance from combustibles.

Fuel

Even the best insert installation will not perform well with poor fuel. If available, always use hardwood that has been air-dried (seasoned) 12-18 months. Softwood burns more rapidly than hardwood and has a high pitch content that can result in creosote. Decayed wood of any type has little heat value and should not be used.

Unseasoned (green) wood has a high moisture content. Much of its heat value will be used to evaporate moisture before the wood can burn. This significantly reduces the amount of energy available to warm your home, as well as the intensity of the fire and temperature of the exhaust gas. Incomplete combustion and cool flue temperatures promote creosote formation and weak draft.

You can judge the moisture content of wood by its appearance and weight or use a commercially available moisture meter for exact measurement. Unseasoned wood will be a third heavier than dry wood. Also look for cracks (checking) in the ends of the log that result from contraction as the wood dries. The longer and wider the cracks are, the dryer the wood is.

Creosote

Creosote is a by-product of low-temperature insert operation, weak draft or both. It is a tar that results when unburned gases condense inside the flue system at temperatures below 290 degrees F. Creosote is volatile and can generate a chimney fire. All of the installation characteristics that adversely affect chimney draft also

promote creosote condensation. Consequently, you can minimize creosote accumulation with an effective chimney design and the use of operational techniques that encourage good draft and complete combustion.

Inspect your chimney frequently and clean it whenever accumulation exceeds 1/4".

When wood is burned slowly, it produces tar and other organic vapors. These combine with moisture to form creosote. Creosote vapors condense in the relatively cool chimney flue of a slow burning fire. As a result, creosote residue accumulates on the flue lining. When ignited, this creosote makes an extremely hot fire. The chimney should be inspected regularly during the heating season to determine if a creosote build-up has accumulated. If this is the case, the creosote should be removed to reduce the risk of chimney fire.

KEEP UNIT FREE OF CREOSOTE

1. Burn with air control open for several minutes at numerous intervals throughout the day during the heating season, being careful not to over-fire unit. This removes the slight film of creosote accumulated during low burn periods.
2. Burn insert with draft control wide open for several minutes every time you apply fresh wood. This allows wood to achieve the charcoal stage faster and burns wood vapors which might otherwise be deposited within the systems.
3. **BURN ONLY SEASONED WOOD.** Avoid burning wet or green wood. Seasoned wood has been dried for at least one year.
4. A small hot fire is preferable to a large smoldering one that can deposit creosote within the system.
5. Establish a routine for the fuel, wood burner and firing technique. Check daily for creosote build-up until experience shows how often you need to clean to be safe. Be aware that the hotter the fire, the less creosote is deposited and weekly cleaning may be necessary in mild weather even though monthly cleaning may be enough in the coldest months. Contact your local municipal authority for information on how to handle a chimney fire. Have a clearly understood plan to handle a chimney fire.

DO NOT BURN: Treated wood, solvents, trash, coal, garbage, cardboard, colored paper

NEVER USE GASOLINE, GASOLINE-TYPE LANTERN FUEL, KEROSENE, CHARCOAL LIGHTER FLUID, OR SIMILAR LIQUIDS TO START OR "FRESHEN UP" A FIRE IN THIS HEATER. KEEP ALL SUCH LIQUIDS WELL AWAY FROM THE HEATER WHILE IT IS IN USE

INSTRUCTION FOR FIRST BURN – CURING THE INSERT PAINT

Your insert has been painted with the highest quality insert paint and has special break-in procedures. The heat generated by the normal operation of the insert, will serve to harden the paint.

NEGATIVE PRESSURE

Good draft also depends on a supply of air to the insert; a chimney can't pull in more air than is available to it. Sluggish draft results when a house is tight enough to prevent the ready flow of air to the insert, or by competition between the insert and other equipment that sends indoor air outside - especially power-driven equipment like range hoods, exhaust fans, clothes dryers, etc. If the chimney draws well with all other equipment turned off (or sealed, in the case of fireplaces and/or other inserts), then you simply need to be careful with timing the use of the other equipment. Note that negative pressure resulting in inadequate indoor combustion air may trigger nearby smoke detectors. If you need to crack a nearby window or door to enable the chimney to draw well, that's a sign that you should install an outside-air intake to bring combustion air directly to the insert. MHSC dealers carry adapters to attach to the insert to connect an air duct for outdoor combustion air.

Ventilate the house during the first three times the insert is used. The paint on the insert will give off smoke, carbon dioxide and an odor. Without adequate ventilation, concentrations of smoke could irritate, or be upsetting. **Open doors and windows and use a fan** if necessary. After the initial burns the paint will be cured and there should be no more smoke. Each of the initial burns should be conducted as follows:

- A) The first two burns should be at approximately 250° F (120° C) for approximately 20 minutes.
- B) The third burn should be between 500° F and 700° F (260° to 370° C) for at least 45 minutes. The important fact is the paint should be cured slowly. Avoid hot fires during the curing process.

The best way to achieve the first burn is with kindling fires. Prolong the fires as needed by adding more kindling. During the curing process the paint may be gummy. Once cured the paint will remain hard. **It is normal** to see flat spots on painted surfaces of the insert. The flat spots on the paint surface indicate the hotter surfaces of the insert, and is caused by the heat radiating through the paint. **It is also expected that shiny spots** caused by friction from the packaging materials, will disappear during the curing of the insert.

So:

1. Remember to ventilate well.
2. Allow the insert to cure before burning for long periods at high temperatures.

- Flat spots on the painted surfaces are normal.
- Shiny spots on the paint surface before burning is normal.
- Call your dealer if you have any questions.

BUILDING A FIRE

- Open inlet air control fully.
- Place a small amount of crumpled paper in the insert.
- Cover the paper with a generous amount of kindling wood in a teepee fashion and a few small pieces of wood.
- Ignite the paper and close door. If fire dies down substantially, open door slightly.
- Add larger pieces of wood as the fire progresses being careful not to overload. Do not fill firebox beyond firebrick area. An ideal coal bed of 1" (25 mm) to 2" (50 mm) should be established to achieve optimum performance.
- This unit is designed to function most effectively when air is allowed to circulate to all areas of the firebox. An ideal means of achieving this is to rake a slight (1" to 2" wide) trough in the center of the coal bed from front to back prior to loading the fuel.

CAUTION: TO REDUCE THE RISK OF GLASS BREAKAGE, AVOID LOCATING WOOD FUEL CLOSE TO, OR TOUCHING THE DOOR GLASS.

- Once fuel has been loaded, close door and open air inlet control fully until fire is well established (approx. 10 minutes) being careful not to over fire.
- Re-adjust air inlet control to desired burn rate. If excessive smoke fills firebox, open air inlet control slightly until flames resume and wood is sufficiently ignited. A basic rule of thumb is "closed – low," "half way-medium," and "fully open – high."
- When refueling, adjust air control to the fully open position. When fire brightens, slowly and carefully open the door. This procedure will prevent gases from igniting causing smoke and flame spillage.
- Add fuel being careful not to overload.
- Close doors.

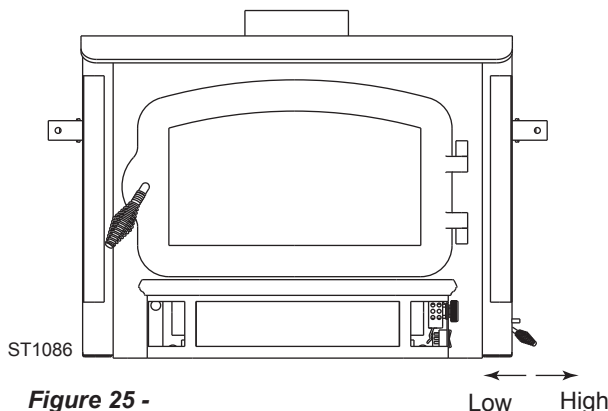

**Figure 25 -
Air Control Layout**

REMOVE BAFFLE

To remove the tubes you will start by removing the cotter pin on the left end of each tube, then slide the tube to the right until the tube can be pulled down and left and removed from the insert. Note that each tube is marked with either M, for middle F, for front or R for rear, be sure you replace the tubes in their right location to insure you insert burns at it best efficiency. 3 new cotter pins have been shipped with the insert.

After all 3 tubes have been removed you can remove the 2 piece c-cast baffle, be very careful not to damage the baffle, carefully lift up on the rear piece and move it as far back as possible letting it set on top of the steel non-removable baffle. Next lift up on the front piece and move it to the right and allow the left side to angle down into the firebox until it can be removed thru the door opening. You can now remove the rear piece the same way. NOTE: See *Figures 11 and 12* on Page 12 for more information.

REMOVING FIREBRICK

To remove firebrick, lift up from bottom and rotate outward. *Page 12, Figure 13*

CLEANING YOUR CHIMNEY

The Savannah SSI30 insert has a removable baffle which allows the chimney to be cleaned without removing the insert from the fireplace.

Make sure the insert is cool before proceeding

To remove the rear of the baffle, reach in through the door and lift up on the rear half of the baffle and, very carefully with your fingers, walk the rear half of the baffle up and onto of the front half of the baffle. Make sure you slide it far enough forward so the chimney brush will not damage it when cleaning. *Figure 26*. There is no need to remove the secondary air tubes for cleaning.

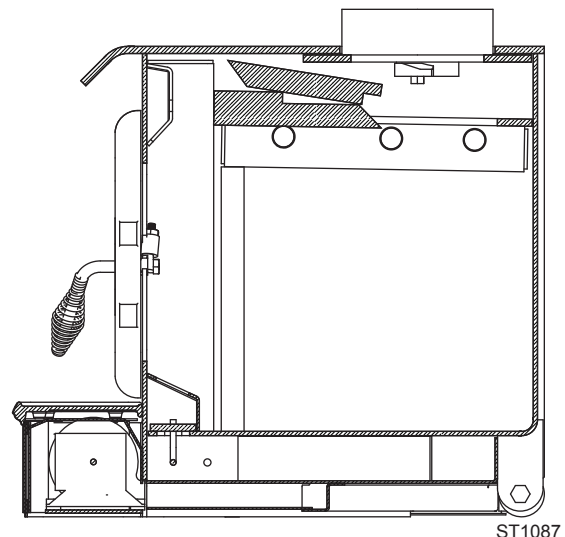

**Figure 26 -
Remove Baffle**

After the chimney has been cleaned clean out the firebox and carefully replace the rear half of the baffle. Check to see that both pieces of the baffle are down on the steel baffle and pushed all the way to the rear of the firebox.

Figure 27

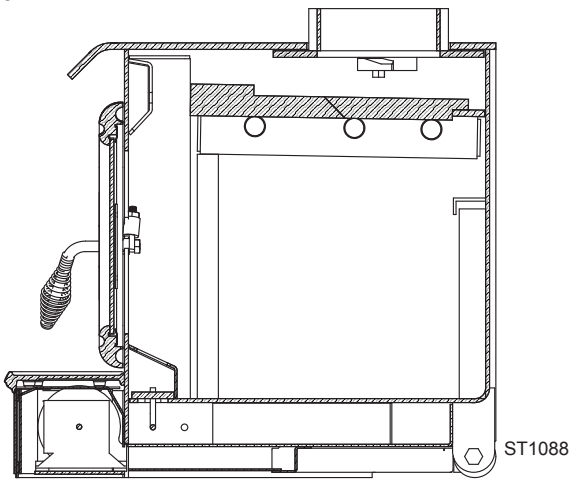

Figure 27 -
Replace Baffle

REPLACE GLASS ONLY WITH HIGH TEMPERATURE CERAMIC AVAILABLE FROM YOUR LOCAL MHSC DEALER

Use of glass or other components from alternative sources may cause a safety hazard and may void your warranty.

The following use and safety tips should be observed:

1. Inspect the glass regularly for cracks and breaks. If you detect a crack or break, extinguish the fire immediately, and contact your dealer for replacement.
2. Do not slam door or otherwise impact the glass. When closing doors, make sure that logs or other objects do not protrude to impact the glass.
3. Do not clean the glass with materials which may scratch (or otherwise damage) the glass. Scratches on the glass can develop into cracks or breaks.
4. Never attempt to clean the glass while unit is hot. Light deposits are normal. Heavier deposits may be removed with the use of a readily available oven cleaner.
5. Never put substances which can ignite explosively in the unit since even small explosions in confined areas can blow out the glass.
6. This unit has an air wash system designed to reduce deposits on glass.

GASKET REPLACEMENT

After extensive use, the gasket material which provides glass and door seal may need to be replaced if it fails to sustain its resilience. Inspect glass and door seal periodically to ensure proper seal: if gaskets become frayed or worn, replace immediately. Contact your dealer for approved replacement parts. Refer to replacement parts list in this manual.

NOTE: Wear safety glasses and gloves when performing any maintenance task.

The following steps should be followed for glass gasket replacement:

1. Ensure appliance is not in operation and is thoroughly cooled
2. Remove door and place on a protected flat surface.
3. Remove screws and glass clips.
4. Lift glass out.
5. Remove old gasket and clean or replace glass.
6. Sand gasket groove and wipe clean (rubbing alcohol works well).
7. Put a thin film of gasket cement on the door.
8. Replace new gasket starting at the top center of the door.
9. Trim to length and butt ends together. Remove all excess cement.
10. Replace glass in door, being sure not to over-tighten screws and clips.

DOOR GASKET REPLACEMENT

The following steps should be followed for door gasket replacement:

1. Ensure appliance is not in operation and is thoroughly cooled.
2. Remove door and place on a protected flat surface.
3. Remove old door gasket and clean channel.
4. Sand gasket groove and wipe clean (rubbing alcohol works well).
5. Using an approved high temperature gasket cement, apply a thin coat in bottom of channel.
6. Starting at top center of door, work into channel around door unit, trim to length and butt ends.
7. Close door and allow three to four hours for cement to set before restarting appliance.

ASH DISPOSAL

Ashes should be placed in a metal container with a tight-fitting lid. The closed container of ashes should be placed on a non-combustible floor or on the ground, well away from all combustible materials, pending final disposal. If the ashes are disposed of by burial in soil or otherwise locally dispersed, they should be retained in the closed container until all cinders have thoroughly cooled. Other waste should not be placed in the ash container.

WARNING	THINGS TO REMEMBER IN CASE OF CHIMNEY FIRE:
	1. CLOSE DRAFT CONTROL
	2. CALL THE FIRE DEPARTMENT

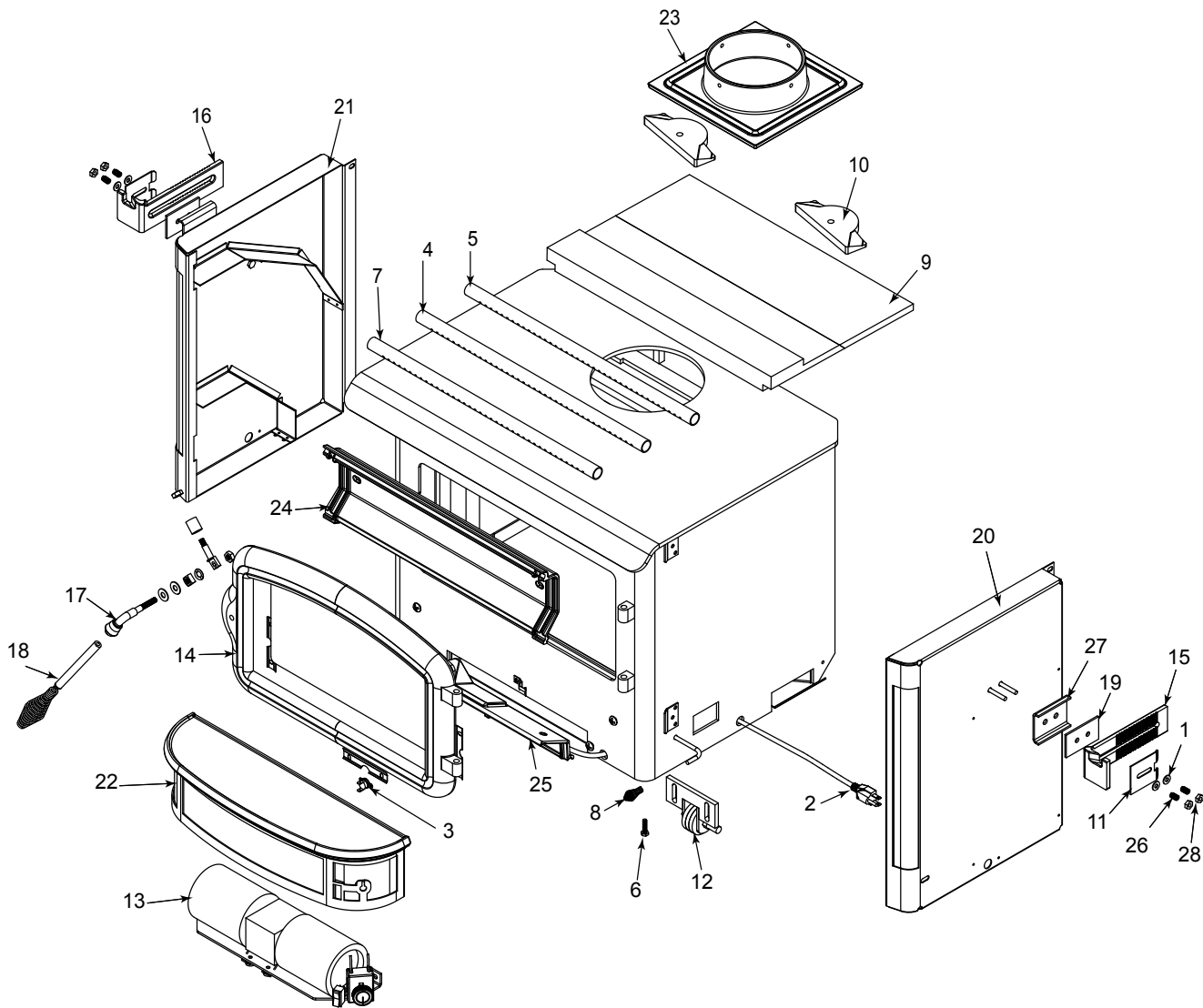

SSI30 Wood Insert Insert

Ref.	Description	SSI30
1.	5/16" Washer	20H2032
2.	Blower Cord	26D0619
3.	Blower Thermo Disc	49D0130
4.	Secondary Air Tube, Middle	63D0026
5.	Secondary Air Tube, Rear	63D0028
6.	Leveler Bolt	63D0065
7.	Secondary Air Tube, Front	63D0112
8.	Spring Handle	63D0185
9.	C-Cast Assembly	63D2004
10.	Turn Tight Cast Iron	63D2022
11.	Slider	63D2040
12.	Rear Wheel Assy.	63D2072
13.	Blower Assy.	63D2075
14.	Cast Door Assy, Complete	63D2077
15.	Surround Clamp, Right	63D2081
16.	Surround Clamp, Left	63D2082

SSI30 Wood Insert Insert (continued)

Ref.	Description	SSI30
17.	Glass Door Handle Assy.	63D2084
18.	Fall-Away Handle Assy.	63D2085
19.	Adjustment Slide Plate	63D2090
20.	Right Side Shroud	63D2100
21.	Left Side Shroud	63D2102
22.	Blower Enclosure Assy.	63D2105
23.	Pipe Collar Assy.	63D2111
24.	Air Wash Assy.	63D2113
25.	Cast Iron Primary Air Cover Assy.	63D2130
26.	Spring	63D2145
27.	Capture Plate	63D2146
28.	Lock Nut	63D4040

FREQUENTLY ASKED QUESTIONS

1. What is the correct way to start a fire?

- a) You will need small pieces of dry wood (kindling) and paper. Use only newspaper or paper that has not been coated or had unknown materials glued or applied to it. **Never** use coated (typically advertising flyers) or colored paper.
- b) Open the door of the wood insert.
- c) Crumple several pieces of paper and place them in the center of the firebox and directly on to the firebricks of the wood insert. **Never** use a grate to elevate the fire.
- d) Place small pieces of dry wood (kindling) over the paper in a “Teepee” manner. This allows for good air circulation, which is critical for good combustion.
- e) Light the crumpled paper in 2 or 3 locations. **NOTE:** *It is important to heat the air in the insertpipe for draft to start.*
- f) Fully open the air control of the wood insert (Page 14) and close the door until it is slightly open, allowing for much needed air to be introduced into the firebox. Never leave the door fully open as sparks from the kindling may occur causing injury. As the fire begins to burn the kindling, some additional kindling may be needed to sustain the fire. DO NOT add more paper after the fire has started.
- g) Once the kindling has started to burn, start by adding some of your smaller pieces of seasoned (dry) firewood. *Note: Adding large pieces at the early stages will only serve to smother the fire.* Continue adding small pieces of seasoned (dry) firewood, keeping the door slightly open until each piece starts to ignite. Remember to always open the door slowly between placing wood into the fire.
- h) Once the wood has started to ignite and the smoke has reduced, close the wood insert door fully. The reduction of smoke, is a good indication that the draft in the chimney has started and good combustion is now possible. Larger pieces of seasoned (dry) firewood can now be added when there is sufficient space in the firebox. Adjust the air control setting to desired setting (**Page 12**)
- i) **NOTE:** The lower the air control setting the longer the burn time of your firewood.

2. What type of wood is best to use as firewood?

Dry seasoned hardwood should be used. Avoid green unseasoned wood. Green wood, besides burning at only 60 percent of the fuel value of dry seasoned wood, will deposit creosote on the inside of your insert and along the inside of your chimney.

3. What does dry seasoned wood mean, and what is considered hardwood?

Wood that has been dried for a period of one year in a well-ventilated and sheltered area would be considered dry seasoned wood. Hardwoods are generally from slow growth trees (Example: Oak and Fir). Softwoods are generally from fast growth trees (Example: Pine and Spruce).

4. Will following the above listed steps for starting a fire result in perfect results all the time?

The quick answer is most of the time. There are many variables that may affect your success rate when starting a fire. Most of those variables and how to deal with them will be learned through experience. Your ability to start a good fire will significantly increase with time and patience. Some of the reasons for poor insert performance will be covered in the next section of these instructions

5. Why can't I get the fire lit?

Damp or wet wood and poor draft are the main reasons for poor results in starting a fire. Always use dry seasoned wood for your fire. Even wood dried for two years will be difficult to ignite if it has become wet.

6. Why is there always a large quantity of thick black smoke present in the firebox?

A large quantity of thick black smoke in the firebox is a good indication that the draft is poor.

7. Is it normal for soot to cover the glass at the beginning of a fire?

Your insert has been built with an air wash system that will help keep the glass clear when the firebox has reached a good operating temperature, and has a good draft. Cold firebox temperature and poor draft cause sooting of the glass. Once the firebox temperature and the draft increases, the soot will burn off.

8. What is draft?

Draft is the ability of the chimney to exhaust by-products produced during the normal combustion process.

9. What can cause a poor draft?

The most common factors for poor draft are:

- a. Atmospheric pressure and air supply
- b. Environmental condition
- c. Cold chimney temperature
- d. Poor chimney installation and maintenance

a) Atmospheric Pressure and Air Supply

Atmospheric pressure affecting the draft from a chimney can be either outside the home, inside the home or both. Outside the home, a high-pressure day (clear and cool) generally creates a better draft in the chimney than a low-pressure day (overcast and damp). Inside the home normal household appliances, such as clothes dryers and forced air furnaces compete for air, resulting in inadequate amounts of air available to fuel a fire and create a condition known as negative pressure. Under extreme conditions of negative pressure the combustion by-products can be drawn from the chimney into the house. This condition is commonly referred to as down drafting.

There are several factors that impact the amount of air available in the home. Increased amounts of insulation, vinyl windows, extra caulking in various places and door seals can all keep heat in but may also make a home too airtight. If you are in doubt about whether or not there is sufficient air in your home for your insert, curtail from using those appliances known to consume the air where possible, or open a window or door to allow air to enter the home.

b) Environmental Conditions

High trees, low lying house location such as in a valley, tall buildings or structures surrounding your house and windy conditions can cause poor draft or down drafting.

c) Cold Chimney Temperature

Avoid cold chimney temperatures by burning a hot fire for the first fifteen to forty minutes, being careful not to over fire. If any part of the chimney or parts of the insert start to glow, you are over firing the insert. Where possible, install a temperature gauge on the chimney so temperature drops can be seen.

d) Chimney Installation and Maintenance

Avoid using too many elbows or long horizontal runs. If in doubt, contact a chimney expert and/or chimney manufacturer for help. Clean chimney, rain caps and especially spark arrester regularly, to prevent creosote build-up, which will significantly reduce chimney draw and possibly a chimney fire.

11. Should I close or open the air control fully when shutting down the insert?

Just before shutting down the insert, run on high for a few minutes. This allows the chimney temperatures to remain as high as possible for as long as possible. Cold chimney temperatures create creosote.

NOTE: This sheet is intended as an aid and does not supersede any local, provincial or state requirements. Check with officials or authorities having jurisdiction in your area.

MHSC Wood Insert

LIMITED LIFETIME WARRANTY POLICY

LIMITED LIFETIME WARRANTY

The following components are warranted for life to the original owner, subject of proof of purchase: Firebox weldment and baffle supports.

FIVE YEAR WARRANTY

The following components are warranted against deterioration not resulting from physical or handling damage for 5 years to the original owner, subject to proof of purchase: Stainless steel secondary air tubes and secondary ceramic baffle material.

ONE YEAR WARRANTY

MHSC warrants the components and materials in your wood insert to be free from manufacturing and material defects for a period of one year from date of purchase. After installation, if any of the components manufactured by MHSC in the appliance are found to be defective in materials or workmanship, MHSC will, at its option, replace or repair the defective components at no charge to the original owner. MHSC will also pay for reasonable labor costs incurred in replacing or repairing such components for a period of one year from the date of installation. Any products presented for warranty repair must be accompanied by a dated proof of purchase.

This Limited Lifetime Warranty will be void if the appliance is not installed by a qualified installer in accordance with the installation instructions. The Limited Lifetime Warranty will also be void if the appliance is not operated and maintained according to the operating instructions supplied with the appliance, and does not extend to (1) firebox/burner assembly damage by over-firing, over-loading, accident, neglect, misuse, abuse, alteration, negligence of others, including the installation thereof by unqualified installers, (2) the costs of removal, reinstallation or transportation of defective parts on the appliance, or (3) incidental or consequential damage. All service work must be performed by an authorized service representative.

This warranty is expressly in lieu of other warranties, express or implied, including the warranty of merchantability of fitness for purpose and of all other obligations or liabilities. MHSC does not assume for it any other obligations or liability in connection with the sale or use of the appliance. In states that do not allow limitations on how long an implied warranty lasts, or do not allow exclusion of indirect damage, those limitations of exclusions may not apply to you. You may also have additional rights not covered in this Limited Lifetime Warranty.

MHSC reserves the right to investigate any and all claims against the Limited Lifetime Warranty and decide upon method of settlement.

IF WARRANTY SERVICE IS NEEDED...

1. Contact your supplier. Make sure you have your warranty, your sales receipt and the model/serial number of your MHSC product.
2. DO NOT ATTEMPT TO DO ANY SERVICE WORK YOURSELF.

MHSC

149 Cleveland Drive • Paris, Kentucky 40361
www.mhsc.com