



# UNVENTED GAS CAST IRON STOVE INSTALLATION AND OPERATING INSTRUCTIONS

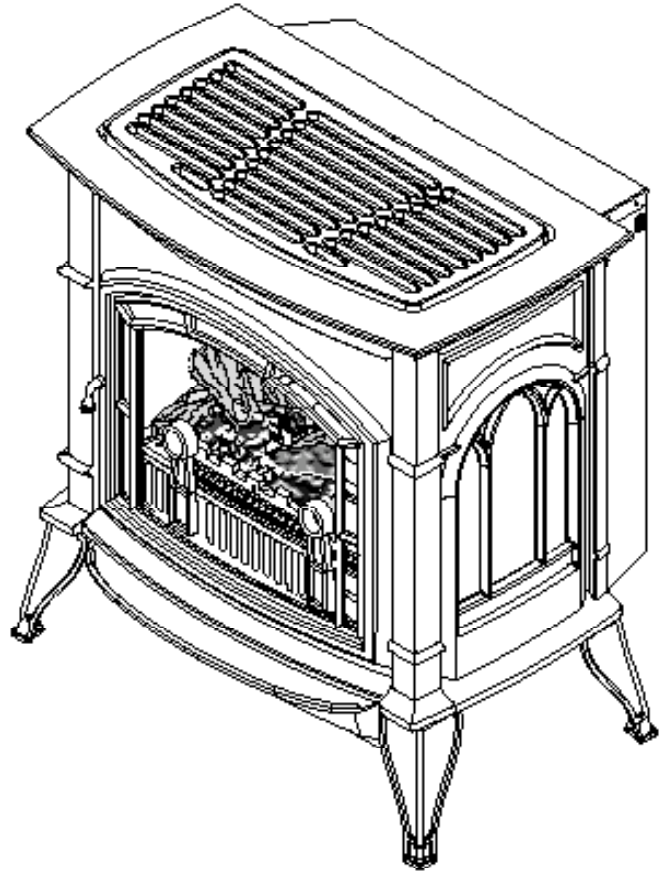
## SINGLE DOOR MODELS:

CSVF20SNV CSVF30SNV  
CSVF20SPV CSVF30SPV

## DOUBLE DOOR MODELS:

VFCS20DNV VFCS30DNV  
VFCS20DPV VFCS30DPV

Natural Gas or Propane/LPG  
Millivolt Control



This appliance may be installed in an aftermarket, permanently located, manufactured (mobile) home, where not prohibited by local codes.

This appliance is only for use with the type of gas indicated on the rating plate. This appliance is not convertible for use with other gases.

This is an unvented gas-fired heater. It uses air (oxygen) from the room in which it is installed. Provisions for adequate combustion and ventilation air must be provided. Refer to page 8.

## WARNINGS

If the information in this manual is not followed exactly, a fire or explosion may result causing property damage, personal injury or loss of life.

- Do not store or use gasoline or other flammable vapors and liquids in the vicinity of this or any other appliance.
- **WHAT TO DO IF YOU SMELL GAS**
  - Do not try to light any appliance.
  - Do not touch any electrical switch; do not use any phone in your building.
  - Immediately call your gas supplier from a neighbor's phone. Follow the gas supplier's instructions.
  - If you cannot reach your gas supplier, call the fire department.
- Installation and service must be performed by a qualified installer, service agency or the gas supplier.

**READ AND SAVE THESE INSTRUCTIONS**

---

# CONTENTS

---

<b>Important Safety Information .....</b>	<b>3</b>	<b>Rock Wool Installation .....</b>	<b>18</b>
<b>Product Features .....</b>	<b>5</b>	<b>Flame Appearance.....</b>	<b>19</b>
<b>Dimensions .....</b>	<b>6</b>	Checking Pilot Flame.....	19
<b>Getting Started.....</b>	<b>7</b>	Checking the Burner Flame .....	20
<b>Product Specifications.....</b>	<b>8</b>	<b>Operating Instructions .....</b>	<b>21</b>
Ignition Controls.....	8	For Your Safety Read Before Lighting .....	21
Pilot.....	8	Millivolt Control Lighting Instructions .....	22
Thermal Generator .....	8	To Turn Off Gas to Heater.....	22
<b>General Installation Information .....</b>	<b>9</b>	Match Lighting Instructions .....	23
Codes .....	9	<b>Cleaning and Servicing.....</b>	<b>23</b>
Adequate Combustion and Ventilation Air ....	9	<b>Replacement Parts List.....</b>	<b>24</b>
<b>Clearances / Height Requirements .....</b>	<b>11</b>	VF20 Logs and Burner Assembly.....	24
<b>Removing Unit from Crate .....</b>	<b>13</b>	VF30 Burner Assembly .....	26
<b>Connecting the Gas.....</b>	<b>14</b>	VFCS 30 Logs.....	28
<b>Checking Gas Pressure .....</b>	<b>15</b>	<b>Troubleshooting .....</b>	<b>29</b>
<b>Connecting Remote Receiver.....</b>	<b>15</b>	<b>Warranty .....</b>	<b>Back Cover</b>
<b>Electrical Wiring .....</b>	<b>16</b>		
Connecting Optional Wall Switch or Checking			
System Operation .....	16		
<b>Log Placement.....</b>	<b>17</b>		
Installing Logs on Grate.....	18		

## IMPORTANT SAFETY INFORMATION

### INSTALLER

Please leave these instructions with the appliance.

### OWNER

Please retain these instructions for future reference.

### IMPORTANT

Read these instructions carefully before installing or trying to operate this vent-free gas heater.

### WARNING

- **Any change to this heater or its controls can be dangerous.**
- **Improper installation or use of the heater can cause serious injury or death from fire, burns, explosion or carbon monoxide poisoning.**
- **Do not allow fans to blow directly into the stove. Avoid any drafts that alter burner flame patterns.**
- **Do not use a blower insert, heat exchanger insert or other accessory, not approved for use with this heater where applicable.**

1. Due to high temperatures, the appliance should be located out of traffic and away from furniture and draperies.
2. Children and adults should be alerted to the hazard of high surface temperature and should stay away to avoid burns or clothing ignition.
3. Young children should be carefully supervised when they are in the same room with the appliance.
4. Do not place clothing or other flammable material on or near the appliance.
5. Any safety screen or guard removed for servicing an appliance, must be replaced prior to operating the heater.
6. Installation and repair should be done by a qualified service person.
7. To prevent malfunction and/or sooting, an unvented gas heater should be cleaned before use and at least annually by a professional service person. More frequent cleaning may be required due to excessive lint from carpeting, bedding material, etc. It is imperative that control compartments, burners and circulating air passageways be kept clean.

8. **CARBON MONOXIDE POISONING:** Early signs of carbon monoxide poisoning are similar to the flu with headaches, dizziness and/or nausea. If you have these signs, obtain fresh air immediately. Have the heater serviced as it may not be operating properly.
9. The installation must conform with local codes or, in the absence of local codes, with the **National Fuel Gas Code, ANSI Z223.1/NFPA54.**
10. This unit complies with ANSI Z21.11.2-2001 Unvented Heaters.
11. Do not install heater in a bathroom or bedroom unless approved for bedroom use.
12. Correct installation of the ceramic fiber logs, proper location of the heater, and annual cleaning are necessary to avoid potential problems with sooting. Sooting, resulting from improper installation or operation, can settle on surfaces outside the fireplace. See log placement instructions for proper installation.
13. Avoid any drafts that alter burner flame patterns. Do not allow fans to blow directly into fireplace. Do not place a blower inside burn area of firebox. Ceiling fans may create drafts that alter burner flame patterns. Sooting and improper burning will occur.

*Continued on page 4*

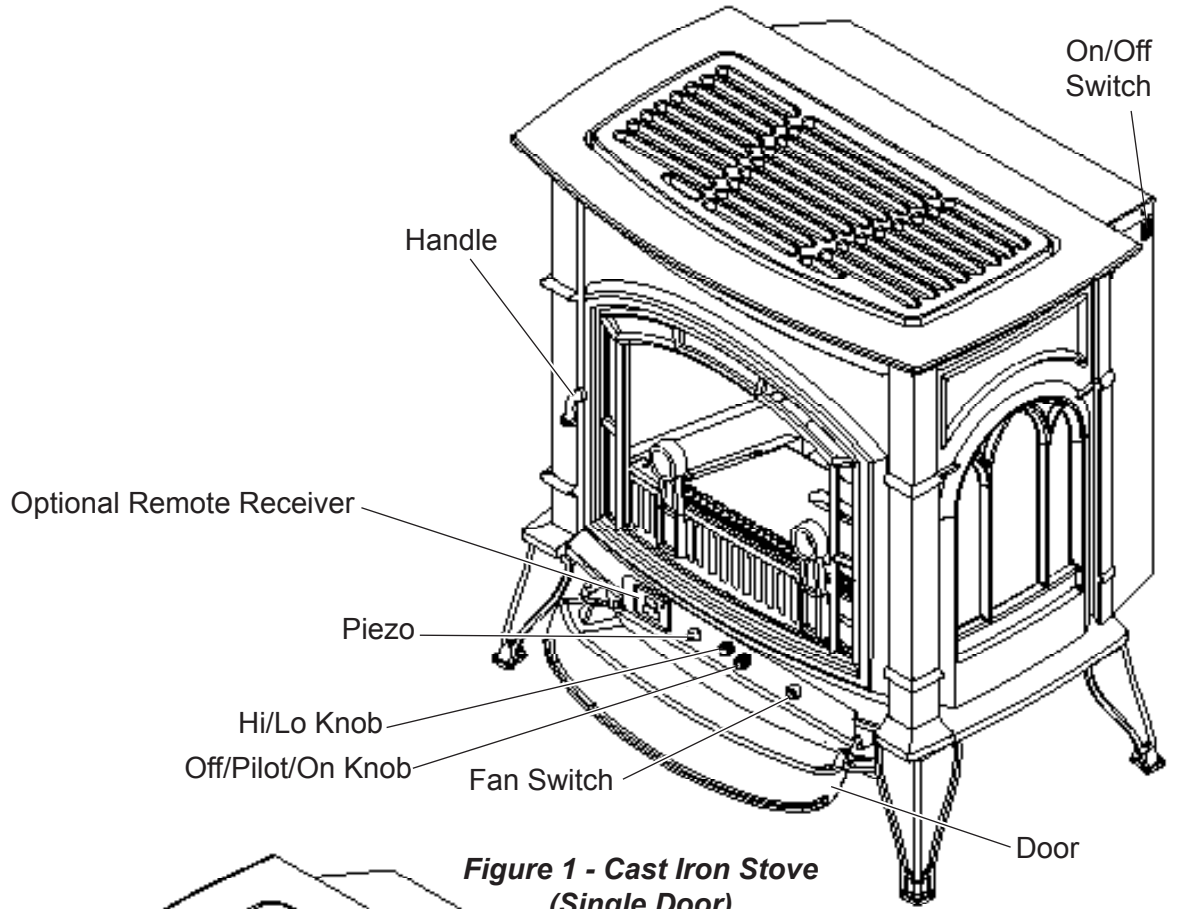
---

## IMPORTANT SAFETY INFORMATION

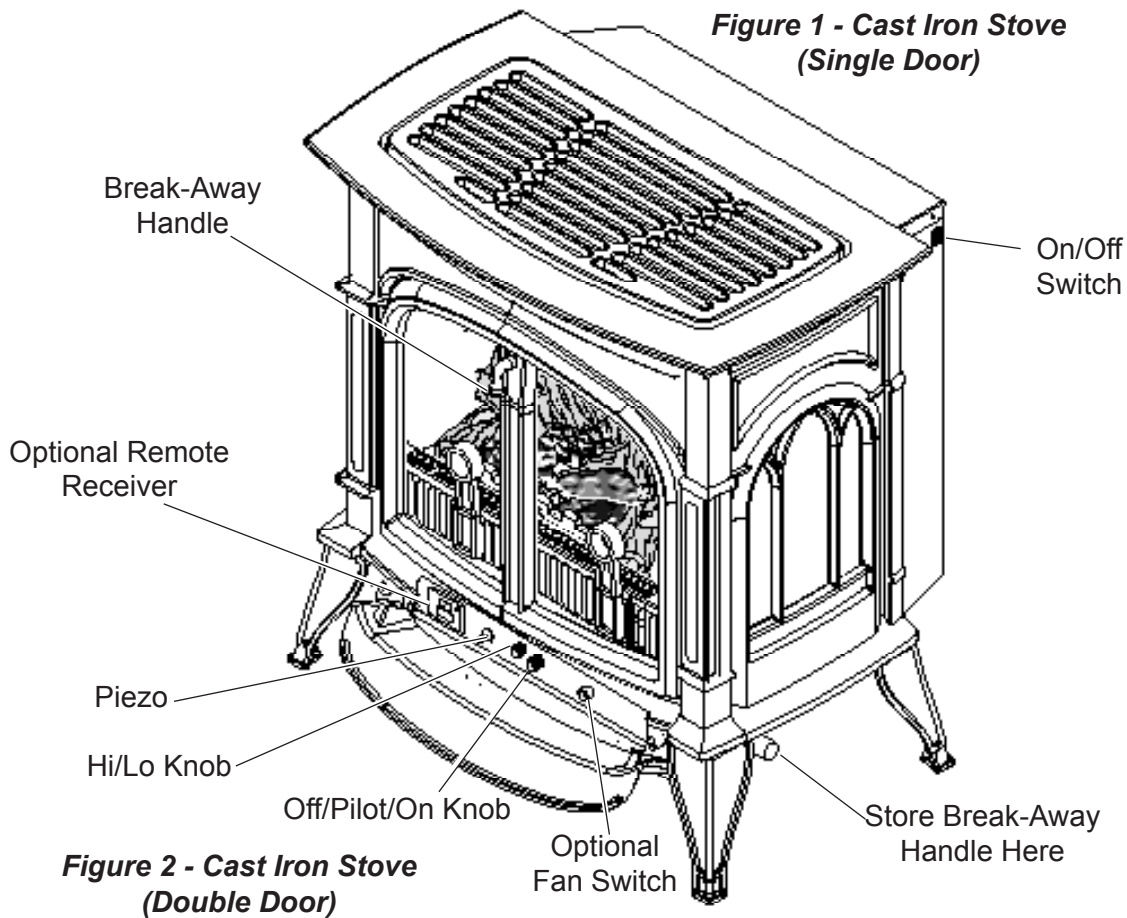
---

Continued from page 3

14. **Caution:** Candles, incense, oil lamps, etc. produce combustion by-products including soot. Vent-free appliances will not filter or clean soot produced by these types of products. In addition, the smoke and/or aromatics (scents) may be reburnt in the vent-free appliance which can produce odors. It is recommended to minimize the use of candles, incense, etc. while the vent-free appliance is in operation.
15. This is an unvented gas-fired heater. It uses air (oxygen) from the room in which it is installed. Provisions for adequate combustion and ventilation air must be provided. *See page 8.*
16. Keep room area clear and free from combustible materials, gasoline and other flammable vapors and liquids.
17. Unvented gas heaters are a supplemental zone heater. They are not intended to be a primary heating appliance.
18. Unvented gas heaters emit moisture into the living area. In most homes of average construction, this does not pose a problem. In houses of extremely tight construction, additional mechanical ventilation is recommended.
19. During manufacturing, fabricating and shipping, various components of this appliance are treated with certain oils, films or bonding agents. These chemicals are not harmful but may produce annoying smoke and smells as they are burned off during the initial operation of the appliance; possibly causing headaches or eye or lung irritation. This is a normal and temporary occurrence.
20. The initial break-in operation should last two to three hours with the burner at the highest setting. Provide maximum ventilation by opening windows or doors to allow odors to dissipate. Any odors remaining after this initial break-in period will be slight and will disappear with continued use.
20. Input ratings are shown in BTU per hour and are for elevations up to 2,000 feet. For elevations above 2,000 feet, input ratings should be reduced 4 percent for each 1,000 feet above sea level. Refer to the National Fuel Gas Code.
21. The appliance and its appliance main gas valve must be disconnected from the gas supply piping system during any pressure testing of that system at test pressures in excess of 1/2 psig (3.5 kPa).
22. The appliance must be isolated from the gas supply piping system by closing its equipment shutoff valve during any pressure testing of the gas supply piping system at test pressures equal to or less than 1/2 psig (3.5 kPa).
23. Do not use this room heater if any part has been under water. Immediately call a qualified service technician to inspect the room heater and to replace any part of the control system and any gas control which has been under water.
24. Never burn solid fuels in an unvented room heater, fireplace or stove.
25. Do not set kettles or humidifying devices on top of stove.
26. The stove door/screen must be closed when the appliance is operating. The screen shall have openings for induction of combustion air.

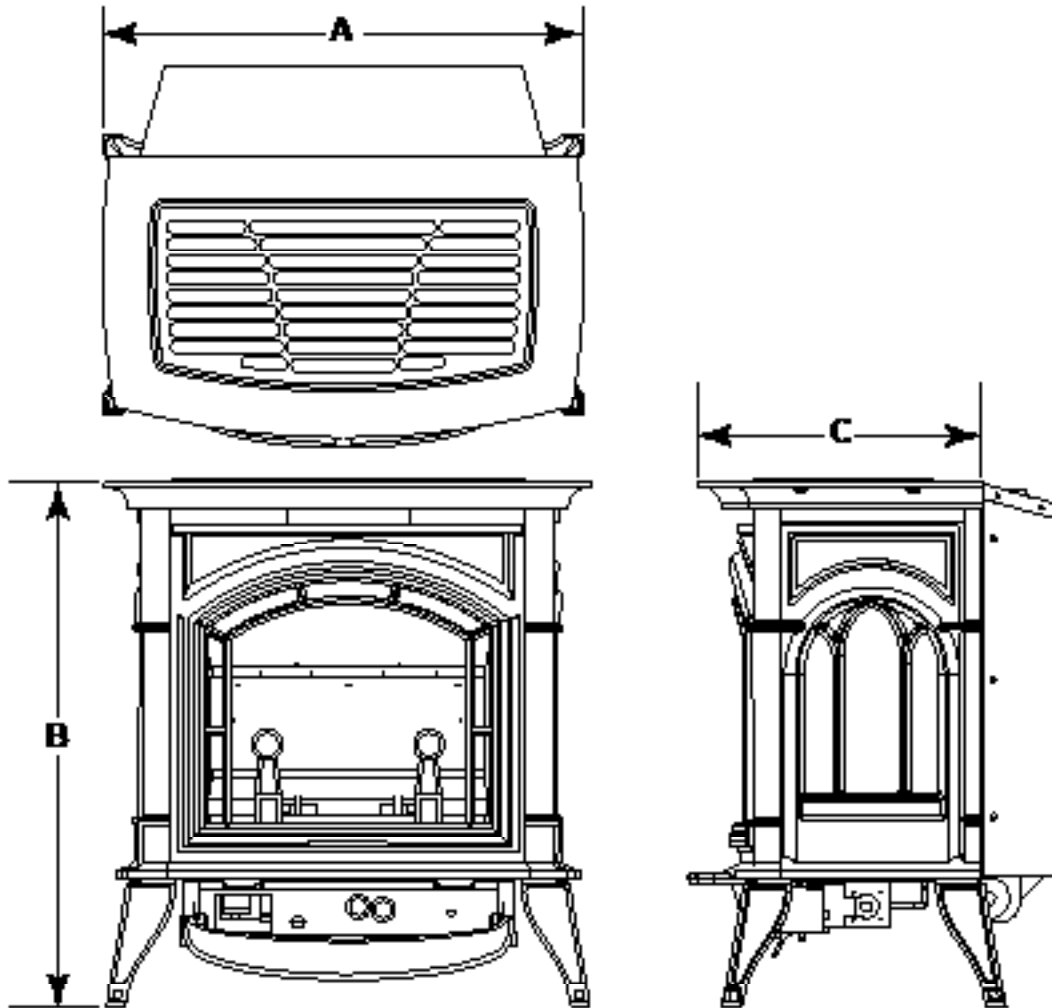


**Figure 1 - Cast Iron Stove  
(Single Door)**



**Figure 2 - Cast Iron Stove  
(Double Door)**

# DIMENSIONS



*Figure 3 - Dimensions*

	CSVF20S/VFCS20D	CSVF30S/VFCS30D
<b>A</b>	21 <sup>1</sup> / <sub>4</sub> "	26 <sup>3</sup> / <sub>4</sub> "
<b>B</b>	23"	28 <sup>1</sup> / <sub>2</sub> "
<b>C</b>	16 <sup>1</sup> / <sub>2</sub> "	19 <sup>3</sup> / <sub>4</sub> "

### MAKE SURE YOU HAVE RECEIVED ALL PARTS:

Check your packing list to verify that all listed parts have been received. You should have the following:

- Cast Iron Stove with Burner Assembly
- Installation/Operating Instructions
- Ceramic Fiber Logs
- Touch-up Paint

Millivolt controlled heater designed to be operated with optional devices for ON/OFF functions.

- Hand-Held Remote with Manual Receiver
- Wall Switch with 15' Wire

**CAUTION**

**Gloves are recommended when handling ceramic fiber logs to prevent skin irritation from loose fibers. Logs are fragile — handle with care.**

Carefully inspect the contents for shipping damage. If any parts are missing or damaged, immediately inform the dealer from whom you purchased the appliance. **Do not attempt to install any part of the appliance unless you have all parts in good condition.**

### WHAT YOU WILL NEED FOR INSTALLATION:

You must have the following items available before proceeding with installation:

- External regulator (for propane/L.P.G.) or high pressure natural gas (1 to 2 PSI system)
- Piping which complies with local codes
- Sediment trap (recommended)
- Pipe wrench or appropriate wrench set
- Pipe sealant approved for use with propane/L.P.G. (Resistant to sulfur compounds)
- Manual shutoff valve
- Tee joint
- Screwdrivers

---

## PRODUCT SPECIFICATIONS

---

### NATURAL GAS

**NOTE:** An external regulator is required to reduce supply pressure to a maximum of 10<sup>1</sup>/<sub>2</sub>" w.c. on Natural Gas systems operating at higher pressure.

#### MILLIVOLT PRESSURE

Regulator Pressure Setting: 3.5" w.c.

Pilot Regulator: 3.5" w.c.

Gas Inlet Pressure: Max. 10 1/2" w. c. Min. 5" w.c.

Model Number	Type	Gas Rate	
		Max. BTU/Hr	Min. BTU/Hr
CSVF20SNV/FCFS20DNV (G-EBL-ES-EMB)	Millivolt	10,000	6,000
CSVF30SNV/FCFS30DNV (G-EBL-ES-EMB)	Millivolt	32,000	20,000

### PROPANE / LPG

**Note:** An external regulator is required to reduce supply pressure to a maximum of 13" w.c.

#### MILLIVOLT PRESSURE

Regulator Pressure Setting: 10" w.c.

Gas Inlet Pressure: Maximum 13" w.c.  
Minimum 11" w.c.

Model Number	Type	Gas Rate	
		Max. BTU/Hr	Min. BTU/Hr
CSVF20SPV/FCFS20DPV (G-EBL-ES-EMB)	Millivolt	10,000	6,000
CSVF30SPV/FCFS30DPV (G-EBL-ES-EMB)	Millivolt	32,000	20,000

### IGNITION CONTROLS

Piezo ignitor allows ignition of the pilot without the use of matches.

**Millivolt control has four (4) positions:**

- OFF** - All gas to the burner is shut off at the valve.
- IGN** - Valve position to light/maintain a standing pilot.
- ON** - Valve position to turn burners ON/OFF with remote switch.
- LOW/HI** - Variable position to control flame height (heat output). Both front and rear burners are in operation to provide realistic glow and yellow flame.

### PILOT/ODS

The gas log heater is fitted with a specially designed safety pilot (ODS assembly) light which senses the amount of oxygen available in the room and shuts the gas log heater off if the oxygen level begins to drop below a satisfactory level. The pilot can only be relit when adequate fresh air is available.

### THERMAL GENERATOR

The millivolt gas log pilot is fitted with a millivolt thermopile generator to provide power for remote activation.



- WARNING**
- Do not install the heater ...**
- **Where curtains, furniture, clothing, or other flammable objects are less than 42" from the front of the heater.**
  - **In high traffic areas.**
  - **In windy or drafty areas.**

### CODES

Adhere to all local codes or, in their absence, the latest edition of THE NATIONAL FUEL GAS CODE ANSI Z223.1 or NFPA54 which can be obtained from...

**American National Standards Institute, Inc.**

1430 Broadway  
New York, NY 10018

or

**National Fire Protection Association, Inc.**

Batterymarch Park  
Quincy, MA 02269

### ADEQUATE COMBUSTION AND VENTILATION AIR

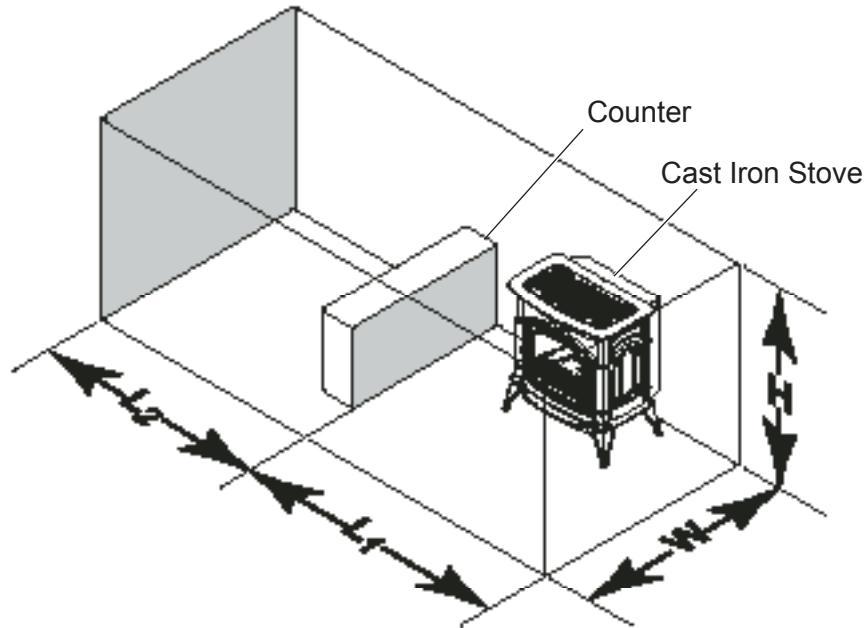
This heater shall not be installed in a confined space or unusually tight construction unless provisions are provided for adequate combustion and ventilation air.

**The National Fuel Gas Code, (ANSI Z223.1/NFPA54)**, defines a confined space as a space whose volume is less than 50 cubic feet per 1,000 BTU per hour (4.8 m<sup>3</sup> per kw) of the aggregate input rating of all appliances installed in that space and an unconfined space as a space whose volume is not less than 50 cubic feet per 1,000 BTU per hour (4.8 m<sup>3</sup> per kw) of the aggregate input rating of all appliances installed in that space. Rooms communicating directly with the space in which the appliances are installed, through openings not furnished with doors, are considered a part of the unconfined space.

### UNUSUALLY TIGHT CONSTRUCTION IS DEFINED AS CONSTRUCTION WHERE...

- a) walls and ceilings exposed to the outside atmosphere have a continuous water vapor retarder with a rating of 1 perm ( $6 \times 10^{11}$  kg per pa-sec-m<sup>2</sup>) or less with openings gasketed or sealed;
- b) weather stripping has been added on openable windows and doors, and
- c) caulking or sealants are applied to areas such as joints around window and door frames, between sole plates and floors, between wall-ceiling joints, between wall panels, at penetrations for plumbing, electrical, and gas lines, and at other openings.

## GENERAL INSTALLATION INFORMATION



**Figure 4 - Example of a Large Room with 1/2 Wall Divider**

The following formula can be used to determine the maximum heater rating per the definition of unconfined space:

$$\text{BTU/Hr} = \frac{(L_1 + L_2) \text{ Ft} \times (W) \text{ Ft} \times (H) \text{ Ft}}{50} \times 1000$$

Consider two connecting rooms with an open area between, with the following dimensions:

$$L_1 = 15\frac{1}{2} \text{ Ft.}, L_2 = 12 \text{ Ft.}, W = 12 \text{ Ft.}, H = 8 \text{ Ft.}$$

$$\text{BTU/Hr} = \frac{(15\frac{1}{2} + 12) \times (12) \times (8)}{50} \times 1000 = 52800 \text{ BTU/Hr}$$

If there were a door between the two rooms the calculation would be based only on the room with the heater.

$$\text{BTU/Hr} = \frac{(15\frac{1}{2}) \times (12) \times (8)}{50} \times 1000 = 29760 \text{ BTU/Hr}$$

### WARNING

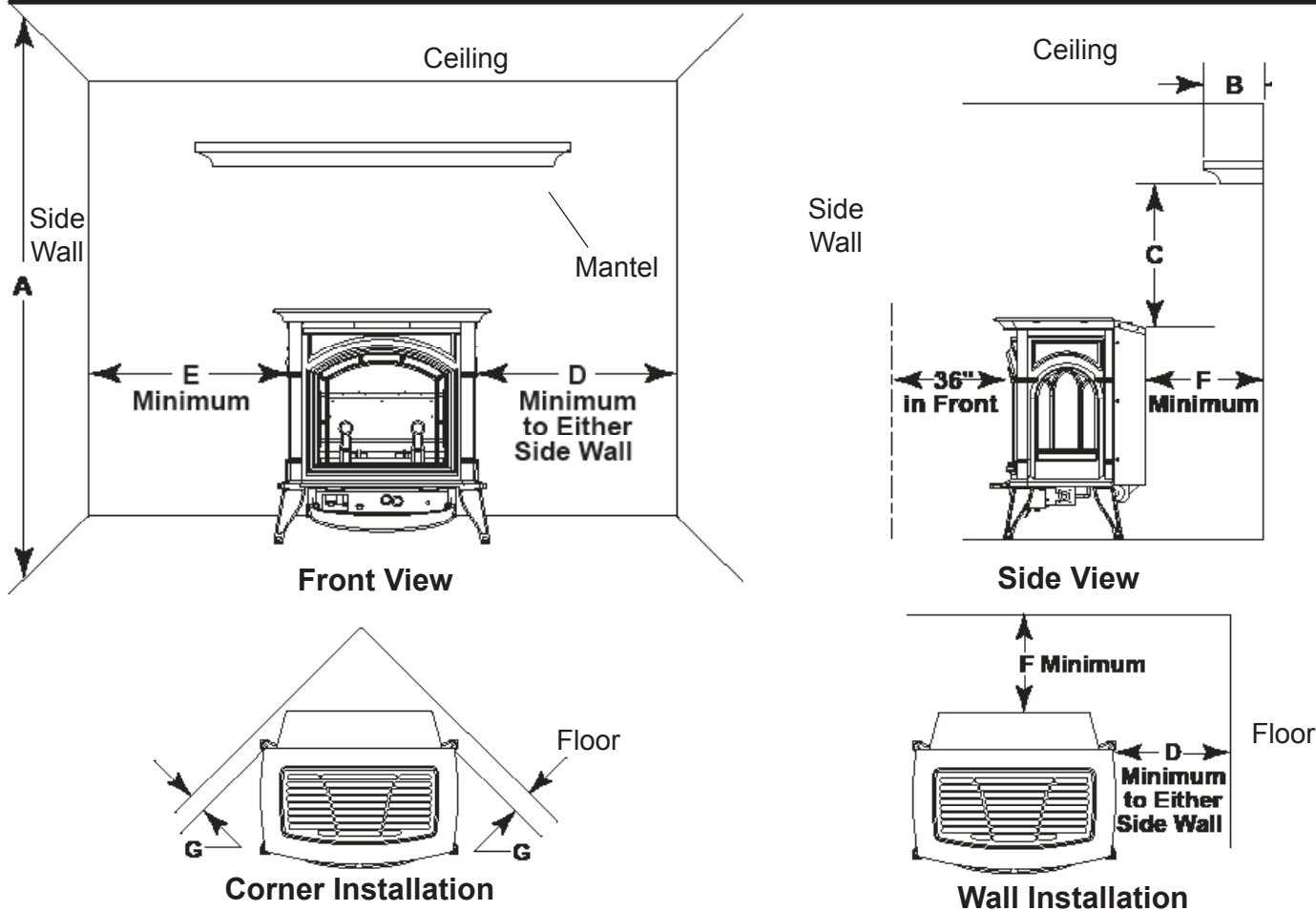
If the area in which the heater may be operated is smaller than that defined as an unconfined space or if the building is of unusually tight construction, provide adequate combustion and ventilation air by one of the methods described in the National Fuel Gas Code, ANSI Z223.1, NFPA54, Section 5.3 or applicable local codes.

## CLEARANCES / HEIGHT REQUIREMENTS

**WARNING**

The dimensions shown in *Figure 5* are minimum clearances to maintain in installing this heater. Left and right clearances are determined when facing the front of the heater. Follow these instructions carefully to ensure safe installation. Failure to follow instructions exactly can create a fire hazard.

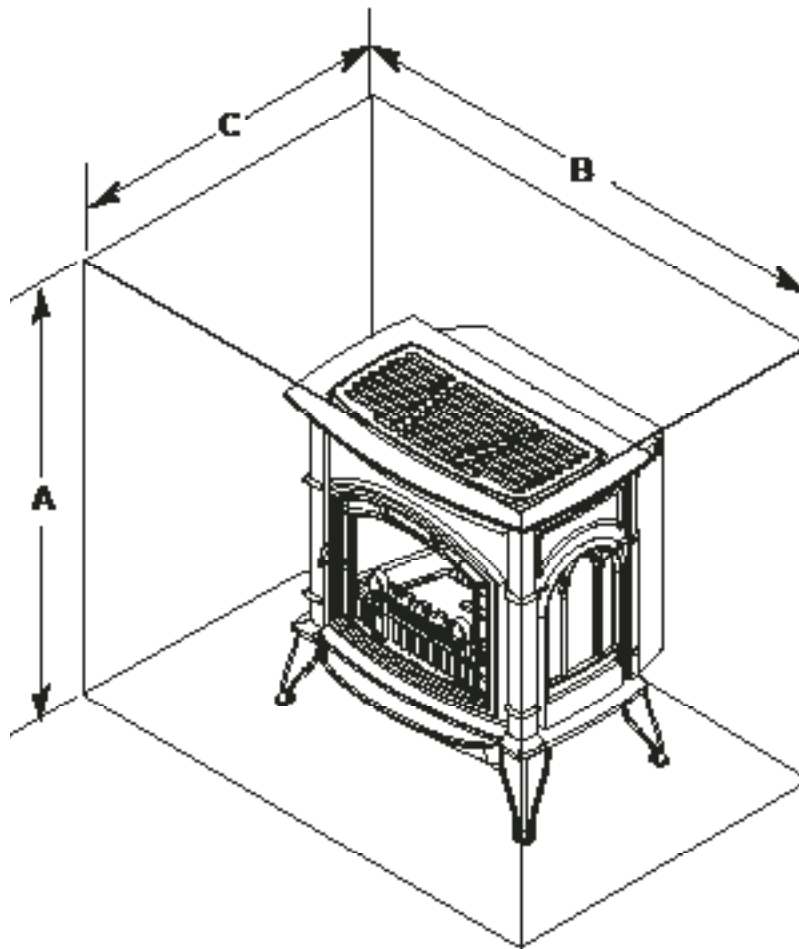
The appliance cannot be installed on a carpet, tile or other combustible material other than wood flooring, the appliance shall be installed on a metal, wood or noncombustible material panel extending full width and depth of the appliance.



**Figure 5 - Minimum Clearance to Walls and Ceiling**

Product	Min. Ceiling from Floor A	Mantel Clearance from Top of Unit		Side, Measured from Top		Rear Measured from Back F	Corner Measured From Top Corners G
		Max. Protrusion B	Min. Height C	Right D	Left E		
VF20	72"	12"	16"	1"	1"	□"	1□"
VF30	72"	12"	18"	2"	2"	1"	□"

## CLEARANCES / HEIGHT REQUIREMENTS



*Figure 6 - Placing Stove in Alcove*

### Tested Minimum Alcove Dimensions

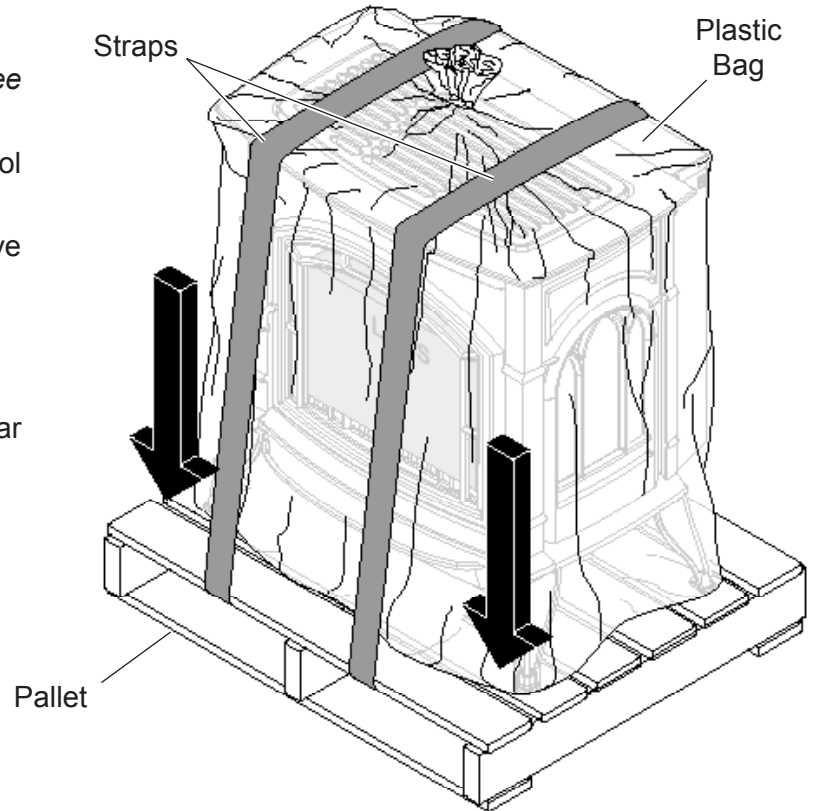
	Height From Hearth A	Width B	Depth C
<b>VF20</b>	38" □	23"	36"
<b>VF30</b>	52"	34"	36"

*Note: Maintain minimum side and back clearances when placing stove in alcove.*

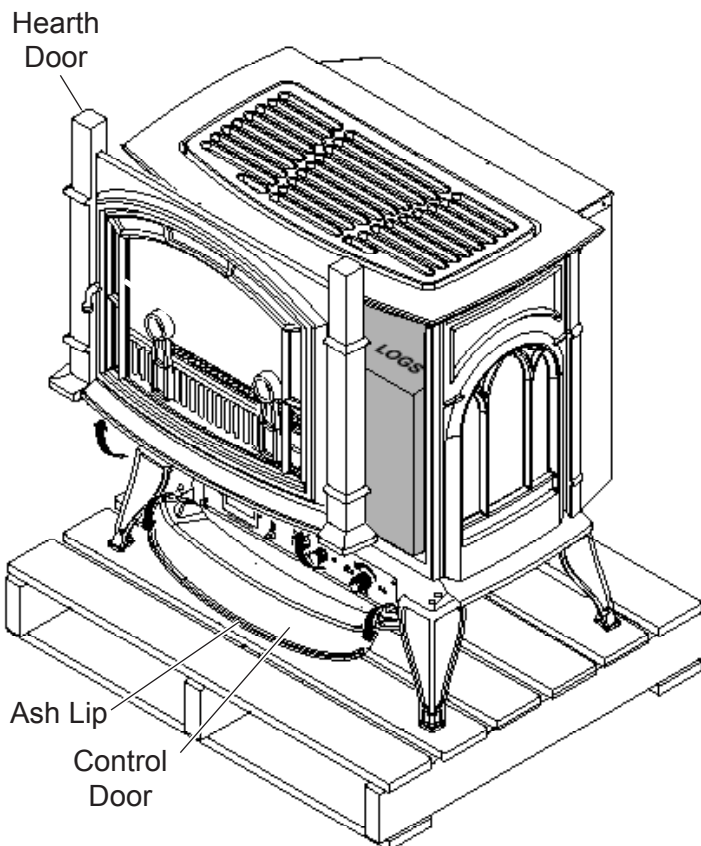
## REMOVING UNIT FROM CRATE

1. Remove two (2) straps. See *Figure 7*.
2. Open plastic bag and slide to bottom of unit. See *Figure 8*.
3. Lift up on ash lip and pivot down to open control door. See *Figure 9*.
4. Lift up on front. Pivot bottom of front out. Remove front. See *Figure 9*.
5. Lift screen to remove.
6. Remove log box from inside of unit.
7. Lift unit off pallet. Lift unit up high enough to clear upright supports unit is sitting on.

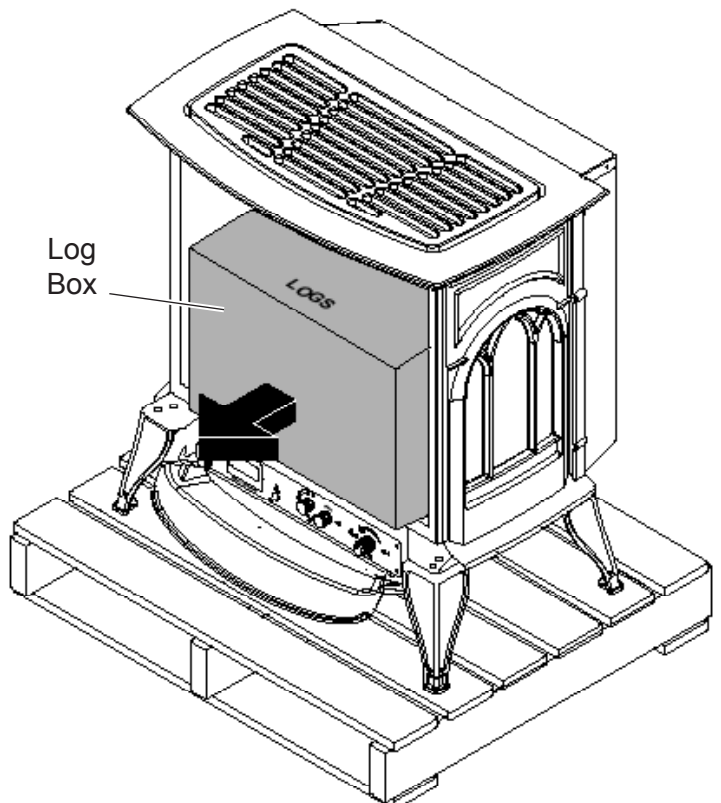
**Note: You will need at least two (2) strong people to lift unit off of pallet.**



**Figure 7 - Removing Straps and Plastic from Unit**



**Figure 8 - Opening Control Door and Removing Hearth Door**



**Figure 9 - Removing Log Box**

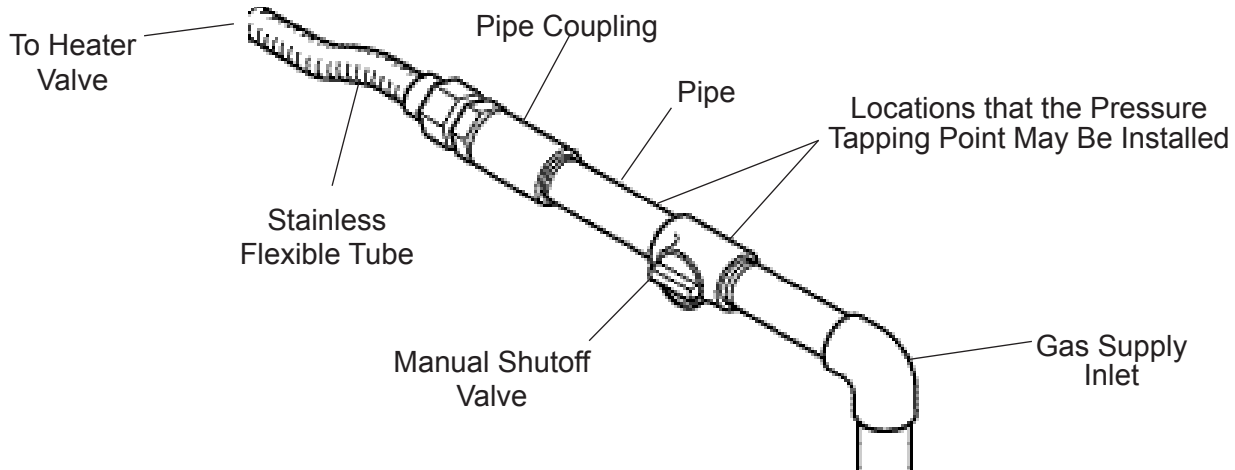
## CONNECTING THE GAS

**NOTICE:** A qualified gas appliance installer must connect the heater to the gas supply. Consult all local codes.

**CAUTION**

Use new black iron or steel pipe. Internally tinned copper or copper tubing can be used per National Fuel Code, section 2.6.3, providing gas meets hydrogen sulfide limits, and where permitted by local codes. Gas piping system must be sized to provide minimum inlet pressure (Listed on Data Plate) at the maximum flow rate (BTU/Hr). Undue pressure loss will occur if the pipe is too small.

A manual shutoff valve must be installed upstream of the appliance. Union tee and plugged 1/8" NPT pressure tapping point should be installed upstream of the appliance. See *Figure 10*.



*Figure 10 - Gas Connection*

**IMPORTANT:** Hold heater valve firmly with a wrench to prevent movement when connecting to inlet pipe.

**CAUTION**

**CHECK GAS TYPE:** The gas supply must be the same as stated on the heater's rating plate. If the gas supply is different, **DO NOT INSTALL THE HEATER**. Contact your dealer for the correct model.

Always use an external regulator for all propane/LPG heaters and high pressure one to two-pound systems only, to reduce the supply tank pressure to a maximum of 13" w.c. This is in addition to the internal regulator in the heater valve.

## CHECKING GAS PRESSURE AND CONNECTING REMOTE RECEIVER

The heater gas inlet connection is 3/8" NPT at the valve. The inlet is located on left side of stove. Remove front control plate to better access the inlet.

When tightening up the joint to the valve, hold the valve securely with a wrench to prevent movement.

Test all gas joints from the gas meter to the heater valve for leaks using a gas analyzer or soap and water solution after completing connection. **DO NOT USE AN OPEN FLAME.**

Check the gas pressure with the appliance burning and the control set to **HIGH**.

### MILLIVOLT CONTROL (FIGURE 11)

The valve regulator controls the burner pressure which should be checked at the pressure test point.

If outlet pressure is low, check inlet pressure against data plates or manual.

Turn captured slotted screw counter clockwise 2 or 3 turns and then place tubing to pressure gauge over test point (Use test point "OUT" closest to control knob). After taking pressure reading, be sure and turn captured screw clockwise firmly to re-seal. Do not over torque. Check for gas leaks.

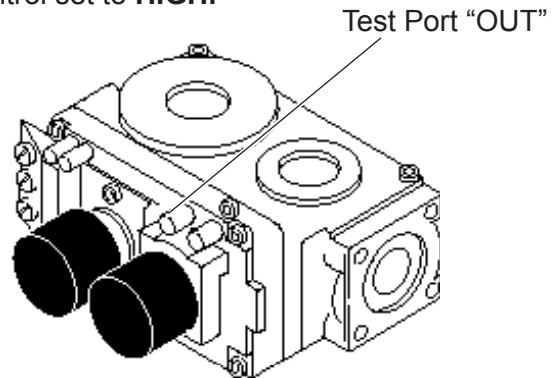
**NOTE: Remove control panel to access gas valve.**

### CONNECTING REMOTE RECEIVER

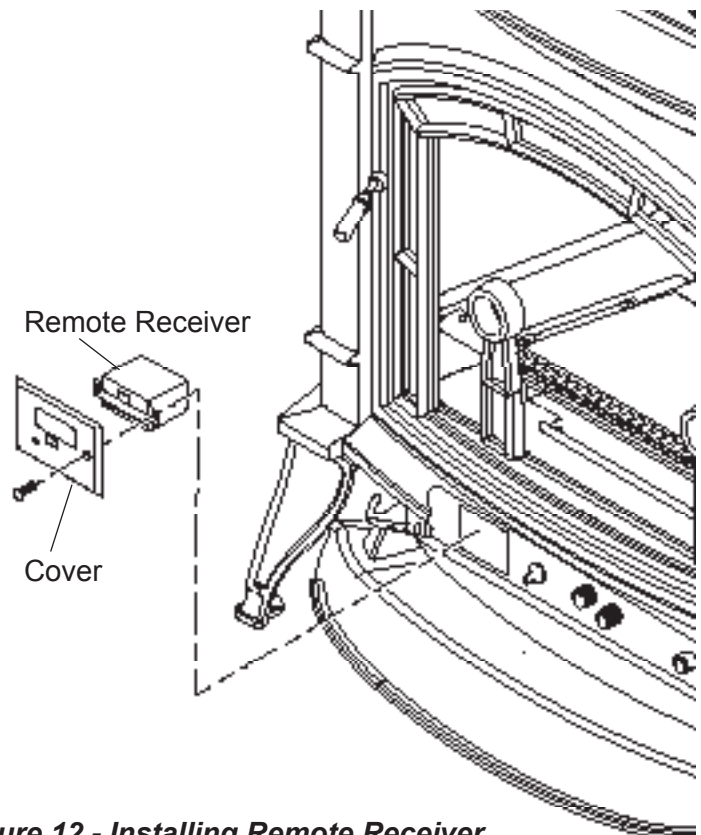
1. Remove cover on control panel to show opening for remote receiver. See Figure 12.
2. Follow remote receiver Instructions to make all necessary wiring connections.
3. Place remote receiver in the opening of control panel. Use two screws provided to attach remote receiver to the control panel. See Figure 12.

**NOTE: Do not place remote in combustion chamber.**

**WARNING**  
Connecting directly to an unregulated propane/L.P.G. tank can cause an explosion.



**Figure 11 - Pressure Test Point Location  
Millivolt Control**



**Figure 12 - Installing Remote Receiver**

## ELECTRICAL WIRING (MILLIVOLT)

The millivolt valve is a self-powered combination gas control **THAT DOES NOT REQUIRE 110 VAC TO OPERATE.**

**CAUTION**  
**Label all wires prior to disconnection when servicing controls. Wiring errors can cause improper and dangerous operation. Verify proper operation after servicing.**

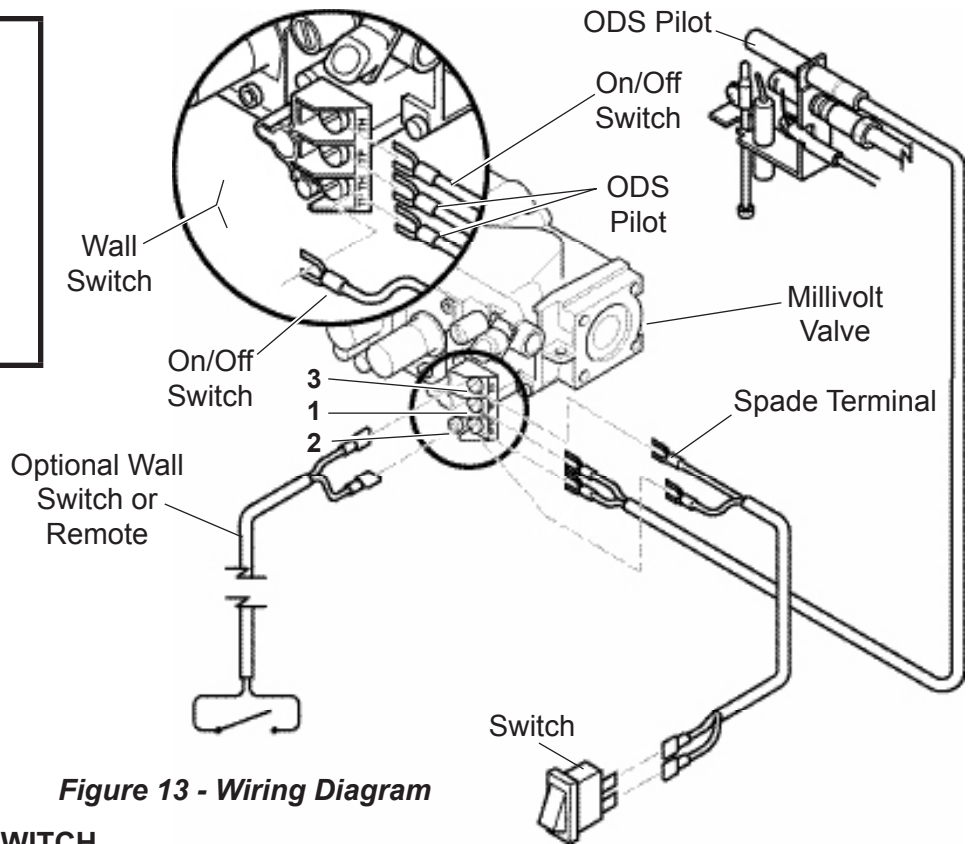


Figure 13 - Wiring Diagram

- CONNECTION**  
 1 = TP  
 2 = TP, TH  
 3 = TH

### CONNECTING OPTIONAL WALL SWITCH

1. Use 18 awg, two-wire cable, 15 feet maximum length.
2. At one end of the cable, connect both wires to the wall switch. At the other end, connect one wire to TP/TH and one wire to TH, or connect the wall switch to the two male (0.25") terminals on the left side of the unit. The color of the wires does not matter.

### CHECKING SYSTEM OPERATION

The millivolt system and individual components may be checked with a millivolt meter having a 0-1000mv range. Conduct each check shown in chart by connecting meter test leads to terminals as indicated.

CHECK TEST	TO TEST	CONNECT METER LEADS TO TERMINALS	METER READING SHOULD BE
A	COMPLETE	2 & 3 SYSTEM	MINIMUM 175mv
B	THERMOPILE OUTPUT	1 & 2 SYSTEM	500mv OR MORE

#### A. COMPLETE MILLIVOLT SYSTEM CHECK

("A" Reading - On/Off switch contacts **CLOSED** - Control Knob "ON" - Main Burners should turn ON)

- a. If the reading is more than 175 millivolts and the automatic valve still does not come on - replace the valve.
- b. If the closed circuit reading ("A" reading) is less than 175 millivolts, determine cause for low reading - proceed as follows:

#### B. THERMOPILE OUTPUT READING CHECK

("B" Reading - On/Off switch contacts **OPEN** - Main burner OFF)

Check gas pressure to the unit. If gas pressure is within minimum and maximum on data plate, then replace pilot. If the minimum millivolt reading is not obtainable, replace pilot.



**Before you begin** — This unit is supplied with four ceramic fiber logs. Do not handle these logs with your bare hands. **Always wear gloves to prevent skin irritation from ceramic fibers.** After handling the logs, wash your hands gently with soap and water to remove any traces of fibers.

## WARNING

The positioning of the logs are critical to the safe and clean operation of this heater. Sooting and other problems may result if the logs are not properly and firmly positioned in the appliance. Never add additional logs or embellishments such as pine cones, vermiculite or rock wool to the heater. Only use the logs supplied with the unit.

Failure to position the parts in accordance with diagrams below or to use only parts specifically approved for this heater may result in property damage or personal injury.

### VF30 INSTALLING LOGS ON GRATE

(See Figure 14)

1. Install back log (#1) on rear log support bracket.
2. Install left bottom log (#2) on left log support bracket in front of back log.
3. Install right bottom log (#3) on right log support bracket in front of back log.
4. Install top left log (#4) on top of left bottom log.
5. Install top right log (#5) on top of right bottom log.

## CAUTION

During initial operation of the new heater, burning logs will give off a paper burning smell and orange flames will be present. Simply open the windows for a few hours to vent the odor.

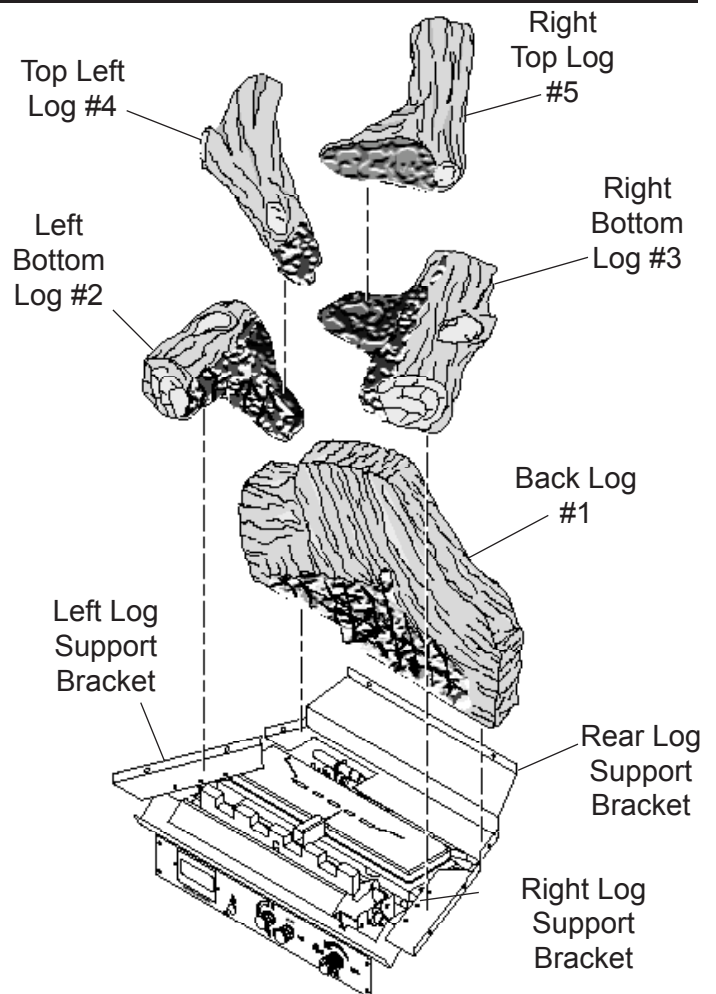


Figure 14 - Installing Logs to Grate (VF30)

## LOG PLACEMENT

### VF20 INSTALLING LOGS ON GRATE

(See Figure 15)

1. Install back log (#1) on back of burner assembly.
2. Install front log (#2) on 2 pegs on burner assembly.

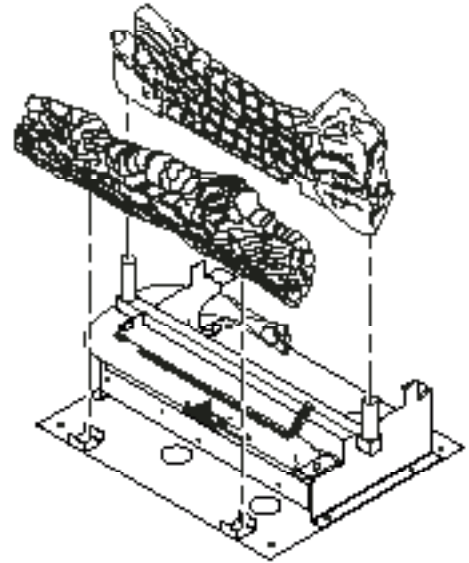



Figure 15 - Installing Logs to Grate (VF20)

## ROCK WOOL INSTALLATION (VF30 UNITS ONLY)

1. Break rock wool into dime-sized pieces. → 
2. Place rock evenly across rock wool tray and front burner as shown in Figure 16.

- **Rock wool depth must not be more than 1".**
- **Do not place rock wool past the bend in rock wool tray.**
- **Do not place rock wool on rear burner.**

**WARNING**

Rock wool must be placed correctly. Placing rock wool in wrong area will create high carbon monoxide.

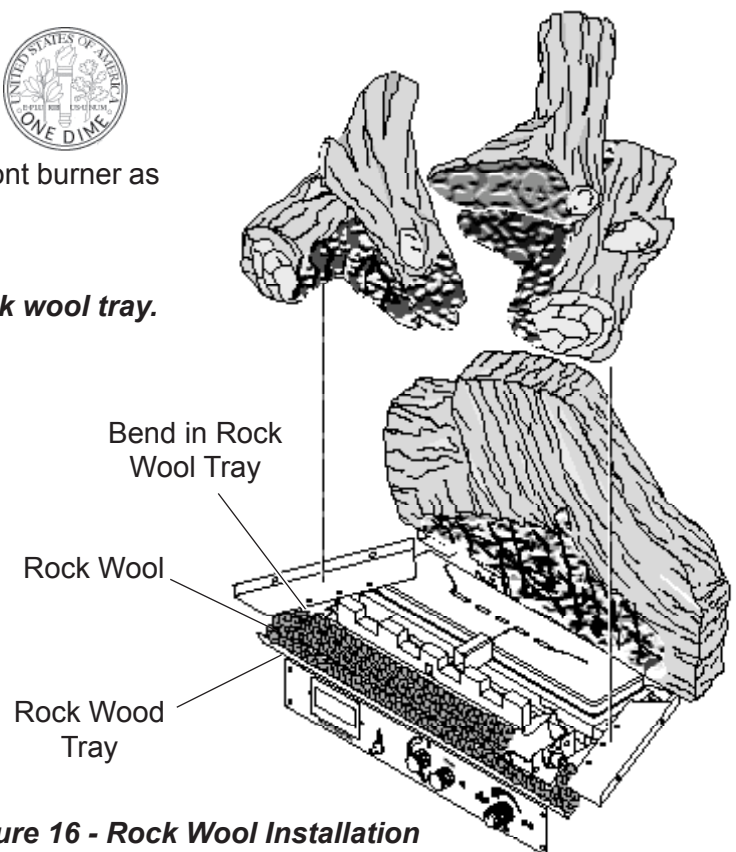


Figure 16 - Rock Wool Installation

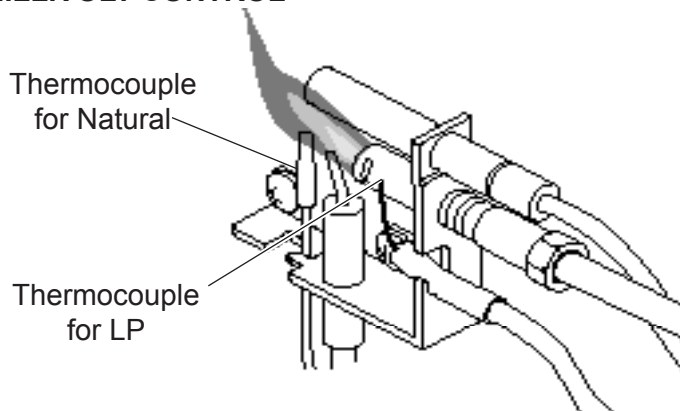
Flames from the pilot, front and rear burner should be visually checked as soon as the heater is installed. In addition, periodically check the flames visually during operation.

### CHECKING PILOT FLAME

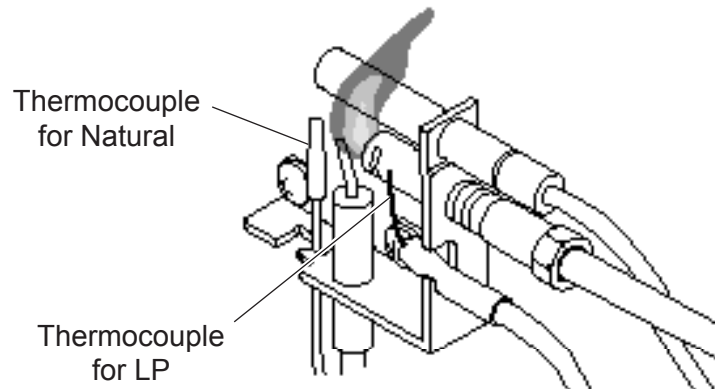
The pilot flame must always be present when the heater is in operation. It should just touch the top of the thermocouple tip for natural. See *Figure 17* for correct pilot flame.

If the pilot flame does not touch the thermocouple, then the burners cannot function reliably. See *Figure 18* for incorrect shape of pilot flame.

### MILLIVOLT CONTROL



**Figure 17 - Correct Appearance of Pilot Flame**



**Figure 18 - Incorrect Appearance of Pilot Flame**

---

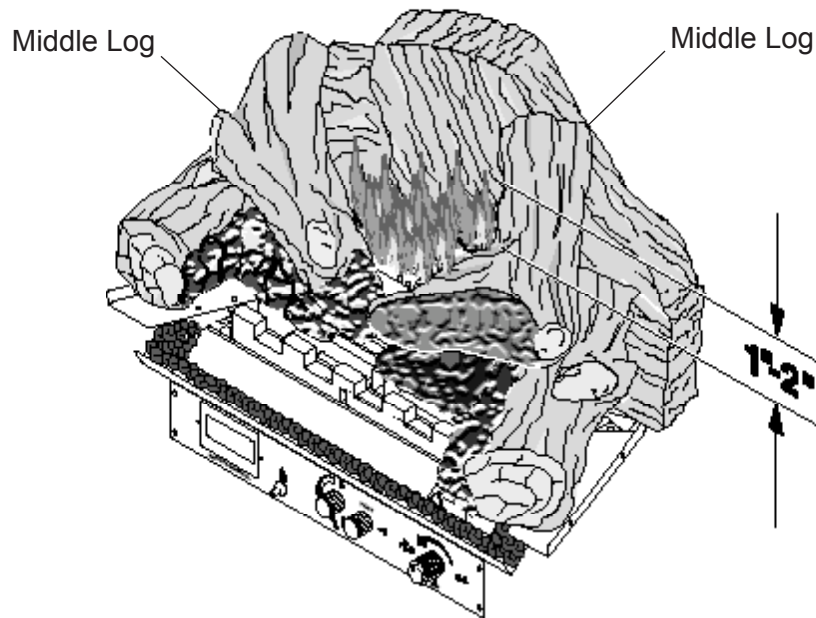
## FLAME APPEARANCE

---

### CHECKING BURNER FLAME

In normal operation at full rate after 15 minutes, the following flame appearances should be observed:

The left and right rear flames should be yellow and extend 1"-2" above middle logs. The yellow flames should *not* contact the logs. There should be glowing embers on the front surface of the middle log. **Note: The flames and embers will be an opaque orange color during the burn off time.**



**Figure 19 - Correct Flame Appearance**

### OPERATING INSTRUCTIONS

**Avoid any drafts that alter burner flame patterns.** Do not allow fans to blow directly into the stove. Do not place a blower inside the burn area of the stove. Ceiling fans may create drafts that alter flame patterns. Sooting and improper burning will result.

During manufacturing, fabricating and shipping, various components of this appliance are treated with certain oils, films or bonding agents. These chemicals are not harmful, but may produce annoying smoke and smells as they are burned off during the initial operation of the appliance, possibly causing headaches or eye or lung irritation. *This is a normal and temporary occurrence.*

The initial break-in operation should last two to three hours with the burner at the highest setting. Provide maximum ventilation by opening windows or doors to allow odors to dissipate. Any odors remaining after this initial break-in will be slight and will disappear with continued use.

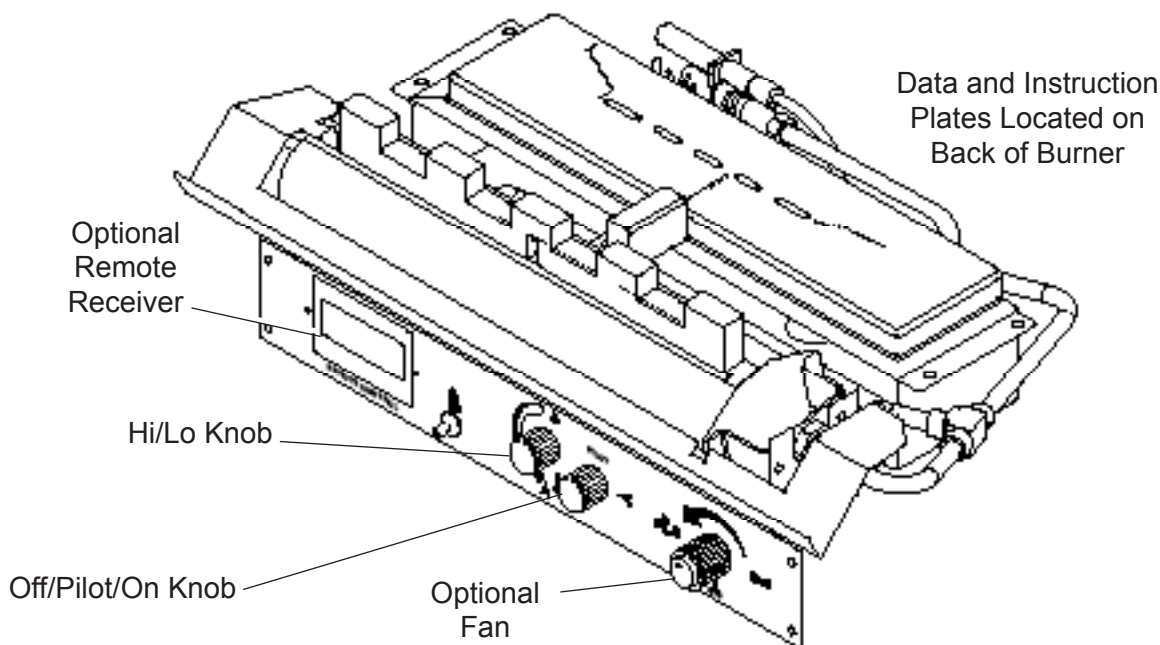
**FOR YOUR SAFETY READ BEFORE LIGHTING****WARNING**

If you do not follow these instructions exactly, a fire or explosion may result causing property damage, personal injury or loss of life.

- A.** This appliance is equipped with an ignition device which automatically lights the pilot. If the piezo is not working properly, see *Match Lighting Instructions, page 24*.
- B.** BEFORE OPERATING smell all around the appliance area for gas. Be sure to smell next to the floor because some gas is heavier than air and will settle on the floor.

**WHAT TO DO IF YOU SMELL GAS:**

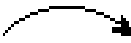
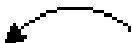

- Do not attempt to light any appliance.
  - Do not touch any electric switch; do not use any phone in your building.
  - Immediately call your gas supplier from a neighbor's phone. Follow the gas supplier's instructions.
  - If you cannot reach your gas supplier, call the fire department.
- C.** Use only your hand to push in, or turn the gas control knob. Never use tools. If the knob will not push in or turn by hand, don't try to repair it. Call a qualified service technician. Force or attempted repair may result in a fire or explosion.
- D.** Do not use this appliance if any part of it has been under water. Immediately call a qualified service technician to inspect the appliance and to replace any part of the control system and any



**Figure 20 - Location of Piezo Ignitor, Control Knobs and Switch on Millivolt Unit**

## OPERATING INSTRUCTIONS

### Millivolt CONTROL LIGHTING INSTRUCTIONS

1. STOP! Read the safety information label.
2. Make sure the manual shutoff valve is fully open.
3. This gas log set is equipped with an ignition device (piezo) which automatically lights the pilot. If piezo ignitor does not light the pilot, refer to instructions for *Match Lighting Instructions, page 23*.
4. Turn gas control knob clockwise  to the OFF position, turn ON/OFF switch to OFF position.
5. Wait (5) minutes to clear out any gas. Then smell for gas, including near the floor. If you smell gas, STOP! Follow the instructions under *What To Do If You Smell Gas, page 21*.
6. From OFF position, turn the gas control knob counterclockwise  to IGN position. Push in control knob for 5 seconds. **NOTE: If you are running the heater for the first time, it may be necessary to press in the control knob for 30 seconds or longer to allow air to bleed out of the gas piping.**
7. With the control knob pushed in, push in and release the piezo ignitor button to light the pilot.
8. Continue pushing the control knob in for a further 10 seconds to prevent the flame detector from shutting off the gas while the probe is warming up. Release the control knob.
9. Turn gas control knob counterclockwise  to the ON position.
10. After the pilot has been lit for one minute, the burners can be turned on. Turn the ON/OFF switch to ON position.
11. If the gas logs will not operate, follow the instructions "To Turn Off Gas To Heater" below and call your service technician or gas supplier.

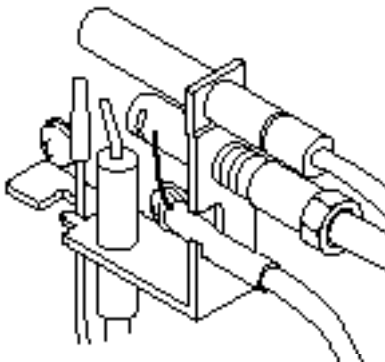


Figure 21 - Pilot

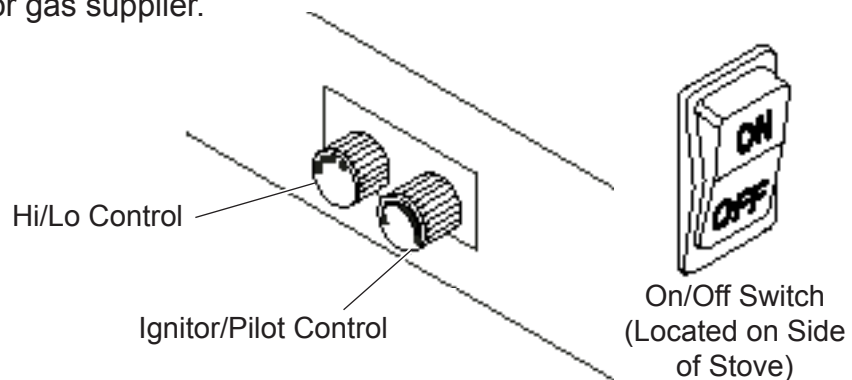



Figure 22 - Control Cover Plate for Millivolt

### TO TURN OFF GAS TO HEATER

1. Turn ON/OFF switch to OFF position.
2. Turn control knob clockwise  to OFF position to completely shut off the heater.
3. If applicable: Turn off all electric power to the heater.

**MATCH LIGHTING INSTRUCTIONS**

1. Open stove door. Remove any items necessary for easy access to the pilot (for example: logs, screens, etc.).
2. Follow appropriate lighting instructions found previously. Light a match and hold the flame to the end of the pilot and ignite the pilot.
3. After control knob has been released and pilot stays lit, reinstall any items that were removed for pilot access. Close and latch stove door.
4. Call a qualified service technician for repair or replacement of the piezo ignitor.

**CLEANING AND SERVICING**

Annual inspection and cleaning by your dealer or qualified service technician is recommended to prevent malfunction and/or sooting.

**WARNING**

**Turn off heater and allow to cool before cleaning. Disconnect electrical power before cleaning or servicing.**

Remove logs, handling carefully by holding gently at each end. Gloves are recommended to prevent skin irritation from ceramic fibers. If skin becomes irritated, wash gently with soap and water. Refer to manual for correct log placement.

**PERIODIC CLEANING - See parts diagram for location of items discussed below.**

- Do not use cleaning fluid to clean logs or any part of heater.
- Brush logs with soft bristle brush or vacuum with brush attachment.
- Vacuum loose particles and dust from the front and rear burners, control and piezo covers and grate weldment.
- Inspect and clean burner air intake holes. Remove lint or particles with vacuum, brush, or pipe cleaners. Failure to keep air intake holes clean will result in sooting and poor combustion.
- External case should be dusted and wiped with a moist cloth.

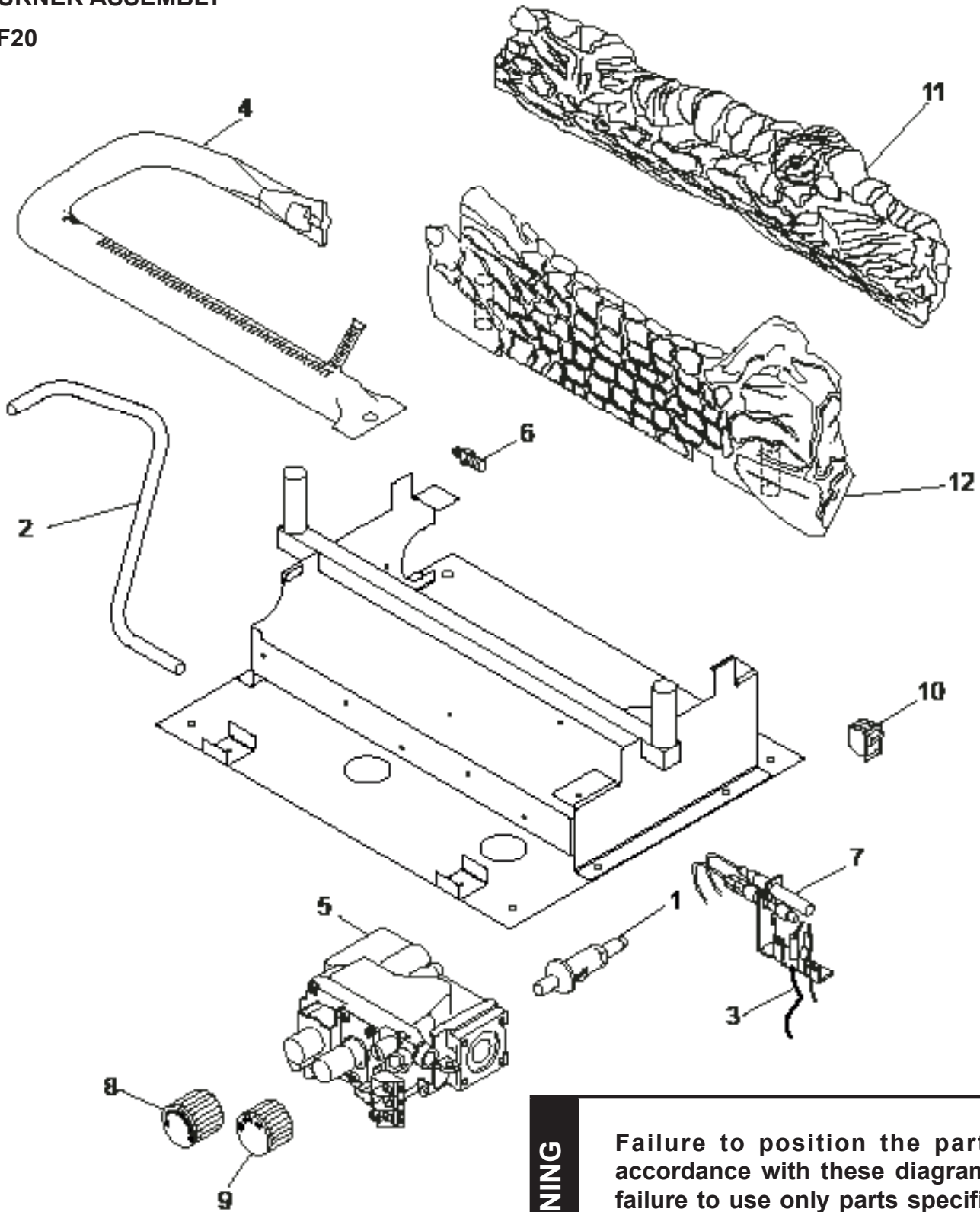
**ANNUAL CLEANING/INSPECTION - Refer to parts diagram for location of items discussed below.**

- Inspect and clean burner air intake holes. Remove lint or particles with vacuum, brush or pipe cleaners. Failure to keep air intake holes clean will result in sooting and poor combustion.
- Inspect and clean all burner ports.
- Inspect ODS pilot for operation and accumulation of lint at air intake holes.
- Verify flame pattern and log placement for proper operation.
- Verify smooth and responsive ignition of main burner and rear burner.

# REPLACEMENT PARTS

## BURNER ASSEMBLY

VF20



**WARNING**

Failure to position the parts in accordance with these diagrams or failure to use only parts specifically approved with this appliance may result in property damage or personal injury.



---

---

## REPLACEMENT PARTS LIST

---

---

*REPLACEMENT PARTS ARE AVAILABLE THROUGH YOUR RETAILER.*

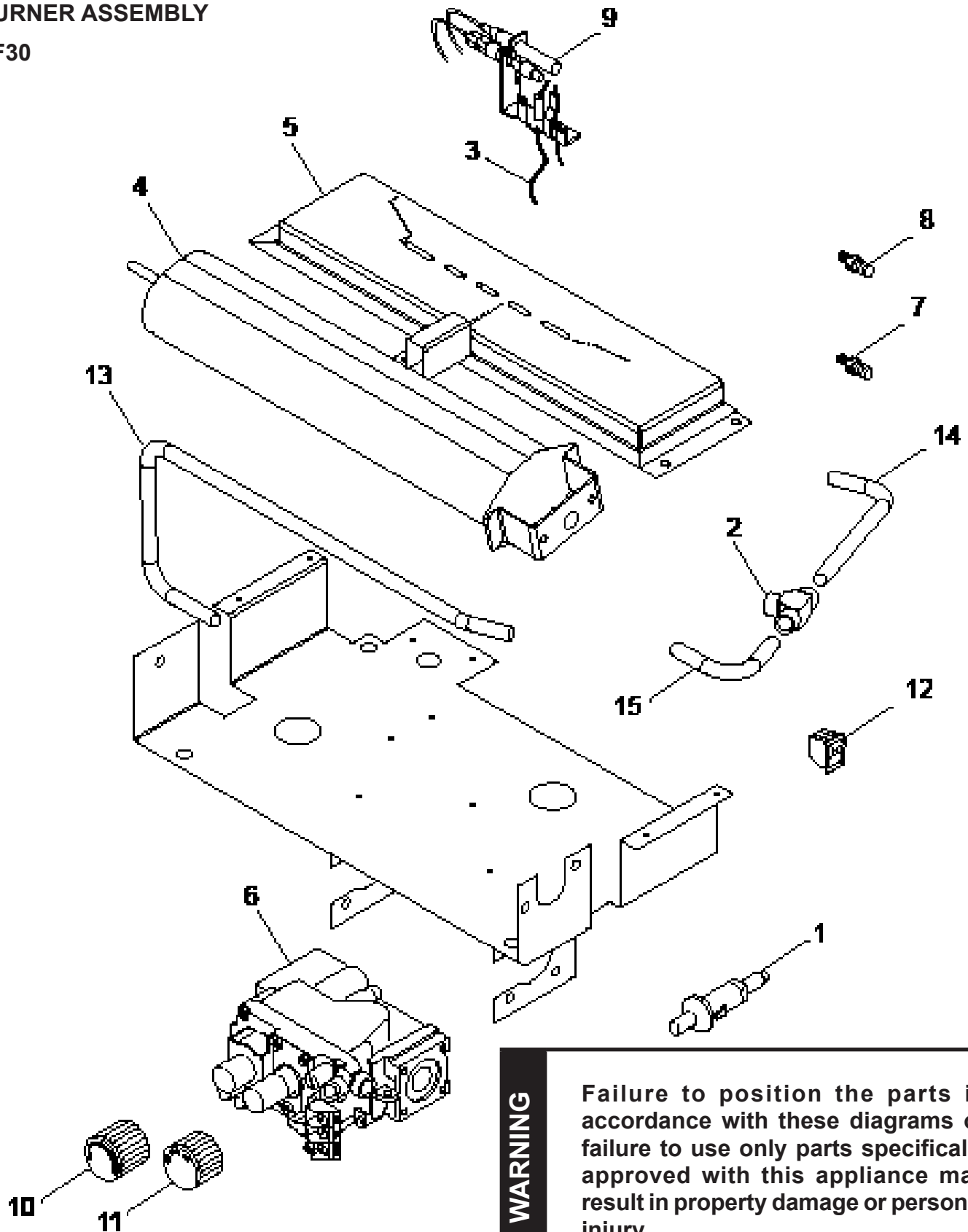
### BURNER ASSEMBLY

Item	Description	Qty	VF20	
			Natural	Propane
1	Piezo Igniter	1	14D0503	14D0503
2	VF Valve Tube	1	58D0519	58D0519
3	Piezo Wire	1	00K0632	00K0632
4	Burner	1	33D0070	33D0071
5	Control Valve	1	14D0467	14D0468
6	Burner Injector	1	33D0280	33D0281
7	ODS Pilot Assembly	1	14D0473	14D0477
8	On/Off Control Knob	1	43D0094	43D0094
9	Hi/Lo Control Knob	1	43D0095	43D0095
10	On/Off Switch	1	32D0232	32D0232
11	Rear Log	1	58D0527	58D0527
12	Front Log	1	58D0526	58D0526

Accessories	
Flex Connector	Flexcon 18
Wall Switch Kit	MVWS
Wall Thermostat Kit	WT
Hand Held Remote	RCM/RCB/WMTD
Hand Held Thermostat Remote	RCT/RCST/WWTD

# REPLACEMENT PARTS

## BURNER ASSEMBLY VF30



**WARNING** Failure to position the parts in accordance with these diagrams or failure to use only parts specifically approved with this appliance may result in property damage or personal injury.

---

---

**REPLACEMENT PARTS LIST**

---

*REPLACEMENT PARTS ARE AVAILABLE THROUGH YOUR RETAILER.*

**BURNER ASSEMBLY**

Item	Description	Qty	VF30	
			Natural	Propane
1	Piezo Ignitor	1	14D0503	14D0503
2	5/16 Union Tee	1	43D0181	43D0181
3	Piezo Wire	1	00K0632	00K0632
4	Front Burner	1	58D0193	58D0193
5	Rear Burner	1	58D0435	58D0435
6	Control Valve	1	14D0467	14D0468
7	Front Burner Injector	1	58D0061	58D0056
8	Rear Burner Injector	1	58D0061	62D3005
9	ODS Pilot Assembly	1	14D0473	14D0477
10	On/Off Control Knob	1	43D0094	43D0094
11	Hi/Lo Control Knob	1	43D0095	43D0095
12	On/Off Switch	1	32D0232	32D0232
13	VF Valve Tube	1	58D0427	58D0427
14	VF Rear Burner Tube	1	58D0428	58D0428
15	VF Front Burner Tube	1	58D0429	58D0429

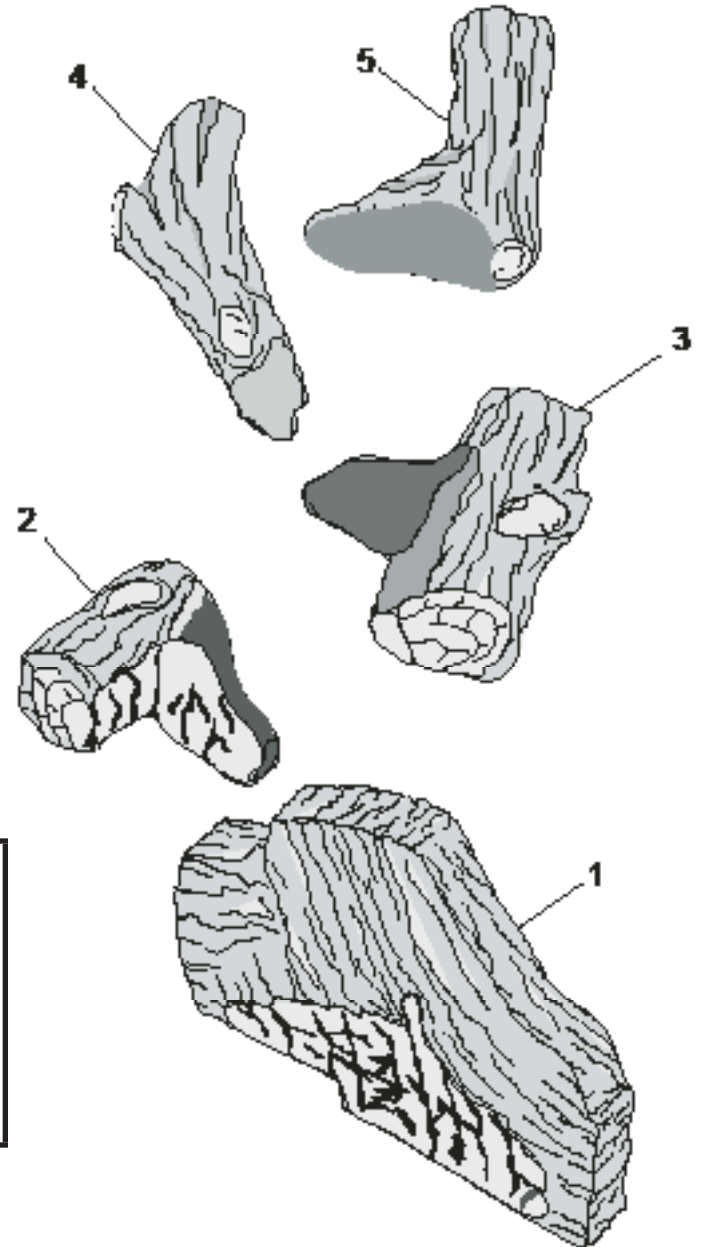
Accessories	
Flex Connector	Flexcon 18
Wall Switch Kit	MVWS
Wall Thermostat Kit	WT
Hand Held Remote	RCM/RCB/WMTD
Hand Held Thermostat Remote	RCT/RCST/WWTD

# REPLACEMENT PARTS LIST

REPLACEMENT PARTS ARE AVAILABLE THROUGH YOUR RETAILER.

## LOGS

Item	Description	Qty	VF30
1	Back Log	1	58D1901
2	Bottom Left Log	1	58D1902
3	Bottom Right Log	1	58D1903
4	Left Top Log	1	58D1904
5	Right Top Log	1	58D1905



### WARNING

Failure to position the parts in accordance with these diagrams or failure to use only parts specifically approved with this appliance may result in property damage or personal injury.

**WARNING**

Turn appliance OFF and allow to cool before servicing. Only a qualified service person should service and repair the heater.

*Note: All troubleshooting items are listed in order of operation.*

<b>SYMPTOM</b>	<b>POSSIBLE CAUSE</b>	<b>ACTION</b>
<b>When ignitor button is pressed, there is no spark at ODS/pilot.</b>	1. Ignitor electrode positioned wrong.	1. Replace ignitor.
	2. Ignitor electrode is broken.	2. Replace ignitor.
	3. Ignitor electrode not connected to ignitor cable.	3. Reconnect ignitor cable.
	4. Ignitor cable pinched or wet. Keep ignitor cable dry.	4. Free ignitor cable if pinched by any metal or tubing.
	5. Broken ignitor cable.	5. Replace ignitor cable.
	6. Bad piezo ignitor.	6. Replace piezo ignitor.
<b>Appliance produces unwanted odors.</b>	1. Appliance burning vapors from paint, hair spray, glues, etc.	1. Ventilate room. Stop using odor causing products while heater is running.
	2. Gas leak	2. Locate and correct all leaks.
	3. Initial burn off.	3. Ventilate room and turn unit on high until odor is gone. Odor should be gone after 2 to 3 hours of continuous use.
<b>Appliance shuts off during use.</b>	1. Not enough fresh air is available for ODS/ pilot to operate.	1. Open window and/or door for ventilation.
	2. Low line pressure.	2. Contact local gas company.
	3. ODS/pilot is partially clogged.	3. Clean ODS/pilot.
	4. Defective Thermopile.	4. Check pilot flame. Check wire connections. Check thermopile output — should be 500 millivolts across TH/TP and TP Terminals with ON/OFF switch off.
	5. Restrictions in incoming air flow.	5. Check for obstructions on bottom of unit. Check for improper log placement.
<b>Gas odor even when control knob is in OFF position.</b>	1. Gas leak.	1. Locate and correct all leaks.
	2. Control valve defective.	2. Replace control valve.

## TROUBLESHOOTING

### WARNING

If the gas quality is bad, your pilot may not stay lit, the burners may produce soot and the heater may backfire when lit. If the gas quality or pressure is low, contact your local gas supplier immediately.

SYMPTOM	POSSIBLE CAUSE	ACTION
<b>ODS/pilot lights, but flame goes out when control knob is released.</b>	1. Control knob not fully pressed in.	1. Press in control knob fully.
	2. Control knob not pressed in long enough.	2. After ODS/pilot lights, keep control knob pressed in for 30 seconds.
	3. Appliance shutoff valve not fully open.	3. Fully open manual shutoff valve.
	4. Thermocouple connection loose at control valve.	4. Hand tighten thermocouple connection until snug, then tighten 1/4 turn more.
	5. Pilot flame not touching thermocouple, which allows thermocouple to cool, causing pilot flame to go out.	5. Contact local gas company. This problem could be caused by either low gas pressure, or a dirty or partially clogged ODS/pilot.
	6. Thermocouple damaged.	6. Replace pilot.
<b>Burner does not light after ODS/pilot is lit.</b>	1. Inlet gas pressure is too low.	1. Contact qualified service person.
	2. Burner orifice diameter is too small.	2. Replace burner orifice.
	3. Burner orifice is clogged.	3. Burner orifice is clogged.
<b>Burner backfires during combustion.</b>	1. Manifold pressure is too low.	1. Contact local gas company.
	2. Burner orifice is clogged.	2. Clean burner or replace burner orifice.
<b>Slight smoke or odor during initial operation.</b>	1. Burner orifice is clogged or damaged.	2. Replace burner.
	2. Burner is damaged.	2. Replace burner.
	3. Gas regulator defective.	3. Replace gas regulator.
<b>Logs appear to smoke after initial operation.</b>	1. Vapors from paint or curing process of logs.	1. Problem will stop after a few hours of operation. Open a window for the first few hours.
		2. Log heater is intended to be smokeless. Turn OFF heater and call qualified service person.
<b>Heater produces a whistling noise when burner is lit.</b>	1. Vapors from paint or curing process of logs.	1. Problem will stop after a few hours of operation. Open a window for the first few hours.
	2. Air in gas line.	2. Operate burner until air is removed from line. Have gas line checked by local gas company.
	3. Dirty or partially clogged burner orifices.	3. Clean burner or replace burner orifice.
<b>No gas to pilot.</b>	1. LP-regulator shut down due to inlet pressure too high.	1. Verify LP tank regulator is installed and set at 11" to 13" w.c.

## Massachusetts Residents Only — Please read and follow these special requirements

### NOTE REGARDING VENTED PRODUCTS

This product must be installed by a licensed plumber or gas fitter when installed within the Commonwealth of Massachusetts.

Any residence with a direct vent product must have a CO detector installed in the residence.

Installation of the fireplace or vented gas log in the State of Massachusetts requires the damper to be permanently removed or welded in the fully open position.

In addition, a naturally vented gas log may not be installed in a bedroom or bathroom in the State of Massachusetts.

Flex line installation must not exceed 36 inches and must have a T shutoff valve.

### NOTE REGARDING VENT FREE PRODUCTS

This product must be installed by a licensed plumber or gas fitter when installed within the Commonwealth of Massachusetts.

In addition, vent free products may not be installed in a bedroom or bathroom regardless of size or type in the State of Massachusetts.

Flex line installation must not exceed 36 inches and must have a T shutoff valve.

### CARBON MONOXIDE DETECTOR REQUIREMENTS

(2) Revise 10.8.3 by adding the following additional requirements:

(a) For all side wall horizontally vented gas fueled equipment installed in every dwelling, building or structure used in whole or in part for residential purposes, including those owned or operated by the Commonwealth and where the side wall exhaust vent termination is less than seven (7) feet above finished grade in the area of the venting, including but not limited to decks and porches, the following requirements shall be satisfied:

1. **Installation of carbon monoxide detectors.** At the time of installation of the side wall horizontal vented gas fueled equipment, the installing plumber or gas fitter shall observe that a hard wired carbon monoxide detector with an alarm and battery back-up is installed on the floor level where the gas equipment is to be installed. In addition, the installing plumber or gas fitter shall observe that a battery operated or hard wired carbon monoxide detector with an alarm is installed on each additional level of the dwelling, building or structure served by the side wall horizontal vented gas fueled equipment. It shall be the responsibility of the property owner to secure the services of qualified licensed professionals for the installation of hard wired carbon monoxide detectors

a. In the event that the side wall horizontally vented gas fueled equipment is installed in a crawl space or an attic, the hard wired carbon monoxide detector with alarm and battery back-up may be installed on the next adjacent floor level.

b. In the event that the requirements of this subdivision can not be met at the time of completion of installation, the owner shall have a period of thirty (30) days to comply with the above requirements; provided, however, that during said thirty (30) day period, a battery operated carbon monoxide detector with an alarm shall be installed.

2. **Approved Carbon Monoxide Detectors.** Each carbon monoxide detector as required in accordance with the above provisions shall comply with NFPA 720 and be ANSI/UL 2034 listed and IAS certified.

3. **Signage.** A metal or plastic identification plate shall be permanently mounted to the exterior of the building at a minimum height of eight (8) feet above grade directly in line with the exhaust vent terminal for the horizontally vented gas fueled heating appliance or equipment. The sign shall read, in print size no less than one-half (1/2) inch in size, "GAS VENT DIRECTLY BELOW. KEEP CLEAR OF ALL OBSTRUCTIONS."

4. **Inspection.** The state or local gas inspector of the side wall horizontally vented gas fueled equipment shall not approve the installation unless, upon inspection, the inspector observes carbon monoxide detectors and signage installed in accordance with the provisions of 248 CMR 5.08(2)(a)1 through 4.

(b) **Exemptions:** The following equipment is exempt from 248 CMR 5.08(2)(a)1 through 4:

1. The equipment listed in Chapter 10 entitled "Equipment Not Required To Be Vented" in the most current edition of NFPA 54 as adopted by the Board; and

2. Product Approved side wall horizontally vented gas fueled equipment installed in a room or structure separate from the dwelling, building or structure used in whole or in part for residential purposes.

(c) **Manufacturer requirements — Gas Equipment Venting System Provided.** When the manufacturer of Product Approved side wall horizontally vented gas equipment provides a venting system design or venting system components with the equipment, the instructions provided by the manufacturer for installation of the equipment and the venting system shall include:

1. Detailed instructions for the installation of the venting system design or the venting system components; and

2. A complete parts list for the venting system design or venting system.

(d) **Manufacturer requirements — Gas Equipment Venting System Not Provided.** When the manufacturer of a Product Approved side wall horizontally vented gas fueled equipment does not provide the parts for venting the flue gases, but identifies "special venting systems," the following requirements shall be satisfied by the manufacturer:

1. The referenced "special venting system" instructions shall be included with the appliance or equipment installation instructions; and

2. The "special venting systems" shall be Product Approved by the Board, and the instructions for that system shall include a parts list and detailed installation instructions.

(e) A copy of all installation instructions for all Product Approved side wall horizontally vented gas fueled equipment, all venting instructions, all parts lists for venting instructions, and/or all venting design

# Limited Lifetime Warranty

MHSC warrants its products to be free of defects in material and workmanship and backs each product with a Limited Lifetime Warranty. This warranty is to the original purchaser of a MHSC product and is not transferable.

## LIFETIME WARRANTY

Covered under this warranty are the stove body, combustion chamber, door frame, gold plating (manufacturing defects only), glass (thermal breakage only), heat exchange system, and burner. This coverage includes parts and reasonable labor during the first five years of ownership and parts only thereafter.

## FIVE YEAR WARRANTY

Ceramic fiber logs, firebrick panels and secondary air tubes are covered for a period of five years from the date of purchase.

## TWO YEAR WARRANTY

Gas valves, pilot assemblies, thermopiles, thermocouples, regulators, electrical components, cast iron grates and blowers are covered for a period of two years from the date of purchase.

## EXCLUSIONS

Items that are not covered under this warranty include but are not limited to damage or chipping to any component surfaces, gasketing, refractory material, or trim. It does not cover installation or operational problems related to venting systems, inadequate draft, inadequate gas pressure, adjustments to the appliance, the cost of inspection, components which have been altered or modified, labor costs, removal and re-installation costs, shipping to or from the factory or authorized service center, shipping damage, damage from improper use or neglect, installation damage, damage from unauthorized service, incidental or consequential damage or negative pressure caused by mechanical systems such as furnaces, fans, clothes dryers etc.

## TERMS

This warranty shall be void if the appliance is not installed a by qualified installer in accordance with the installation instructions provided with the appliance and state and local codes. The warranty shall also be void if the appliance is not operated and maintained in accordance with the operating instructions supplied with the appliance. All service work must be performed by an authorized service representative. Any part or parts, which we deem defective, will be repaired or replaced at MHSC's option, through an authorized dealer or service provider.

This warranty is expressly in lieu of other warranties, express or implied, including the warranty of merchantability of fitness for purpose and of all other obligations or liabilities. MHSC does not assume for it any other obligations or liability in connection with the sale or use of the appliance. In states that do not allow limitations on how long an implied warranty lasts, or do not allow exclusion of indirect damages, those limitations of exclusions may not apply to you. You may also have additional rights not covered in this Limited Warranty.

MHSC reserves the right to investigate any and all claims against the Limited Warranty and decide upon the method of settlement.

## IF WARRANTY SERVICE IS NEEDED...

1. Contact your supplier. Make sure you have your warranty, your sales receipt and the model/serial number of your MHSC product.
2. DO NOT ATTEMPT TO DO ANY SERVICE WORK YOURSELF.