

Catalog Number
Notes
Type

## FEATURES & SPECIFICATIONS

**INTENDED USE** — Multiple length and lumen packages make this versatile LED strip light ideal for a variety of residential and commercial applications. **Certain airborne contaminants can diminish the integrity of acrylic and/or polycarbonate.** [Click here for Acrylic-Polycarbonate Compatibility table for suitable uses.](#)

Certain airborne contaminants may adversely affect the functioning of LEDs and other electronic components, depending on various factors such as concentrations of the contaminants, ventilation, and temperature at the end-user location. [Click here for a list of substances that may not be suitable for interaction with LEDs and other electronic components.](#)

**CONSTRUCTION** — Compact-design channel and cover are formed from code-gauge cold-rolled steel. High-gloss, baked white enamel finish (standard).

**OPTICS** — LEDs provided 80+ color rendering index (CRI) at 4000K. Diffuse acrylic lens provides smooth, linear illumination.

**ELECTRICAL** — Luminaire Surge Protection Level: Designed to withstand up to 2.5kV/0.75kA per ANSI C82.77-5-2015. For applications requiring higher level of protection, additional surge protection must be provided.

**INSTALLATION** — Fixture may be surface or suspension mounted with appropriate mounting options (see accessories). Easy to install row aligner included for continuous row mounting.

**LISTINGS** — CSA certified to US and Canadian safety standards and listed suitable for damp locations. Minimum starting temperature at -40°F (-40°C). Maximum ambient operating temperature of 95°F (35°C).

**WARRANTY** — 5-year limited warranty. This is the only warranty provided and no other statements in this specification sheet create any warranty of any kind. All other express and implied warranties are disclaimed. Complete warranty terms located at: [www.acuitybrands.com/support/warranty/terms-and-conditions](http://www.acuitybrands.com/support/warranty/terms-and-conditions)

**NOTE:** Actual performance may differ as a result of end-user environment and application. All values are design or typical values, measured under laboratory conditions at 25°C. Specifications subject to change without notice.



LED Strip Light

# MNSS



### ORDERING INFORMATION

Lead times will vary depending on options selected. Consult with your sales representative.

Catalog number	Description	Lumens	Wattage	Voltage	Color Temperature	Pallet Quantity	Pallet Dimensions
MNSS L48 5500LM MVOLT GZ10 40K	4' MVOLT strip light	5500	51W	MVOLT (120-277V)	40K 4000K	98	46 x 57
MNSS L48 7000LM MVOLT GZ10 40K	4' High Lumen Strip Light	7500	60W	MVOLT (120-277V)	40K 4000K		
MNSS L96 11000LM MVOLT GZ10 40K	8' MVOLT strip light	11000	102W	MVOLT (120-277V)	40K 4000K	102	46 x 98.5
MNSS L96 14000LM MVOLT GZ10 40K	8' High Lumen Strip Light	15000	120W	MVOLT (120-277V)	40K 4000K		

Accessories: Order as separate catalog number.	
HC36	Chain hanger and jack chain, 36" (pair)
ZACVH	Aircraft cable 10' (one pair)
SQ	5/8" Swivel-stem hanger (specify length in 2" increments)
Y J10	Y hanger in multiples of 10

PROJECTED LUMEN MAINTENANCE			
Luman Maintenance Factor	.70	.80	.90
Operating Hours	40,000	90,000	120,000

\*Actual performance may vary based on ambient temperature of installed location.

# MNSS LED Strip Light

## DIMENSIONS

All dimensions are in inches.

Length	Width	Height	Approximate weight
L48	2.62	2.22	5 lbs
L96	2.62	2.22	10 lbs

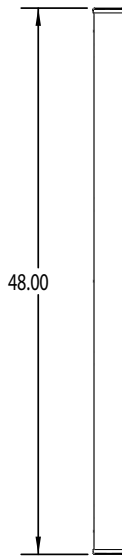

### 4FT Assembly

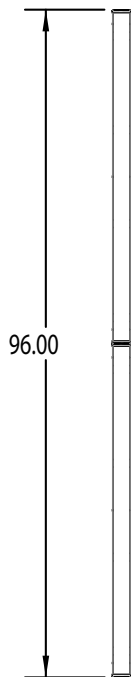
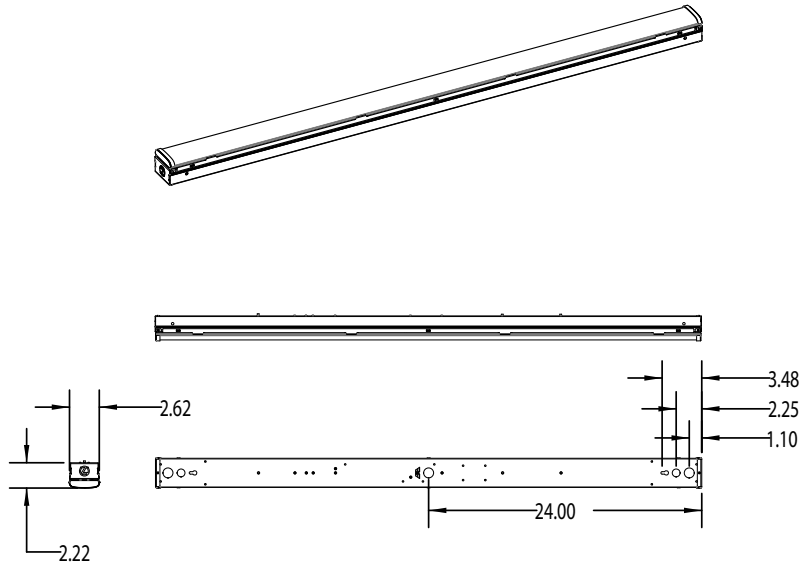

### 8FT Assembly

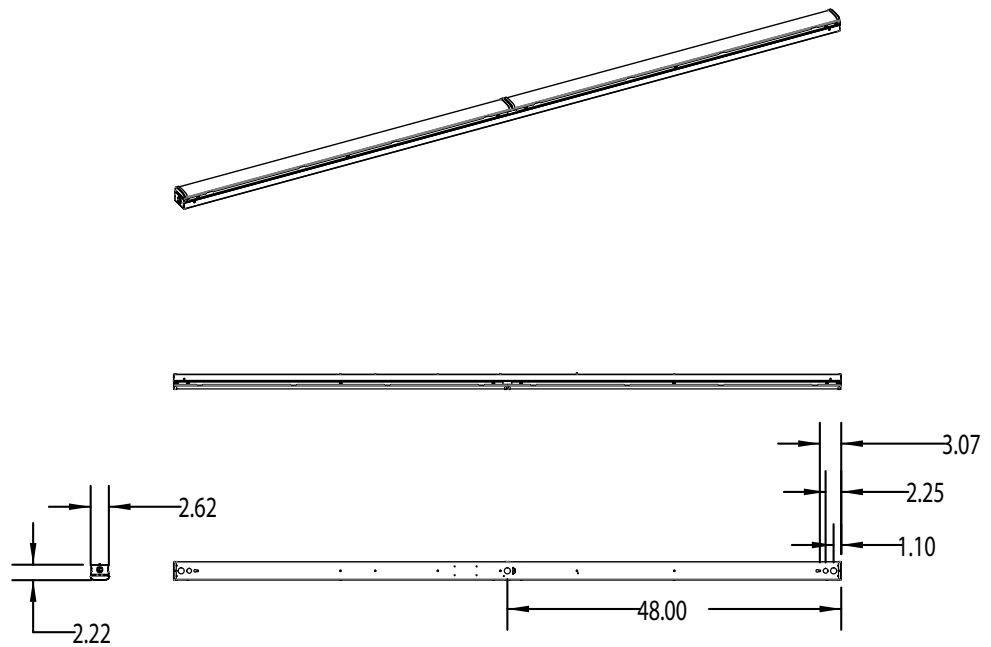

## PHOTOMETRICS

See [www.lithonia.com](http://www.lithonia.com).