

### SNAP-IN FIXTURE MOUNT BRACKET

#### SPECIFICATIONS

##### APPLICATIONS

Enables lower mounting of sensors in order to avoid view impediments

##### FEATURES

3 Sensor Mounting Positions  
Simple Snap-in Design  
Made in U.S.A.

##### PHYSICAL SPECS

SIZE (main bracket housing)

5.00" H x 2.00" W x 1.35" D

(12.70 cm H x 5.08 cm W x 3.43 cm D)

WEIGHT 2.52 oz each (excluding nuts)

MOUNTING 1/2" knockout

The FB3 Series Snap-in Fixture Bracket provides a convenient method of lowering a fixture mount style sensor such that its view is not impeded by edge of luminaire. Three sensor mounting positions provide flexibility for usage on a wide variety of fixtures.

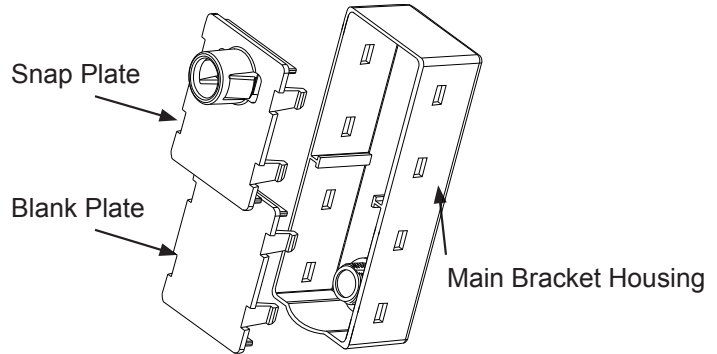

#### MOUNTING INSTRUCTIONS

1. Mount sensor to *main bracket housing* using lock washer and nut.

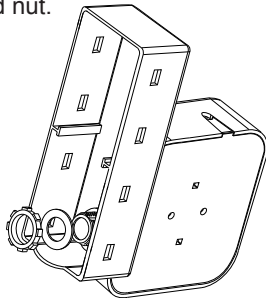

2. Attach the *snap plate* and *blank plate* to *main bracket housing* in one of three configurations (figures a-c) such that bottom of *main bracket housing* will be flush or lower than bottom edge of fixture once attached.

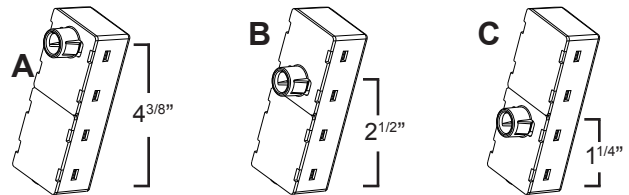

3. Snap entire assembly to fixture via 1/2" knockout.

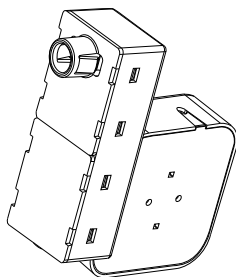

4. Rotate/Align the sensor such that the sensor lens is parallel to floor.

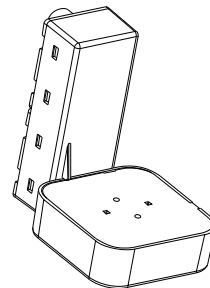

#### ORDERING INFO

##### MODEL NUMBER

FB3  
FB3 J100

##### DESCRIPTION

Snap-in Fixture Mount Bracket  
Snap-in Fixture Mount Bracket (100 count box)