



**WARNING: Risk of scalding.**  
 High water temperature can cause severe burns. Set the water temperature at or below 120°F (49°C) following the adjustment procedure in the valve Installation and Care Guide.

**AVERTISSEMENT: Risque de brûlures.**  
 Une température élevée peut causer des brûlures graves. Régler la température de l'eau à 120°F (49°C) ou moins en suivant la procédure de réglage fournie dans le guide d'installation et d'entretien du robinet.

**ADVERTENCIA: Riesgo de quemaduras.**  
 El agua a alta temperatura puede ocasionar quemaduras graves. Ponga la temperatura del agua a un máximo de 120°F (49°C), de acuerdo al procedimiento de ajuste en la Guía de instalación y cuidado de válvulas.

Observe all local plumbing and building codes.  
**Record your model number below for future reference:**

Respecter tous les codes de plomberie et de bâtiment locaux.  
**Consigner le numéro de modèle ci-dessous pour toute référence ultérieure:**

Cumpla todos los códigos locales de plomería y construcción.  
**Anote abajo el número de su modelo como referencia futura:**

**For service parts information, visit [www.kohler.com/serviceparts](http://www.kohler.com/serviceparts).**  
**For service kit information, refer to the Specification Sheet on your product page at [www.kohler.com](http://www.kohler.com).**  
**Pour tout renseignement sur les pièces de rechange, visitez [www.kohler.com/serviceparts](http://www.kohler.com/serviceparts).**  
**Pour tout renseignement sur les kits, consultez la fiche technique sur la page du produit à [www.kohler.com](http://www.kohler.com).**

**Para consultar información sobre piezas de repuesto, visite [www.kohler.com/serviceparts](http://www.kohler.com/serviceparts).**  
**Para consultar información sobre el kit de servicio consulte la hoja de especificación en la página de su producto en [www.kohler.com](http://www.kohler.com).**

**1** Remove the plaster guard. Turn on the water.  
 Retirer le protège-plâtre. Ouvrir l'arrivée d'eau.  
 Retire el protector de yeso. Abra el agua.

**2** To adjust maximum water temperature, refer to the User Guide at [www.kohler.com](http://www.kohler.com).  
 Pour régler la température maximale de l'eau, se reporter au guide de l'utilisateur à [www.kohler.com](http://www.kohler.com).  
 Para ajustar la temperatura máxima del agua, consulte la Guía del usuario en [www.kohler.com](http://www.kohler.com).

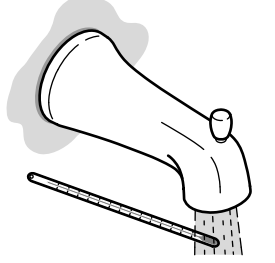
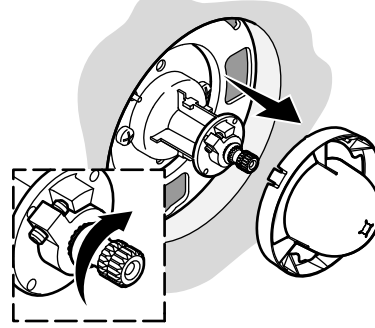

**3** Turn off the water.  
 Couper l'arrivée d'eau.  
 Cierre el agua.

**4 Diverter Valves Only:** Install the sleeve.  
**Pour les robinets d'inverseurs seulement:** Poser le manchon.  
**Solo válvulas desviadoras:** Instale la manga.

**5** Measure dimension "Y" to determine the appropriate adapter.  
 Mesurer la dimension "Y" pour déterminer l'adaptateur approprié.  
 Mida la dimensión "Y" para determinar cuál es el adaptador apropiado.

**6** Install the short adapter when "Y" is within the dimensions below.  
 Installer l'adaptateur court lorsque la dimension "Y" est comprise dans les dimensions ci-dessous.  
 Instale el adaptador corto cuando el valor "Y" esté dentro de las siguientes dimensiones.

**7** If "Y" is within the dimensions below, orient and install the reversible adapter as shown.  
 Si la dimension "Y" est comprise dans les dimensions ci-dessous, orienter et installer l'adaptateur réversible comme sur l'illustration.  
 Si la dimensión "Y" está dentro de las siguientes dimensiones, oriente e instale el adaptador reversible como se muestra.

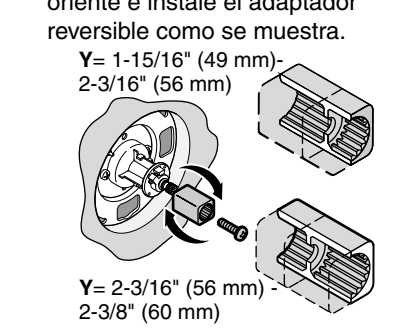
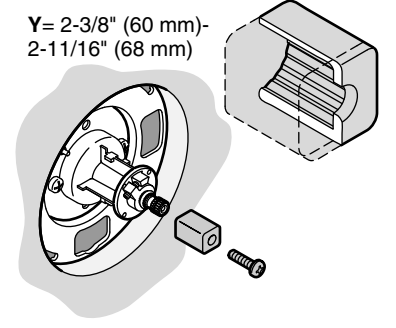
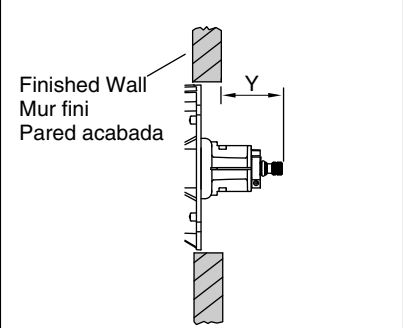
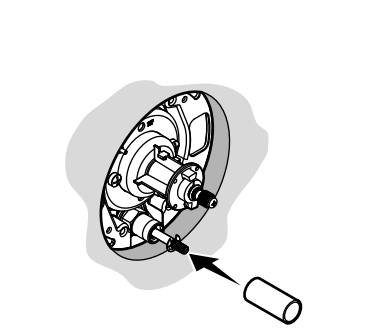
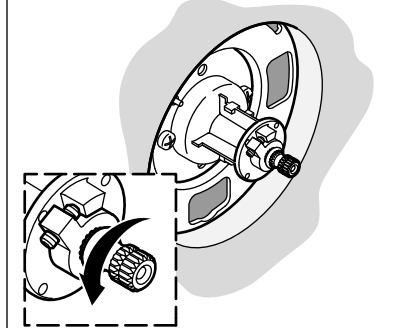

**8 All Installations:** Snap the retainer to the seal plate.  
**Toutes les poses:** Encliqueter la pièce de retenue dans le plateau d'étanchéité.  
**Todas las instalaciones:** Encaje el retenedor a la placa de sellado.

**9 Tiled Wall Installations Only:** Apply sealant to the back of the seal plate.  
**Pose sur mur carrelé seulement:** Appliquer du mastic sur le dos du plateau d'étanchéité.  
**Solo en instalaciones en pared de azulejo:** Aplique sellador al lado posterior de la placa de sellado.

**IMPORTANT: For K-2971 Valve:** If the finished wall is **less than 13/16" (21 mm) thick, do not use the 2-3/8" (60 mm) screws.** The 1-5/8" (41 mm) screws **must** be used.  
**IMPORTANT: Vanne K-2971:** Si l'épaisseur du mur fini est **inférieure à 13/16" (21 mm), ne pas utiliser les vis de 2-3/8" (60 mm).** Les vis de 1-5/8" (41 mm) **doivent** être utilisées.  
**IMPORTANTE: Con la válvula K-2971:** Si la pared acabada tiene un grosor de **menos de 13/16" (21 mm), no utilice los tornillos de 2-3/8" (60 mm).** **Debe** usar los tornillos de 1-5/8" (41 mm).

**10** Install the retainer and seal plate.  
 Poser le dispositif de retenue et le plateau d'étanchéité.  
 Instale el retenedor y la placa de sellado.

**11** Fit the faceplate over the seal plate and retainer with the notch down.  
 Adapter la plaque de garniture sur le plateau d'étanchéité et le dispositif de retenue avec l'encoche vers le bas.  
 Coloque la placa frontal sobre la placa de sellado y el retenedor con la muesca hacia abajo.

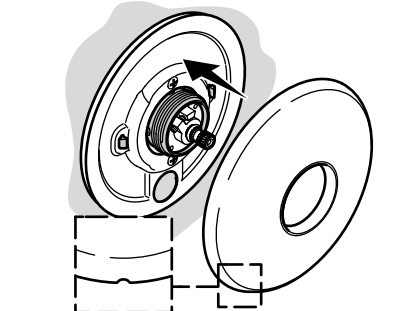
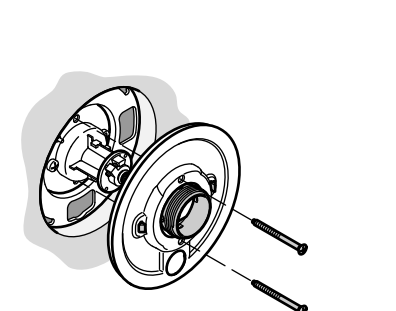
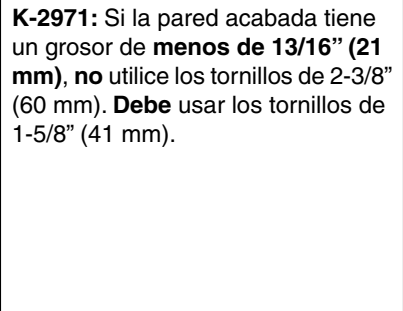
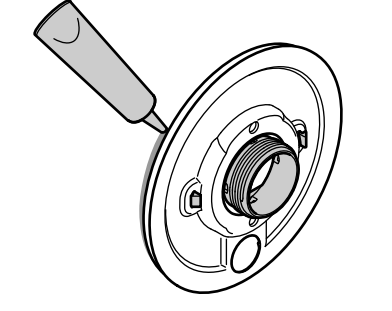
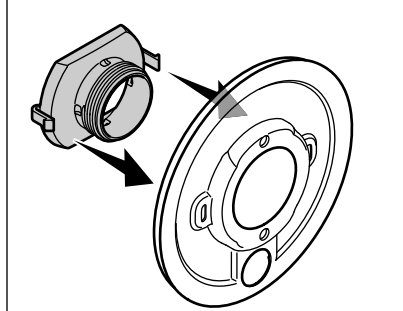

**12 Diverter Valves Only:** While holding the valve stem, install the button. Then install the knob.  
**Pour les robinets d'inverseurs seulement:** Poser le bouton, tout en tenant la tige de la vanne. Poser ensuite le bouton.  
**Solo válvulas desviadoras:** Mientras sostiene la espiga de la válvula, instale el botón. Luego instale la perilla.

**13** Point the handle down.  
 Handtighten the bonnet onto the retainer.  
 Pointer la poignée vers le bas.  
 Serrer le chapeau à la main sur la pièce de retenue.  
 Apunte la manija hacia abajo.  
 Apriete a mano el bonete en el retenedor.

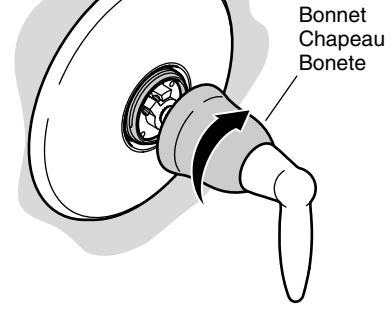
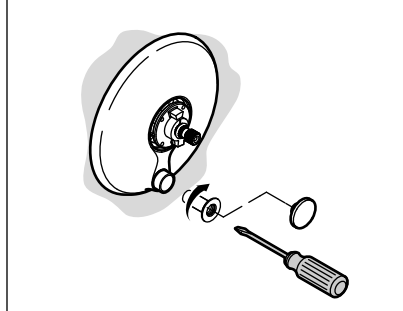

<p><b>Need help?</b> Contact the KOHLER Customer Care Center at 1-800-4KOHLER (1-800-456-4537).</p> <p><b>For service parts information,</b> visit <a href="http://www.kohler.com/serviceparts">www.kohler.com/serviceparts</a>.</p> <p><b>For care and cleaning</b> and other information, visit <a href="http://www.us.kohler.com">www.us.kohler.com</a>.</p>	<p><b>Besoin d'aide?</b> Appeler le centre de services à la clientèle de KOHLER au 1-800-4KOHLER (1-800-456-4537).</p> <p><b>Pour tout renseignement sur les pièces de rechange,</b> visiter <a href="http://www.kohler.com/serviceparts">www.kohler.com/serviceparts</a>.</p> <p><b>Pour tout renseignement sur l'entretien, le nettoyage</b> et autre, visiter <a href="http://www.us.kohler.com">www.us.kohler.com</a>.</p>	<p><b>¿Necesita ayuda?</b> Comuníquese con el Centro de Atención al Cliente de KOHLER al 1-800-4KOHLER (1-800-456-4537).</p> <p><b>Para consultar información sobre piezas de repuesto,</b> visite <a href="http://www.kohler.com/serviceparts">www.kohler.com/serviceparts</a>.</p> <p><b>Para el cuidado y la limpieza,</b> y más información, visite <a href="http://www.us.kohler.com">www.us.kohler.com</a>.</p>
<p><b>KOHLER® Faucet Lifetime Limited Warranty</b></p> <p>Kohler Co. warrants its Faucets* manufactured after January 1, 1997, to be leak and drip free during normal residential use for as long as the original consumer purchaser owns his or her home. If the Faucet should leak or drip during normal use, Kohler Co. will, free of charge, mail to the purchaser the cartridge necessary to put the Faucet in good working condition. This warranty applies only to Kohler Faucets installed in the United States of America, Canada or Mexico ("North America").</p> <p>Kohler Co. also warrants all other aspects of the faucet or accessories ("Faucet")*, (except gold, non-Vibrant®, non-chrome finishes) to be free of defects in material and workmanship during normal residential use for as long as the original consumer purchaser owns his or her home. This warranty applies only to Kohler Faucets installed in North America. If a defect is found in normal residential use, Kohler Co. will, at its election, repair, provide a replacement part or product, or make appropriate adjustment. Damage to a product caused by accident, misuse, or abuse is not covered by this warranty. Improper care and cleaning will void the warranty**. Proof of purchase (original sales receipt) must be provided to Kohler Co. with all warranty claims. Kohler Co. is not responsible for labor charges, installation, or other incidental or consequential costs. In no event shall the liability of Kohler Co. exceed the purchase price of the Faucet.</p> <p>If the Faucet is used commercially or is installed outside of North America, or if the finish is gold, non-Vibrant or a painted or powder coated color finish, Kohler Co. warrants the Faucet to be free from defects in material and workmanship for one (1) year from the date the product is installed, under Kohler Co.'s standard one-year limited warranty.</p> <p>If you believe that you have a warranty claim, contact Kohler Co., either through your Dealer, Plumbing Contractor, Home Center or E-tailer, or by writing Kohler Co., Attn.: Customer Care Center, 444 Highland Drive, Kohler, WI 53044, USA. Please be sure to provide all pertinent information regarding your claim, including a complete description of the problem, the product, model number, color, finish, the date the product was purchased and from whom the product was purchased. Also include your original invoice. For other information, or to obtain the name and address of the service and repair facility nearest you, call 1-800-4-KOHLER (1-800-456-4537) from within the USA and Canada, and 001-800-456-4537 from within Mexico, or visit <a href="http://www.kohler.com">www.kohler.com</a> within the USA, <a href="http://www.ca.kohler.com">www.ca.kohler.com</a> from within Canada, or <a href="http://www.mx.kohler.com">www.mx.kohler.com</a> in Mexico.</p> <p><b>KOHLER CO. AND/OR SELLER ARE PROVIDING THESE WARRANTIES IN LIEU OF ALL OTHER WARRANTIES, EXPRESSED OR IMPLIED, INCLUDING BUT NOT LIMITED TO THE IMPLIED WARRANTIES OF MERCHANTABILITY AND FITNESS FOR A PARTICULAR PURPOSE. KOHLER CO. AND/OR SELLER DISCLAIM ALL LIABILITY FOR SPECIAL, INCIDENTAL OR CONSEQUENTIAL DAMAGES. Some states/provinces do not allow limitations of how long an implied warranty lasts or the exclusion or limitation of such damages, so these limitations and exclusions may not apply to you. This warranty gives the consumer specific legal rights. You may also have other rights that vary from state/province to state/province.</b></p> <p><b>This is Kohler Co.'s exclusive written warranty.</b></p> <p>*Trend® faucets, MasterShower® tower, BodySpa systems and components; WaterHaven® tower, systems and components; Tripoint® faucets, Polished Gold, non-Vibrant and painted or powder coated finishes, fittings; all items within the "Fixture Related" section of the Kohler Faucets Price Book, drains, Duostrainer® sink strainers, soap/lotion dispensers, Moxie® Wireless Speaker; and faucets used in commercial settings, and outside North America, are covered by Kohler Co.'s one-year limited warranty.</p> <p>**Never use cleaners containing abrasive cleansers, ammonia, bleach, acids, waxes, alcohol, solvents or other products not recommended for chrome. This will void the warranty.</p> <p>USA/Canada: 1-800-4KOHLER Mexico: 001-800-456-4537 <a href="http://www.kohler.com">www.kohler.com</a></p>	<p><b>Garantie limitée à vie du robinet KOHLER®</b></p> <p>Kohler Co. garantit que les robinets* fabriqués après le 1er janvier 1997 ne fuient pas et ne gouttent pas lors d'une utilisation domestique normale, aussi longtemps que l'acquéreur d'origine demeure propriétaire de son domicile. Si le robinet goutte ou présente des fuites lors d'une utilisation normale, Kohler Co. enverra par courrier à l'acheteur, sans frais, la cartouche nécessaire pour réparer le robinet. La présente garantie s'applique uniquement aux robinets Kohler installés aux États-Unis, au Canada ou au Mexique ("Amérique du Nord").</p> <p>Kohler Co. garantit également toutes les autres caractéristiques du robinet ou des accessoires ("Robinet")*, (à l'exception des finitions dorées, non-Vibrant®, non chromées) contre tout vice de matériau et de fabrication lors d'une utilisation domestique normale, aussi longtemps que l'acquéreur d'origine demeure propriétaire de son domicile. La présente garantie s'applique uniquement aux robinets Kohler installés en Amérique du Nord. Si un vice est décelé lors d'une utilisation domestique normale, Kohler Co. choisira, à sa discrétion, la réparation, le remplacement ou la rectification appropriée. Cette garantie n'offre pas de protection contre les dommages dus à un accident, une mauvaise utilisation ou un mauvais traitement. Un entretien et un nettoyage inadéquats annulent la garantie**. Une preuve d'achat (ticket de caisse d'origine) doit être présentée à Kohler Co. avec toutes les réclamations au titre de la garantie. Kohler Co. n'est pas responsable des frais de main-d'œuvre, d'installation ou de tout autre frais particulier, accessoire ou indirect. La responsabilité de Kohler Co. ne dépassera en aucun cas le prix d'achat du robinet.</p> <p>Si le robinet est utilisé dans un commerce ou s'il est installé en dehors d'Amérique du Nord, ou si la finition est dorée, non-Vibrant, peinte ou revêtue d'une poudre, Kohler Co. garantit le robinet contre tout vice de matériau et de fabrication pendant un (1) an à partir de la date d'installation du produit, selon les modalités de la garantie limitée standard d'un an de Kohler Co.</p> <p>Pour toute réclamation au titre de la présente garantie, contacter Kohler Co. par l'intermédiaire du vendeur, plombier, centre de rénovation ou revendeur par internet, ou bien par écrit à l'adresse suivante Kohler Co., Attn.: Customer Care Center, 444 Highland Drive, Kohler, WI 53044, USA. Fournir tous les renseignements pertinents à la réclamation, dont notamment une description complète du problème et du produit, le numéro de modèle, la couleur, la finition, la date et le lieu d'achat du produit. Joindre également l'original de la facture. Pour de plus amples renseignements ou pour obtenir les coordonnées du service de réparation le plus proche, appeler le 1-800-4-KOHLER (1-800-456-4537) à partir des E.-U. et du Canada, et le 001-800-456-4537 à partir du Mexique, ou consulter le site <a href="http://www.kohler.com">www.kohler.com</a> aux É.-U., <a href="http://www.ca.kohler.com">www.ca.kohler.com</a> à partir du Canada, ou <a href="http://www.mx.kohler.com">www.mx.kohler.com</a> au Mexique.</p> <p><b>KOHLER CO. ET/OU LE REVENDEUR FOURNISSENT CES GARANTIES AU LIEU ET PLACE DE TOUTES AUTRES GARANTIES, EXPRESSES OU TACITES, Y COMPRIS LES GARANTIES TACITES DE COMMERCIALITÉ ET D'ADAPTATION À UN USAGE PARTICULIER. KOHLER CO. ET/OU LE REVENDEUR DÉCLINENT TOUTE RESPONSABILITÉ CONTRE LES DOMMAGES PARTICULIERS, ACCESSOIRES OU INDIRECTS. Certains états et provinces ne permettent pas de limite sur la durée de la garantie tacite, ni l'exclusion ou la limite des dommages, et, par conséquent, lesdites limites et exclusions peuvent ne pas s'appliquer à votre cas. La présente garantie accorde au consommateur des droits juridiques particuliers. Vous pouvez également avoir d'autres droits qui varient d'un état ou d'une province à l'autre.</b></p> <p><b>Ceci constitue la garantie écrite exclusive de Kohler Co.</b></p> <p>*Les robinets Trend®, la colonne MasterShower®, les systèmes et éléments BodySpa; la colonne, les systèmes et les éléments WaterHaven®; les robinets Tripoint®, les finitions or poli, non-Vibrant et peintes ou à revêtement de poudre, les raccords, tous les articles de la section "Fixture Related" du catalogue des prix des robinets Kohler, les drains, les crépines d'évier Duostrainer®, les distributeurs de savon/lotion, le haut-parleur sans fil Moxie® et les robinets utilisés dans des installations commerciales et en dehors de l'Amérique du Nord sont couverts par la garantie limitée d'un an de Kohler Co.</p> <p>**Ne jamais utiliser de nettoyeurs contenant des agents abrasifs, de l'ammoniaque, de l'eau de Javel, des acides, des cires, de l'alcool, des dissolvants ou autres produits non recommandés pour le chrome. Ceci annulera la garantie.</p>	<p><b>Garantía limitada de por vida para la grifería KOHLER®</b></p> <p>Kohler Co. garantiza la grifería* fabricada después del 1 de enero de 1997 contra problemas de fugas y goteo durante el uso residencial normal, mientras el comprador consumidor original sea el propietario de su casa. En caso de que la grifería presente fugas o goteo durante el uso normal, Kohler Co. enviará por correo y sin ningún cargo al comprador original, el cartucho necesario para que la Grifería funcione correctamente. Esta garantía se aplica solo a la grifería Kohler instalada en los Estados Unidos de América, Canadá o México ("Norteamérica").</p> <p>Kohler Co. también garantiza todas las demás características de la grifería o accesorios ("Grifería")*, (excepto los acabados de oro, que no sean Vibrant®, o que no sean de cromo) contra defectos de material y mano de obra, durante el uso residencial normal, mientras el comprador consumidor original sea el propietario de su casa. Esta garantía se aplica solo a la grifería Kohler instalada en Norteamérica. Si se encuentra un defecto durante el uso residencial normal, Kohler Co., a su criterio, reparará, proveerá un repuesto o producto, o realizará los ajustes pertinentes. Esta garantía no cubre daños causados por accidentes, abuso o uso indebido del producto. El cuidado y la limpieza indebidos anulan la garantía**. Al presentar las reclamaciones de garantía a Kohler Co., es necesario incluir el comprobante de compra (recibo de venta original). Kohler Co. no se hace responsable de costos de mano de obra, instalación u otros costos incidentales o indirectos. En ningún caso la responsabilidad de Kohler Co. excederá el precio de compra de la grifería.</p> <p>Si la grifería se utiliza comercialmente o si se instala fuera del territorio de Norteamérica, o si el acabado es de oro, no es Vibrant o es un acabado de color con revestimiento de pintura o polvo, Kohler Co. garantiza la grifería contra defectos de material y mano de obra durante un (1) año a partir de la fecha de instalación, bajo la garantía limitada de un año estándar de Kohler Co.</p> <p>Si usted considera que tiene una reclamación en virtud de la garantía, comuníquese con Kohler Co. a través de su distribuidor, contratista de plomería, centro de remodelación o distribuidor por Internet, o escriba a Kohler Co., Attn.: Customer Care Center, 444 Highland Drive, Kohler, WI 53044, USA. Asegúrese de proporcionar toda la información pertinente a su reclamación, incluida una descripción completa del problema, el producto, el número de modelo, el color, el acabado, la fecha de compra y el lugar de compra del producto. También incluya el recibo original. Para consultar información adicional, o para obtener el nombre y la dirección del lugar de reparación y servicio más cercano a usted, llame al 1-800-4KOHLER (1-800-456-4537) en los EE.UU. y Canadá, y al 001-800-456-4537 en México, o visite <a href="http://www.kohler.com">www.kohler.com</a> en los EE.UU., <a href="http://www.ca.kohler.com">www.ca.kohler.com</a> en Canadá, o <a href="http://www.mx.kohler.com">www.mx.kohler.com</a> en México.</p> <p><b>KOHLER CO. Y/O EL VENDEDOR OFRECEN ESTAS GARANTÍAS QUE SUSTITUYEN A TODAS LAS DEMÁS GARANTÍAS, EXPRESAS O IMPLÍCITAS, INCLUIDAS, ENTRE OTRAS, LAS GARANTÍAS IMPLÍCITAS DE COMERCIALIZACIÓN E IDONEIDAD PARA UN USO DETERMINADO. KOHLER CO. Y/O EL VENDEDOR DESCARGAN TODA RESPONSABILIDAD POR CONCEPTO DE DAÑOS PARTICULARES, INCIDENTALES O INDIRECTOS. Algunos estados/algunas provincias no permiten limitaciones en cuanto a la duración de una garantía implícita o a la exclusión o limitación de dichos daños, por lo que es posible que estas limitaciones y exclusiones no se apliquen a su caso. Esta garantía otorga al consumidor ciertos derechos legales específicos. Además, usted puede tener otros derechos que varían de estado a estado y de provincia a provincia.</b></p> <p><b>Esta es la garantía exclusiva por escrito de Kohler Co.</b></p> <p>*La grifería Trend® la torre MasterShower®, los sistemas y los componentes BodySpa, la torre, los sistemas y los componentes WaterHaven®, las griferías Tripoint®, el acabado en oro pulido, que no sea Vibrant, y los acabados con revestimiento de pintura o en polvo, las conexiones, todos los artículos contenidos en la sección "Fixture Related" de la lista de precios de la grifería Kohler, los desagües, las coladeras de fregadero Duostrainer®, los dispensadores de jabón y loción, la bocina inalámbrica Moxie®; y la grifería de uso comercial e instalada fuera del territorio de Norteamérica, están cubiertos por la garantía limitada de un año de Kohler Co.</p> <p>**Nunca utilice limpiadores que contengan limpiadores abrasivos, amoníaco, blanqueador, ácidos, ceras, alcohol, disolventes u otros productos no recomendados para el cromo. Esto anulará la garantía.</p>

# KOHLER®

Installation Guide  
Guide d'installation  
Guía de instalación



Thread Sealant Tape  
Joint d'étanchéité pour filetage  
Cinta selladora de roscas

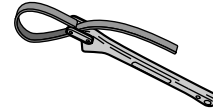

Strap Wrench  
Clé à sangle  
Llave de correa

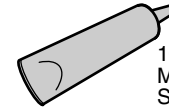

100% Silicone Sealant  
Mastic à la silicone à 100%  
Sellador 100% de silicona

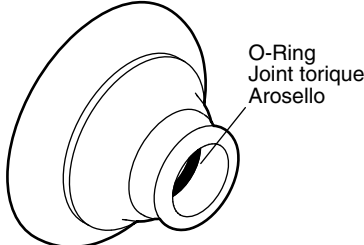
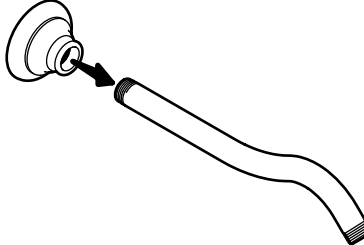
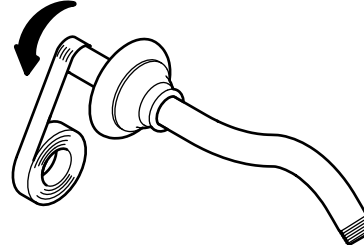
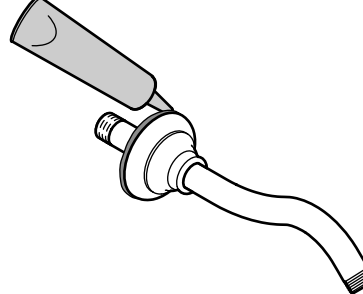
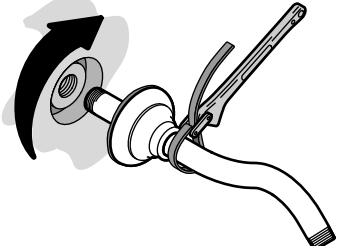
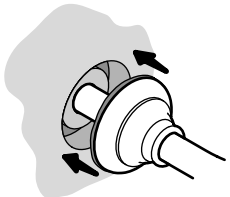
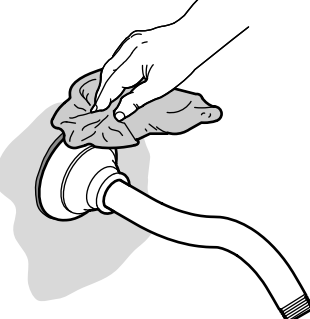
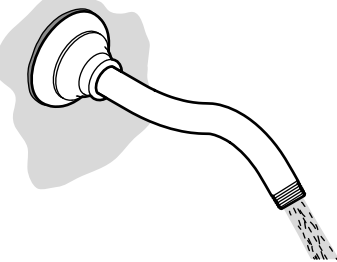

Rags  
Chiffons  
Trapos

<p><b>Record your model number below for future reference:</b> Consigner le numéro de modèle ci-dessous pour toute référence ultérieure: Apunte abajo su número de modelo para referencia futura:</p>	<p><b>Important Information</b> Observe all local codes and standards. Install the finished wall or bath/shower unit prior to installing this product.</p> <p><b>Informations importantes</b> Respecter toutes les normes et tous les codes locaux. Installer le mur fini ou l'ensemble baignoire/douche avant de poser ce produit.</p> <p><b>Información importante</b> Cumpla con todos los códigos y normas locales. Instale la pared acabada o la unidad de la bañera/ducha antes de instalar este producto.</p>	<p><b>1</b> Ensure that the O-ring is properly seated in the flange. S'assurer que le joint torique est assis correctement dans la bride. Asegúrese de que el arosello estén bien asentado en la brida.</p>  <p>O-Ring Joint torique Arosello</p>	<p><b>2</b> Slide the flange onto the shower arm. Enfiler la bride sur le bras de douche. Deslice la brida en el brazo de ducha.</p> 	<p><b>3</b> Apply sealant tape. Appliquer du ruban d'étanchéité. Aplique cinta selladora.</p> 	<p><b>4</b> Apply 100% silicone sealant around the back of the flange. Appliquer du mastic à la silicone à 100% sur l'arrière de la bride. Aplique sellador 100% de silicona alrededor del lado posterior de la brida.</p> 
<p><b>5</b> Install the shower arm. Poser le bras de douche. Instale el brazo de ducha.</p> 	<p><b>6</b> Press the flange against the wall. Appuyer sur la bride pour la pousser contre le mur. Presione la brida contra la pared.</p> 	<p><b>7</b> Wipe away any excess sealant. Essuyer tout excédent de mastic. Limpie el exceso de sellador.</p> 	<p><b>8</b> Before attaching the showerhead, run water to flush out any debris. Avant d'attacher la pomme de douche, faire couler de l'eau pour purger tous les débris. Antes de fijar la cabeza de ducha, haga correr agua para limpiar la suciedad que pueda haber.</p> 		

<p><b>SERVICE PARTS</b>  <b>For service parts information, visit your product page at <a href="http://www.kohler.com/serviceparts">www.kohler.com/serviceparts</a>.</b></p> <hr/> <p>For care and cleaning and other information go to: <a href="http://www.us.kohler.com">www.us.kohler.com</a>.</p> <p><b>KOHLER® Faucet Lifetime Limited Warranty</b></p> <p>Kohler Co. warrants its Faucets* manufactured after January 1, 1997, to be leak and drip free during normal residential use for as long as the original consumer purchaser owns his or her home. If the Faucet should leak or drip during normal use, Kohler Co. will, free of charge, mail to the purchaser the cartridge necessary to put the Faucet in good working condition. This warranty applies only to Kohler Faucets installed in the United States of America, Canada or Mexico ("North America").</p> <p>Kohler Co. also warrants all other aspects of the faucet or accessories ("Faucet")*, (except gold, non-Vibrant®, non-chrome finishes) to be free of defects in material and workmanship during normal residential use for as long as the original consumer purchaser owns his or her home. This warranty applies only to Kohler Faucets installed in North America. If a defect is found in normal residential use, Kohler Co. will, at its election, repair, provide a replacement part or product, or make appropriate adjustment. Damage to a product caused by accident, misuse, or abuse is not covered by this warranty. Improper care and cleaning will void the warranty**. Proof of purchase (original sales receipt) must be provided to Kohler Co. with all warranty claims. Kohler Co. is not responsible for labor charges, installation, or other incidental or consequential costs. In no event shall the liability of Kohler Co. exceed the purchase price of the Faucet.</p> <p>If the Faucet is used commercially or is installed outside of North America, or if the finish is gold, non-Vibrant or a painted or powder coated color finish, Kohler Co. warrants the Faucet to be free from defects in material and workmanship for one (1) year from the date the product is installed, under Kohler Co.'s standard one-year limited warranty.</p> <p>If you believe that you have a warranty claim, contact Kohler Co., either through your Dealer, Plumbing Contractor, Home Center or E-tailer, or by writing Kohler Co., Attn.: Customer Care Center, 444 Highland Drive, Kohler, WI 53044, USA. Please be sure to provide all pertinent information regarding your claim, including a complete description of the problem, the product, model number, color, finish, the date the product was purchased and from whom the product was purchased. Also include your original invoice. For other information, or to obtain the name and address of the service and repair facility nearest you, call 1-800-4-KOHLER (1-800-456-4537) from within the USA and Canada, and 001-800-456-4537 from within Mexico, or visit <a href="http://www.kohler.com">www.kohler.com</a> within the USA, <a href="http://www.ca.kohler.com">www.ca.kohler.com</a> from within Canada, or <a href="http://www.mx.kohler.com">www.mx.kohler.com</a> in Mexico.</p> <p><b>KOHLER CO. AND/OR SELLER ARE PROVIDING THESE WARRANTIES IN LIEU OF ALL OTHER WARRANTIES, EXPRESSED OR IMPLIED, INCLUDING BUT NOT LIMITED TO THE IMPLIED WARRANTIES OF MERCHANTABILITY AND FITNESS FOR A PARTICULAR PURPOSE. KOHLER CO. AND/OR SELLER DISCLAIM ALL LIABILITY FOR SPECIAL, INCIDENTAL OR CONSEQUENTIAL DAMAGES. Some states/provinces do not allow limitations of how long an implied warranty lasts or the exclusion or limitation of such damages, so these limitations and exclusions may not apply to you. This warranty gives the consumer specific legal rights. You may also have other rights that vary from state/province to state/province.</b></p> <p><b>This is Kohler Co.'s exclusive written warranty.</b></p> <p>*Trend® faucets, MasterShower® tower, BodySpa systems and components; WaterHaven® tower, systems and components; Tripoint® faucets, Polished Gold, non-Vibrant and painted or powder coated finishes, fittings; all items within the "Fixture Related" section of the Kohler Faucets Price Book, drains, Duostrainer® sink strainers, soap/lotion dispensers, Moxie™ Wireless Speaker; and faucets used in commercial settings, and outside North America, are covered by Kohler Co.'s one-year limited warranty.</p> <p>**Never use cleaners containing abrasive cleansers, ammonia, bleach, acids, waxes, alcohol, solvents or other products not recommended for chrome. This will void the warranty.</p> <p>USA/Canada: 1-800-4KOHLER  Mexico: 001-800-456-4537  <a href="http://www.kohler.com">www.kohler.com</a></p>	<p><b>PIÈCES DE RECHANGE</b>  <b>Pour tout renseignement sur les pièces de rechange, visiter la page du produit à <a href="http://www.kohler.com/serviceparts">www.kohler.com/serviceparts</a>.</b></p> <hr/> <p>Pour tout renseignement sur l'entretien, le nettoyage et autre, visiter: <a href="http://www.us.kohler.com">www.us.kohler.com</a>.</p> <p><b>Garantie limitée à vie du robinet KOHLER®</b></p> <p>Kohler Co. garantit que les robinets* fabriqués après le 1er janvier 1997 ne fuient pas et ne gouttent pas lors d'une utilisation domestique normale, aussi longtemps que l'acquéreur d'origine demeure propriétaire de son domicile. Si le robinet goutte ou présente des fuites lors d'une utilisation normale, Kohler Co. enverra par courrier à l'acheteur, sans frais, la cartouche nécessaire pour réparer le robinet. La présente garantie s'applique uniquement aux robinets Kohler installés aux États-Unis, au Canada ou au Mexique ("Amérique du Nord").</p> <p>Kohler Co. garantit également toutes les autres caractéristiques du robinet ou des accessoires ("Robinet")*, (à l'exception des finitions dorées, non-Vibrant®, non chromées) contre tout vice de matériau et de fabrication lors d'une utilisation domestique normale, aussi longtemps que l'acquéreur d'origine demeure propriétaire de son domicile. La présente garantie s'applique uniquement aux robinets Kohler installés en Amérique du Nord. Si un vice est décelé lors d'une utilisation domestique normale, Kohler Co. choisira, à sa discrétion, la réparation, le remplacement ou la rectification appropriée. Cette garantie n'offre pas de protection contre les dommages dus à un accident, une mauvaise utilisation ou un mauvais traitement. Un entretien et un nettoyage inadéquats annulent la garantie**. Une preuve d'achat (ticket de caisse d'origine) doit être présentée à Kohler Co. avec toutes les réclamations au titre de la garantie. Kohler Co. n'est pas responsable des frais de main-d'œuvre, d'installation ou de tout autre frais particulier, accessoire ou indirect. La responsabilité de Kohler Co. ne dépassera en aucun cas le prix d'achat du robinet.</p> <p>Si le robinet est utilisé dans un commerce ou s'il est installé en dehors d'Amérique du Nord, ou si la finition est dorée, non-Vibrant, peinte ou revêtue d'une poudre, Kohler Co. garantit le robinet contre tout vice de matériau et de fabrication pendant un (1) an à partir de la date d'installation du produit, selon les modalités de la garantie limitée standard d'un an de Kohler Co.</p> <p>Pour toute réclamation au titre de la présente garantie, contacter Kohler Co. par l'intermédiaire du vendeur, plombier, centre de rénovation ou revendeur par internet, ou bien par écrit à l'adresse suivante Kohler Co., Attn.: Customer Care Center, 444 Highland Drive, Kohler, WI 53044, USA. Fournir tous les renseignements pertinents à la réclamation, dont notamment une description complète du problème et du produit, le numéro de modèle, la couleur, la finition, la date et le lieu d'achat du produit. Joindre également l'original de la facture. Pour de plus amples renseignements ou pour obtenir les coordonnées du service d'entretien et de réparation le plus proche, appeler le 1-800-4-KOHLER (1-800-456-4537) depuis les É.-U. et le Canada et le 001-800-456-4537 depuis le Mexique, ou visiter <a href="http://www.kohler.com">www.kohler.com</a> aux É.-U., <a href="http://www.ca.kohler.com">www.ca.kohler.com</a> au Canada ou <a href="http://www.mx.kohler.com">www.mx.kohler.com</a> au Mexique.</p> <p><b>KOHLER CO. ET/OU LE REVENDEUR FOURNISSENT CES GARANTIES AU LIEU ET PLACE DE TOUTES AUTRES GARANTIES, EXPRESSES OU TACITES, Y COMPRIS LES GARANTIES TACITES DE COMMERCIALITÉ ET D'ADAPTATION À UN USAGE PARTICULIER. KOHLER CO. ET/OU LE REVENDEUR DÉCLINENT TOUTE RESPONSABILITÉ CONTRE LES DOMMAGES PARTICULIERS, ACCESSOIRES OU INDIRECTS. Certains états et provinces ne permettent pas de limite sur la durée de la garantie tacite, ni l'exclusion ou la limite des dommages, et, par conséquent, lesdites limites et exclusions peuvent ne pas s'appliquer à votre cas. La présente garantie accorde au consommateur des droits juridiques particuliers. Vous pouvez également avoir d'autres droits qui varient d'un état ou d'une province à l'autre.</b></p> <p><b>Ceci constitue la garantie écrite exclusive de Kohler Co.</b></p> <p>*Les robinets Trend®, la colonne MasterShower®, les systèmes et éléments BodySpa; la colonne, les systèmes et les éléments WaterHaven®; les robinets Tripoint®; les finitions or poli, non-Vibrant et peintes ou à revêtement de poudre, les raccords; tous les articles de la section "Fixture Related" du catalogue des prix des robinets Kohler, les drains, les crépines d'évier Duostrainer®, les distributeurs de savon/lotion, le haut-parleur Moxie™ sans fil; et les robinets utilisés dans des milieux commerciaux et hors de l'Amérique du Nord, sont couverts par la garantie limitée d'un an de Kohler Co.</p> <p>**Ne jamais utiliser de nettoyants contenant des agents abrasifs, de l'ammoniac, de l'eau de Javel, des acides, des cires, de l'alcool, des dissolvants ou autres produits non recommandés pour le chrome. Ceci annulera la garantie.</p>	<p><b>PIEZAS DE REPUESTO</b>  <b>Para información sobre piezas de repuesto, visite la página de su producto en <a href="http://www.kohler.com/serviceparts">www.kohler.com/serviceparts</a>.</b></p> <hr/> <p>Para el cuidado y la limpieza y otra información visite: <a href="http://www.us.kohler.com">www.us.kohler.com</a>.</p> <p><b>Garantía limitada de por vida para la grifería KOHLER®</b></p> <p>Kohler Co. garantiza que la Grifería* fabricada después del 1 de enero de 1997 está libre de problemas de fugas y goteo durante el uso residencial normal, mientras el comprador consumidor original sea el propietario de su casa. En caso de que la Grifería presente fugas o goteo durante el uso normal, Kohler Co. enviará por correo y sin ningún cargo al comprador original, el cartucho necesario para que la Grifería funcione correctamente. Esta garantía se aplica sólo a la Grifería Kohler instalada en los Estados Unidos de América, Canadá o México ("Norteamérica").</p> <p>Kohler Co. también garantiza que todas las demás características de la grifería o accesorios ("Grifería")*, (excepto los acabados de oro, que no sean Vibrant®, o que no sean de cromo) están libres de defectos de material y mano de obra, durante el uso residencial normal, mientras el comprador consumidor original sea el propietario de su casa. Esta garantía se aplica sólo a la Grifería Kohler instalada en Norteamérica. Si se encuentra un defecto durante el uso residencial normal, Kohler Co., a su criterio, reparará, proveerá un repuesto o producto, o realizará los ajustes pertinentes. Esta garantía no cubre daños causados por accidente, abuso o uso indebido del producto. El cuidado y la limpieza indebidos anularán la garantía**. Al presentar las reclamaciones de garantía a Kohler Co., es necesario incluir la prueba de compra (recibo de venta original). Kohler Co. no se hace responsable de costos de mano de obra, instalación u otros costos incidentales o indirectos. En ningún caso la responsabilidad de Kohler Co. excederá el precio de compra de la Grifería.</p> <p>Si la Grifería se utiliza comercialmente o se instala fuera del territorio de Norteamérica, o si el acabado es de oro, no es Vibrant o un acabado de color con revestimiento de pintura o polvo, Kohler Co. garantiza que la Grifería está libre de defectos de material y mano de obra por un (1) año, a partir de la fecha de instalación, bajo la garantía limitada de un año estándar de Kohler Co.</p> <p>Si usted considera que tiene una reclamación en virtud de la garantía, comuníquese con Kohler Co. a través de su distribuidor, contratista de plomería, centro de remodelación o distribuidor por Internet, o escriba a Kohler Co., Attn.: Customer Care Center, 444 Highland Drive, Kohler, WI 53044, USA. Por favor, asegúrese de proporcionar toda la información pertinente a su reclamación, incluyendo una descripción completa del problema, el producto, el número de modelo, el color, el acabado, la fecha de compra y el lugar de compra del producto. También incluya el recibo original. Para información adicional, o para obtener el nombre y dirección del lugar de reparación y servicio más cercano a usted, llame al 1-800-4-KOHLER (1-800-456-4537) desde los EE.UU. y Canadá, y al 001-800-456-4537 desde México, o visite <a href="http://www.kohler.com">www.kohler.com</a> desde los EE.UU., <a href="http://www.ca.kohler.com">www.ca.kohler.com</a> desde Canadá, o <a href="http://www.mx.kohler.com">www.mx.kohler.com</a> en México.</p> <p><b>KOHLER CO. Y/O EL VENDEDOR OFRECEN ESTAS GARANTÍAS QUE SUSTITUYEN TODAS LAS DEMÁS GARANTÍAS, EXPRESAS O IMPLÍCITAS, INCLUYENDO, ENTRE OTRAS, LAS GARANTÍAS IMPLÍCITAS DE COMERCIALIZACIÓN E IDONEIDAD PARA UN USO DETERMINADO. KOHLER CO. Y/O EL VENDEDOR DESCARGAN TODA RESPONSABILIDAD POR CONCEPTO DE DAÑOS PARTICULARES, INCIDENTALES O INDIRECTOS. Algunos estados/provincias no permiten limitaciones en cuanto a la duración de una garantía implícita o a la exclusión o limitación de dichos daños, por lo que estas limitaciones y exclusiones pueden no aplicar a su caso. Esta garantía otorga al consumidor ciertos derechos legales específicos. Además, usted puede tener otros derechos que varían de estado a estado y provincia a provincia.</b></p> <p><b>Ésta es la garantía exclusiva por escrito de Kohler Co.</b></p> <p>*La grifería Trend®, la torre MasterShower®, los sistemas y componentes BodySpa®, la torre, sistemas y componentes WaterHaven®, las griferías Tripoint®, el acabado en oro pulido, que no sea Vibrant y los acabados con revestimiento de pintura o en polvo, las conexiones, todos los artículos contenidos en la sección "Fixture Related" de la lista de precios de la grifería Kohler, los desagües, las coladeras de fregadero Duostrainer®, los dispensadores de jabón y loción, la bocina inalámbrica Moxie™; y la grifería de uso comercial e instalada fuera del territorio de Norteamérica, están cubiertos por la garantía limitada de un año de Kohler Co.</p> <p>**Nunca utilice limpiadores que contengan limpiadores abrasivos, amoníaco, blanqueador, ácidos, ceras, alcohol, disolventes u otros productos no recomendados para el cromo. Esto anulará la garantía.</p>
--	---	--