

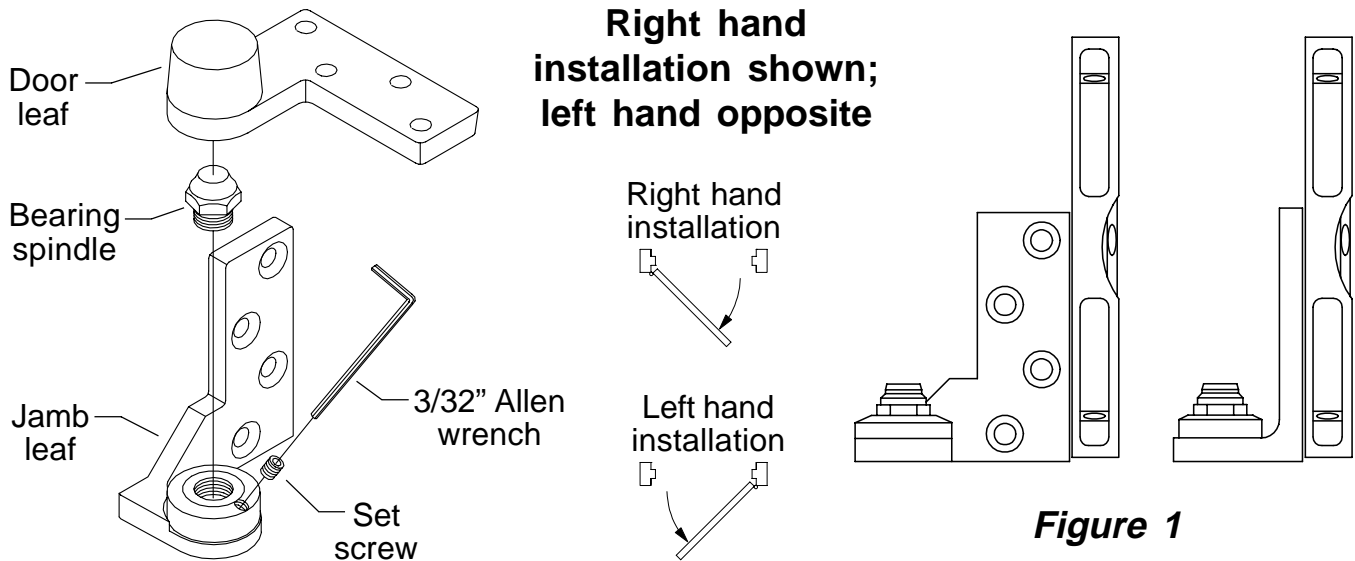

Installation Instructions

7212

3/4" Offset Jamb Mounted Bottom Pivot



1. Prepare and mortise bottom of door and side jamb to receive pivot set. Determine pivot location using dimensions on reverse side. **Be sure to properly locate and mark center point of the jamb leaf spindle.** Care must be taken to ensure that jamb leaf is completely level. Place level against jamb leaf surfaces as shown in Figure 1. The bottom pivot set is handed. Hand of pivot must match hand of door. To determine hand of door, see diagrams above.
2. Locate, drill, and tap 1/4-20 mounting holes for metal door or metal frame. Locate and drill pilot holes for #14 wood screws for wood door or wood frame. Mount jamb leaf to side jamb and door leaf in bottom of door with 1/4-20 x 3/4" FHMS or #14 FHWS screws provided.
3. At this point, the top pivot of the set should be installed. After top pivot installation, hang door. Refer to instruction sheet packed with top pivot for details.
4. If height adjustment is necessary for proper door clearance, adjust bottom pivot as follows:
 - A. Remove top pivot pin and take door down.
 - B. Use 3/32" Allen wrench provided to loosen set screw in jamb leaf (see diagram above).
 - C. Adjust bearing spindle height with 5/8" Allen wrench. Range is plus 1/8", minus 1/16".
 - D. Re-install door.



CAUTION

Improper pivot set installation can lead to personal injury or property damage. Follow all instructions carefully. For questions contact Technical Support at 1-888-371-7331.



NOTE

It is very important for installer to verify that center line of top pivot point lines up with center line of bottom pivot point before final installation. Heel edge of door must be beveled $1/8''$ in $2''$ as shown below. The bottom pivot set should be mounted first in most installations.

*Depth of mortise will vary depending upon installation and/or threshold height.

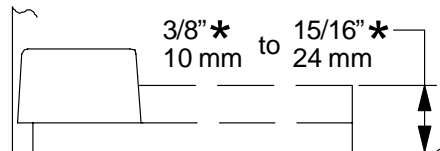

Bevel heel edge of door
 $1/8''$ in $2''$ with $3/16''$ rad, typ

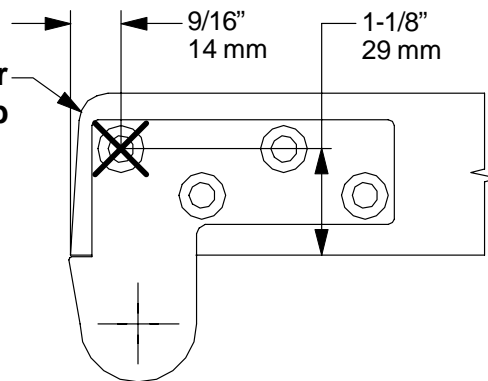

Door Leaf

Face of door

$3/4''$
19 mm

$1-3/8''$
35 mm

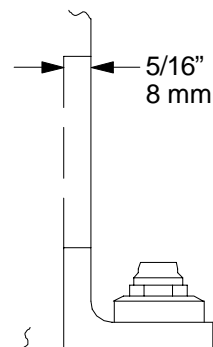
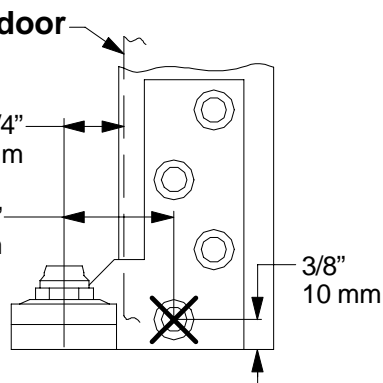

Frame Leaf

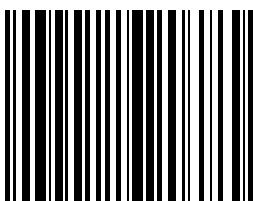

16000