

# Assembly & Installation Instructions

**A303**

Corona Adjustable Pendant 13-6501

Page 1 of 3

**CAUTION: FAILURE TO INSTALL THIS FIXTURE PROPERLY MAY RESULT IN SERIOUS PERSONAL INJURY OR DEATH AND PROPERTY DAMAGE. We recommend installation by a licensed electrician.**

This product must be installed in accordance with applicable installation code(s), by a person familiar with the construction and operation of the product and the hazards involved.\*

**Caution:** Do not exceed maximum wattage noted on fixture. Use only recommended bulbs with fixture.

## Stem Assembly (Figure 1)

### Component Parts

- K Fixture Pipe
- L Fixture Coupling

1. Carefully unpack the fixture from the carton.
2. Carefully thread fixture pipe (K), threaded end first, over fixture wires and support cable.
3. Apply a drop of the supplied thread locking compound to the internal threads of fixture coupling (L) and screw stem into fixture, being careful not to twist or pinch the wires.  
**Note:** Application of the thread locking compound is necessary to prevent the stem from loosening during regular maintenance and cleaning of the fixture. Be certain to apply the compound.
4. See instructions below to complete the installation.

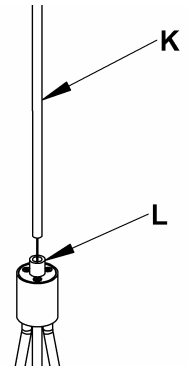

(Figure 1)

## Prepare the Canopy (Figure 2)

### Component Parts

- B Crossbar
- D Jam Nut
- E Threaded Nipple
- F Canopy
- G Canopy Ring

**Caution:** Be sure power is off at the main breaker box prior to installation.

1. Thread jam nut (D) and crossbar (B) onto threaded nipple (E); leave both parts loose.
2. Using two machine screws (not provided), temporarily fasten the crossbar (B) to the electric box. **Note:** A new electric box comes with screws. When replacing a fixture, retain the existing screws for use with the new fixture.
3. Adjust the length of threaded nipple (E) in crossbar (B) so that canopy ring (G) will hold canopy (F) against the ceiling with no threads showing for best appearance. When the correct adjustment is established, tighten jam nut (D) against crossbar (B) to hold the adjustment.
4. Remove the crossbar and stem from the electrical box and proceed with the assembly instructions.

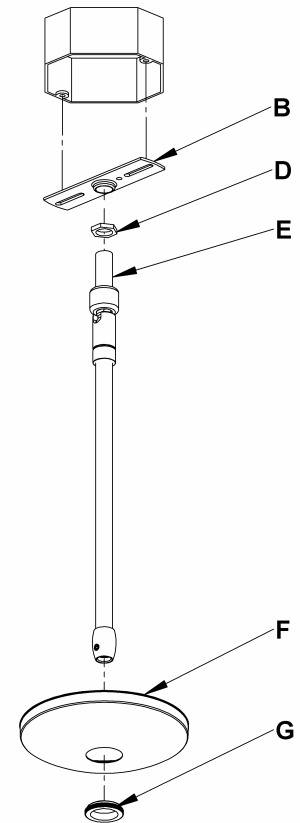

(Figure 2)

(continued)

# Assembly & Installation Instructions

Corona Adjustable Pendant 13-6501

**A303**

Page 2 of 3

## Complete Assembly & Install Fixture (Figures 3, 4 & 5)

### Component Parts

A	Support Cable	G	Canopy Ring
B	Crossbar	H	Large Diameter Pipe
C	Cable Gripper	I	Plastic Sleeve
D	Jam Nut	J	Clutch
E	Threaded Nipple	K	Small Diameter Pipe
F	Canopy		

**Caution: Be sure power is off at the main breaker box prior to installation.**

1. Place canopy (F) over canopy pipe (H), followed by canopy ring (G). Make sure smaller diameter side of canopy ring is oriented up toward the canopy.
2. Thread wires and support cable (A) from the fixture pipe (K) through the canopy pipe (H).
3. Unscrew the clutch (J) from the canopy pipe (H); slide it across the wires and onto the fixture pipe (K). Follow this with the plastic clutch sleeve (I), oriented so the tapered end of the clutch sleeve nests in the clutch. (Figure 3).
4. Slide the canopy pipe (H) as far as necessary to give you the total length of the fixture which you desire. Be careful not to scratch the pipe surfaces and to pull excess wire up through the canopy pipe (H). There must be a minimum 1-1/2" of inner pipe inside the outer pipe. Hand-tighten the clutch to temporarily hold this adjustment. The clutch is not securely fastened at this point; do not depend on it to hold the fixture. **Important:** To ensure full connection strength, be sure the tapered end of the plastic clutch sleeve (I) is oriented toward the clutch (J) when assembled and securely tighten set screw (Figure 3).
5. Carefully slide canopy ring (G) and canopy (F) down over fixture pipe (K) until they rest on the fixture.
6. Using two machine screws (not provided), fasten the crossbar to the electric box. **Note: A new electric box comes with screws. When replacing a fixture, retain the existing screws for use with the new fixture.**
7. Thread support cable (A) through holes in crossbar (B) and push into cable gripper (C) until cable is tight and has no slack. Once support cable is at the correct height, excess cable behind the gripper can be cut off (Figure 5, next page).
8. Using suitable wire connectors (not provided), connect fixture wires to supply wires (white to white supply, black to black supply, and bare copper to bare copper or green supply). Run a pigtail lead from crossbar (A) green ground screw to the junction box and connect all ground wires (bare copper or green to bare copper or green). Push wires back into outlet box. **Caution: Make sure wire connectors are twisted on securely, and no bare wire is exposed.**
9. Slide fixture canopy (F) against ceiling, and secure with canopy ring (G).

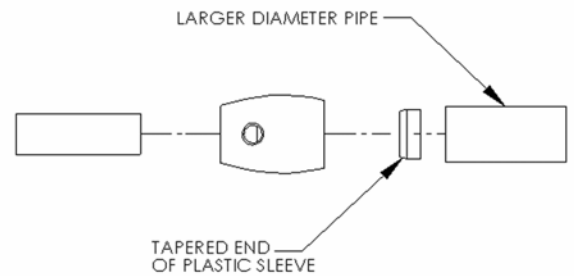

(Figure 3)

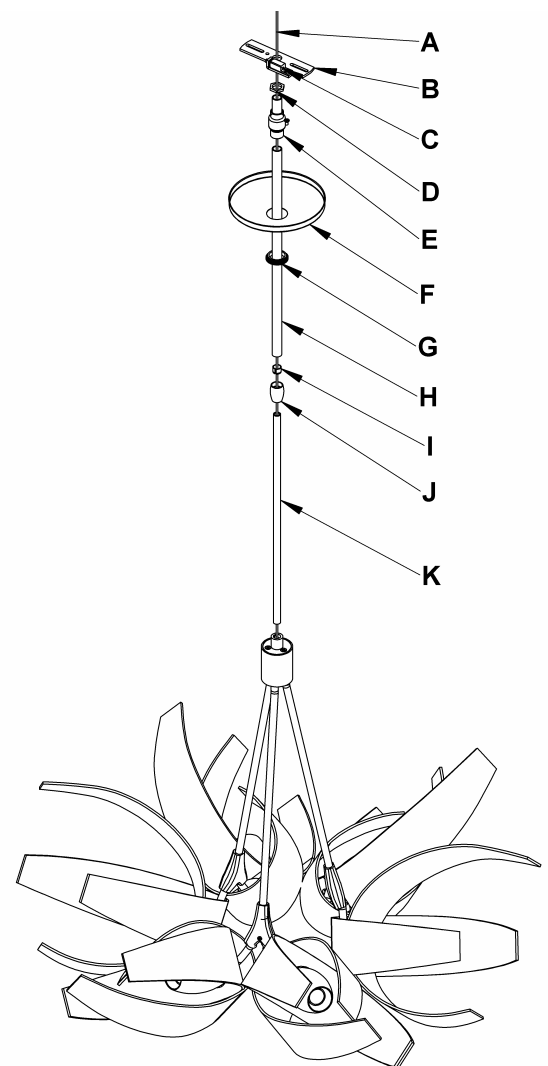

(Figure 4)

(continued)

10. Once the fixture is fastened to the ceiling, tighten the set screw on the clutch (J) firmly with hex wrench provided. Only after the set screw is tight should you install the glass.

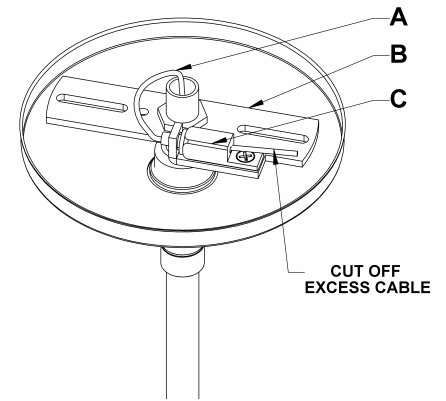

(Figure 5)

## Install Glass (Figure 6)

### Component Parts

- M Socket (6)
- N Bulb (6-included)
- O Glass (6)

1. Install light bulb (N). Be careful not to touch bulb with bare hands; oil from the hands will dramatically reduce bulb life. **Note:** The bulb included is based on our design preference; see the fixtures wattage sticker for Max wattage information.
2. Slip glass (O), over socket (M) and thread until snug against socket. *Be careful not to over tighten.*
3. Restore electricity at the main breaker.

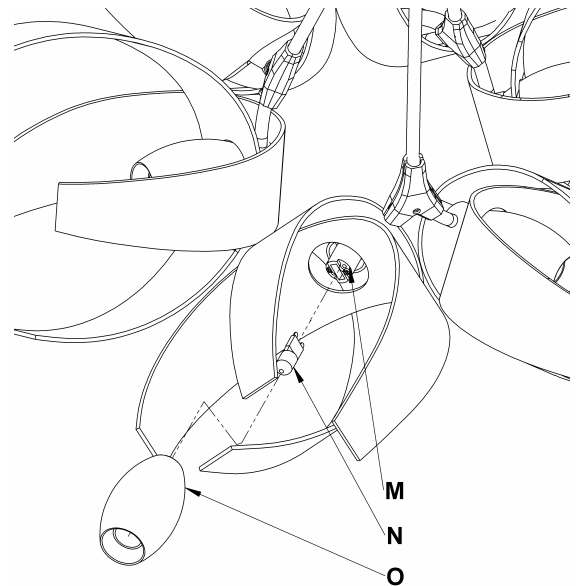

(Figure 6)

*If you need further assistance, or find that you are missing any parts, please contact the dealer from which you purchased this product. We hope you enjoy your fixture!*

\* Hubbardton Forge will not be liable for injury or damage caused by improper installation, lamping or use of this fixture.