

Installation Instructions

For Antasia Foyer Pendant 12-1013

A290

Page 1 of 2

CAUTION: FAILURE TO INSTALL THIS FIXTURE PROPERLY MAY RESULT IN SERIOUS PERSONAL INJURY OR DEATH AND PROPERTY DAMAGE. We recommend installation by a licensed electrician.

This product must be installed in accordance with applicable installation code(s), by a person familiar with the construction and operation of the product and the hazards involved.*

Caution: Do not exceed maximum wattage noted on fixture. Use only recommended bulbs with fixture.

To Install the Canopy (Figure 1)

Component Parts

A	Ground Screw	E	Canopy
B	Crossbar	F	Canopy Loop
C	Lock Nut	G	Loop Collar
D	Nipple	H	Fixture Loop

Caution: Be sure power is off at the main breaker box prior to installation

1. Carefully unpack the fixture from the carton.
2. Using two machine screws (not provided), fasten the crossbar (B) to the electric box (see illustration).

Note: A new electric box comes with screws. When replacing a fixture, retain the existing screws for use with the new fixture.

3. Thread the nipple (D) into the crossbar (B) and secure with lock nut (C); slide canopy (E) over nipple (D), and attach the canopy loop (F) to the nipple (D). Adjust the nipple to proper length to ensure a snug canopy fit before proceeding.
4. Attach one end of the chain to the fixture loop (H). Lace the wire through every other link of the chain to the end. Slip wires and chain through the collars and canopy (G, F & E). Fasten the chain to the canopy loop (F), slip wires through the loop and nipple into the electric box. Make sure to provide enough slack in the wire to ensure weight of fixture is supported by the chain.
5. Using suitable wire connectors (not provided) connect fixture wires to supply wires (white to ribbed side of the fixture s cord, black to smooth side). Connect all ground wires to crossbar ground screw (A).
6. Raise canopy (E) to the ceiling and secure loop collar (G) to canopy loop (F).

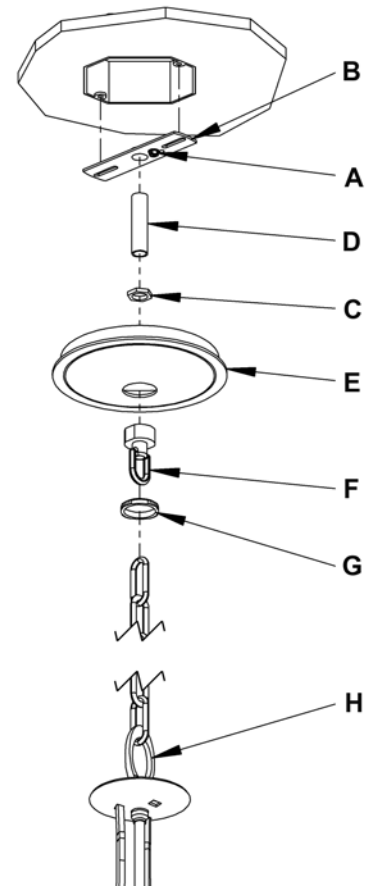

(Figure 1)

(continued)

Installation Instructions

For Antasia Foyer Pendant 12-1013

A290

Page 2 of 2

To Install Inner Glass (Figure 2)

Component Parts

- I Socket
- J Inner Glass
- K Retaining Ring

1. Remove retaining ring (K) from socket (I). *Retaining Ring is shipped installed.*
2. Place inner glass (J) over socket (I).
3. Replace retaining ring (K) and tighten to secure glass. *Do not over-tighten.*
4. Install light bulb. *Not Included*

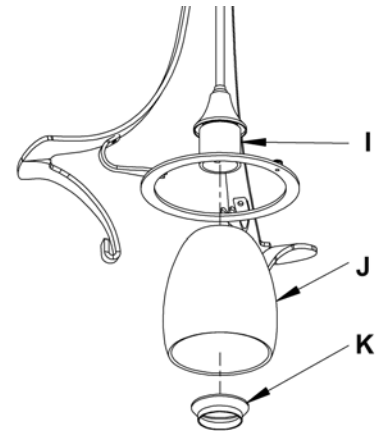

(Figure 2)

To Install Outer Glass (Figure 3)

Component Parts

- L Arm Retaining Ring
- M Stationary Arm (2)
- N Loose Arm
- O Outer Glass
- P Thumb Screw

1. Loosen arm retaining ring (L).
2. Loosen thumb screw (P).
3. Insert loose arm (N) into notches by angling the arm so it slips into notch and pivoting toward the center until it hangs vertical.
4. Move loose arm (N) out to allow outer glass (O) to rest on the two stationary arms (M).
5. While supporting the outer glass (O) move loose arm (N) in towards the center of the fixture until the outer glass (O) rests on all three arms.
6. While supporting the glass align slot in the loose arm (N) with thumb screw (P) and tighten.
Caution: Arm can swing out causing glass to drop until thumb screw is completely tight.
7. Tighten arm retaining ring (L) until snug.
8. Restore electricity at main breaker.

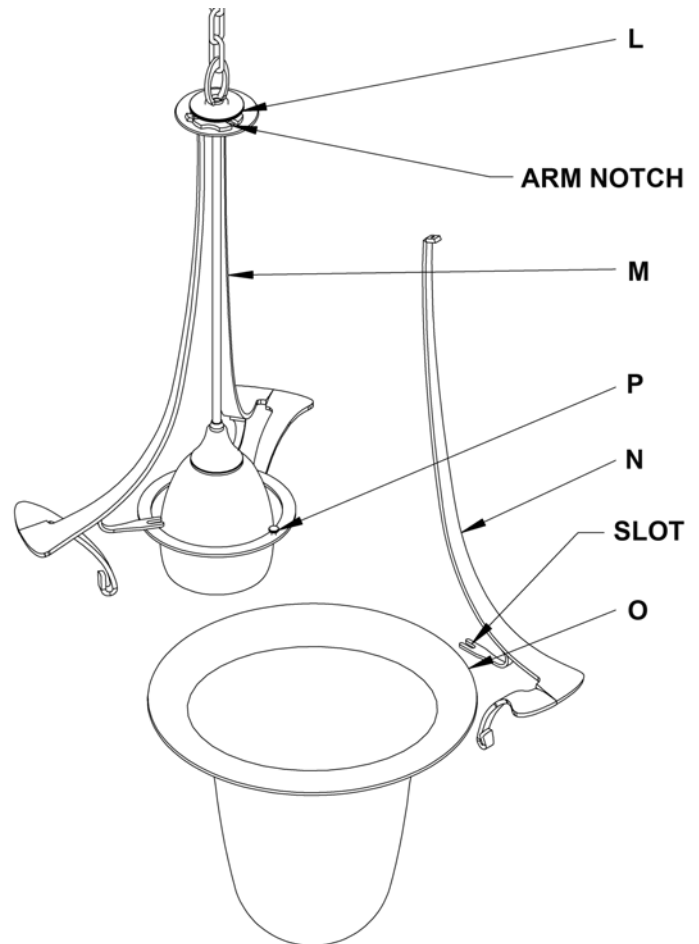

(Figure 3)

If you need further assistance, or find that you are missing any parts, please contact the dealer from which you purchased this product. We hope you enjoy your fixture!

* Hubbardton Forge will not be liable for injury or damage caused by improper installation, lamping or use of this fixture.