

**SCHOCK ◀ HOUZER**  
**Topmount Large Single Bowl**  
**Model Montano N-100XL**



Montano N-100XL

**FEATURES**

- **CRISTADUR®**
- 9-1/2" depth • Pre-scored up to 5 faucet holes
- Inherently hygienic Non-porous surface
- Antibacterial protection with silver ion Antibac®
- Silky to the touch, 3 times harder than natural granite
- Food-safe, UV-stable-will not fade
- Heat resistance to +500°F
- Highest resistance to thermal shock, scratches and chips
- Color-fast throughout
- Fits 36" sink base • cUPC listed
- Supplied with cutout template, fasteners and instructions
- Lifetime Limited Warranty



**OPTIONAL ACCESSORIES**

- Bottom Grid: 629705
- Wire Tray: WT-3500
- Strainer Options: Stainless steel strainers, Color strainers, Color Disposal flanges

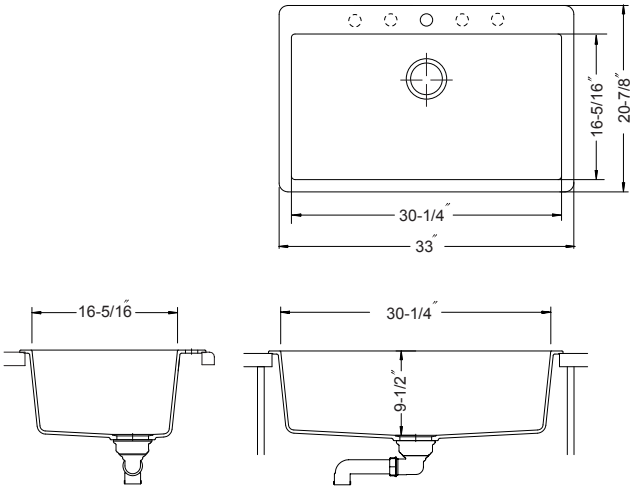

OVERALL DIMENSIONS	EACH BOWL	CUTOUT SIZE	PACKAGING*	WEIGHT*
33" x 20-7/8"	30-1/4" x 16-5/16"	See Template	1/10 pcs.	48/520lbs.

\*Standard packaging: Single boxed /Pallet of single boxed.  
All dimensions are in inches. Specifications subject to change without notice.

**Available Colors**



Project/Job name  
Architect/Engineer  
Contractor  
Model  
Notes

Q'ty