

MOUNTING TEMPLATE FOR 1549

1. TAPE TEMPLATE IN LOCATION WHERE FIXTURE IS TO BE MOUNTED.
2. USING A $3/32$ " DIAMETER DRILL. DRILL TO HOLES AT POINTS INDICATED.
3. USING PAN HEAD WOOD SCREWS. SCREW THEM IN UNTIL THE BASE OF THE SCREW HEAD IS $3/16$ " FROM MOUNTING SURFACE (SEE SKETCH).

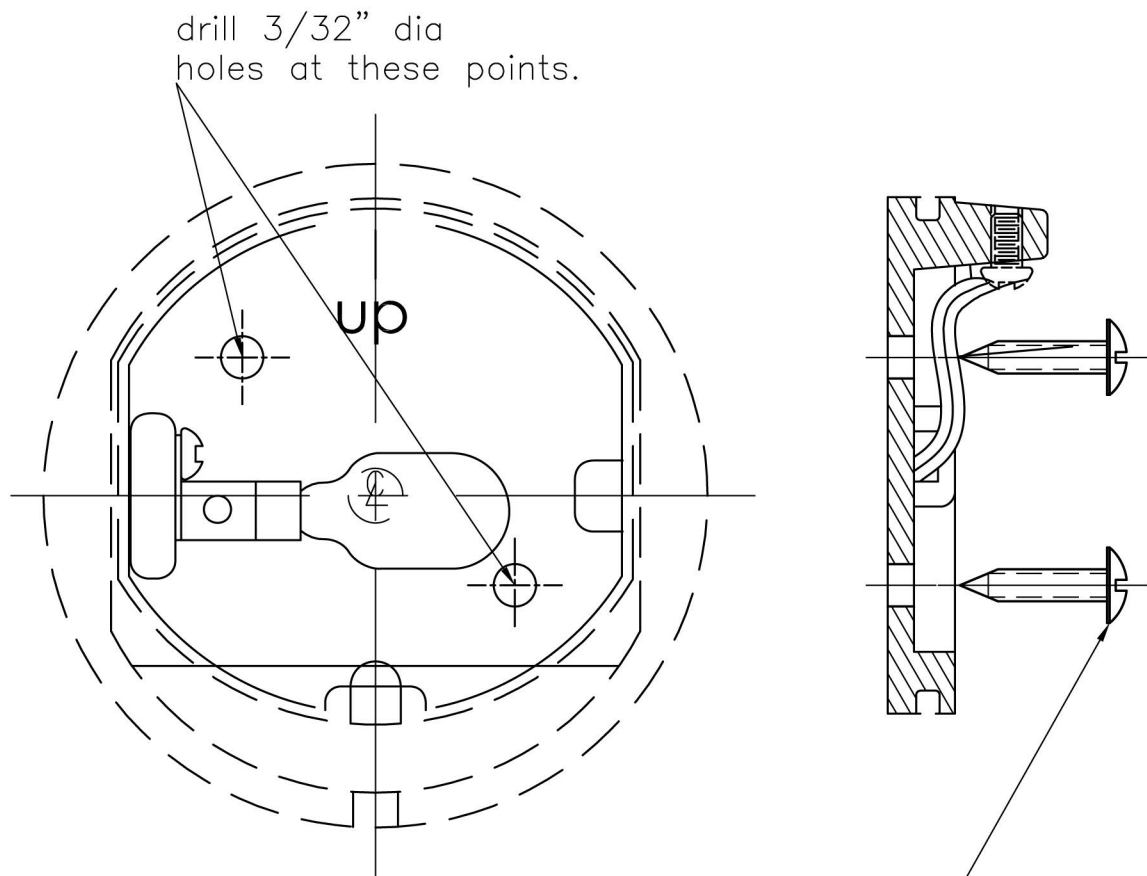

#8 PAN HEAD WOOD SCREW
 $3/4$ " LONG (2) Reqd.



HINKLEY[®]
AFTERHOURS

design • illuminate • enjoy