

Drawing 1 - Fixture Assembly

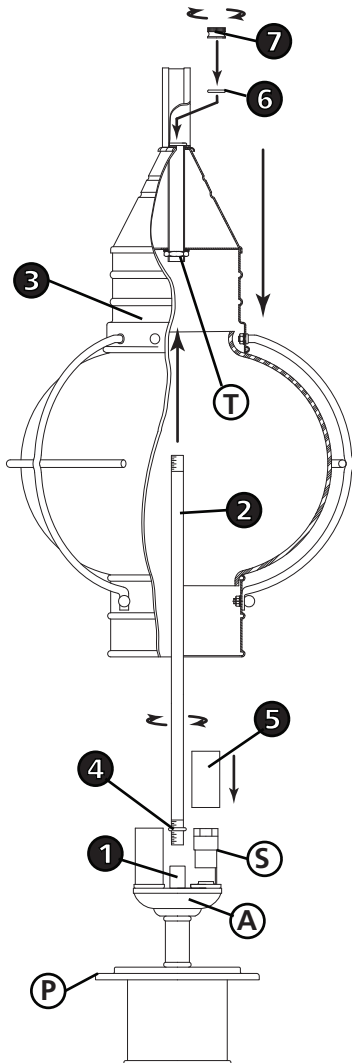

Item No. 2201 / 2207

▼ start here

1

1. Find a clear area in which you can work.
2. Unpack fixture and glass from carton.
3. Carefully review instructions prior to assembly.

***The construction of this fixture will be accomplished by first assembling main body of the fixture, making all necessary electrical connections, and then mounting the fixture to pre-installed post.

2

1. To assembly main fixture body, first thread center stem (2) into couple (1) located in the center of the socket assembly (A). Thread stem in approximately 3/8" - see Drawing 1.
2. Next slip center stem (2) through tube (T) in the top of the cage assembly (3). Slip cage assembly down until bottom of cage assembly rests on plate (P).
3. Check to make sure center stem (2) extends past the end of tube (T), in top of cage, assembly approximately 1/4". Remove cage assembly and thread center stem (2) up or down until it is at the proper height.
4. After center stem (2) is adjusted properly, it can be locked in place by threading smooth nut (4) down onto coupler (1).
5. Next slip candle sleeves (5) over sockets (S).
6. Main fixture body can now be installed on post, see instructions below.

SAFETY WARNING: READ WIRING AND GROUNDING INSTRUCTIONS (I.S. 18) AND ANY ADDITIONAL DIRECTIONS. TURN POWER SUPPLY OFF DURING INSTALLATION. IF NEW WIRING IS REQUIRED, CONSULT A QUALIFIED ELECTRICIAN OR LOCAL AUTHORITIES FOR CODE REQUIREMENTS.

3

3. Make electrical connections from supply wire to fixture lead wires. Refer to instruction sheet (I.S. 18) and follow all instructions to make all necessary wiring connections.

4

1. Slip post fitter (A) over top of pre-installed post (B) - see Drawing 2.
2. Using the holes in the side of the post fitter as guides, drill three 1/16" diameter holes in the pole.
3. Now screw in the three sheet metal screws (C).

1. After fixture is attached to installed pole. Lamp fixture accordingly and then slip cage assembly (3) onto center stem (2).
2. To secure cage assembly (3) to fixture body, first slip rubber washer (6) onto center stem (2) and then thread on top knob (7) and tighten to secure assembly.

Drawing 2 - Fixture Mounting

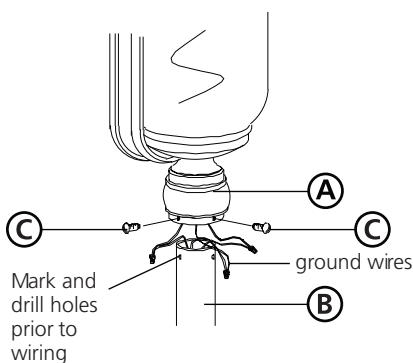

Drawing 1 - Flush Mount



Drawing 2 - Chain Hung



Drawing 3 - Post-Mount



SAFETY WARNING: READ WIRING AND GROUNDING INSTRUCTIONS (I.S. 18) AND ANY ADDITIONAL DIRECTIONS. TURN POWER SUPPLY OFF DURING INSTALLATION. IF NEW WIRING IS REQUIRED, CONSULT A QUALIFIED ELECTRICIAN OR LOCAL AUTHORITIES FOR CODE REQUIREMENTS.

wiring instructions

Indoor Fixtures

1. Connect positive supply wire **(A)** (typically black or the smooth, unmarked side of the two-conductor cord) to positive fixture lead **(B)** with appropriately sized twist on connector - see **Drawings 1 or 2**.
2. Connect negative supply wire **(C)** (typically white or the ribbed, marked side of the two-conductor cord) to negative fixture lead **(D)**.
3. Please refer to the **grounding instructions** below to complete all electrical connections.

Outdoor Fixtures

1. Connect positive supply wire **(A)** (typically black or the smooth unmarked side of the two-conductor cord) to positive fixture lead **(B)** with appropriately sized twist on connector - see **Drawings 2 or 3**.
2. Connect negative supply wire **(C)** (typically white or the ribbed, marked side of the two-conductor cord) to negative fixture lead **(D)**.
3. Cover open end of connectors with silicone sealant to form a watertight seal.
 - If installing a wall mount fixture, use caulk to seal gaps between the fixture mounting plate (backplate) and the wall. This will help prevent water from entering the outlet box. If the wall surface is lap siding, use caulk and a fixture mounting platform specially.
4. Please refer to the **grounding instructions** below to complete all electrical connections.

grounding instructions

Flush Mount Fixtures

For positive grounding in a 3-wire electrical system, fasten the fixture ground wire **(E)** (typically copper or green plastic coated) to the fixture mounting strap **(1)** with the ground screw **(2)** - see **Drawing 1**.

Note: On straps for screw supported fixtures, first install the two mounting screws in strap. Any remaining tapped hole may be used for the ground screw.

Chain Hung Fixtures

Loop fixture ground wire **(E)** (typically copper or green plastic coated) under the head of the ground screw **(2)** on fixture mounting strap **(1)** and connect to the loose end of the fixture ground wire directly to the ground wire of the building system with appropriately sized twist-on connectors - see **Drawing 2**.

Post-Mount Fixtures

Connect fixture ground wire **(E)** (typically copper or green plastic coated) to power supply ground with appropriately sized twist-on connector inside post. Cover open end of connector with silicone sealant to form a watertight seal - see **Drawing 3**.