

Installation Instructions / Warranty

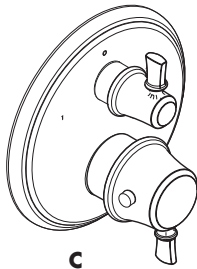

C
04221xx0

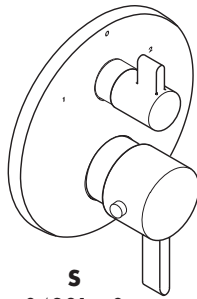

S
04231xx0

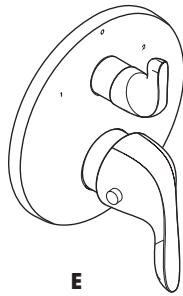

E
04226xx0

hansgrohe

Trim, Thermostat with Volume Control / Diverter

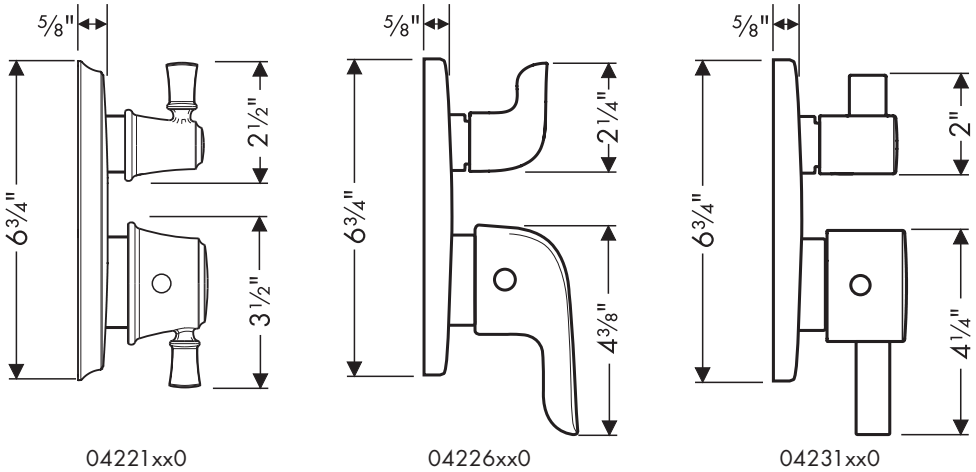

Technical Information / Données techniques / Datos técnicos

Recommended water pressure	Pression d'eau recommandée	Presión recomendada en servicio	15 - 75 PSI
Max. water pressure	Pression d'eau maximum	Presión en servicio max.	145 PSI
Recommended hot water temp.	Température recommandée d'eau chaude	Temperatura recomendada del agua caliente	120° - 140° F*
Max. hot water temp	Température maximum d'eau chaude	Temperatura del agua caliente max.	176° F*
Flow rate @ 44 PSI	Capacité nominale	Caudal máximo	8 GPM

*Please know and follow all applicable local plumbing codes when setting the temperature on the water heater.

* Vous devez connaître et respecter tous les codes de plomberie locaux applicables pour le réglage de la température du chauffe-eau.

*Debe conocer y cumplir todos los códigos locales aplicables para ajustar la temperatura del calentador de agua.

Installation Considerations

- For best results, Hansgrohe recommends that this unit be installed by a licensed, professional plumber.
- Please read over these instructions thoroughly before beginning installation. Make sure that you have all tools and supplies needed to complete the installation.
- This trim is for use with iBox Universal Plus model 01850181 (not included).
- To prevent scald injury, the maximum output temperature of the shower valve must be no higher than 120°F. In Massachusetts, the maximum output temperature can be no higher than 112° F.
- Keep this booklet and the receipt (or other proof of date and place of purchase) for this product in a safe place. The receipt is required should it be necessary to request warranty parts.

À prendre en considération pour l'installation

- Pour de meilleurs résultats, Hansgrohe recommande que ce produit soit installé par un plombier professionnel licencié.
- Ce dispositif requiert une pièce intérieure 01850181.
- Veuillez lire attentivement ces instructions avant de procéder à l'installation. Assurez-vous de disposer de tous les outils et du matériel nécessaires pour l'installation.
- Pour empêcher des blessures par ébullissement, la température de sortie maximale du robinet de douche ne doit pas excéder 120°F. Au Massachusetts, la température de sortie maximale du robinet de douche ne doit pas excéder 112°F.
- Conservez ce livret et le reçu (ou une autre preuve sur laquelle figurent la date et l'endroit de l'achat) pour ce produit dans un endroit sûr. Le reçu est requis si vous commandez des pièces sous garantie.

Consideraciones para la instalación

- Para obtener mejores resultados, Hansgrohe recomienda que la instalación de esta unidad esté a cargo de un plomero profesional matriculado.
- La unidad requiere una pieza interior de válvula 01850181.
- Antes de comenzar la instalación, lea estas instrucciones detenidamente. Asegúrese de tener las herramientas y los insumos necesarios para completar la instalación.
- Mantenga este folleto y el recibo (u otro comprobante del lugar y fecha de compra) de este producto en lugar seguro. El recibo se requiere en caso de ser necesario solicitar piezas bajo garantía.
- Para evitar escaldaduras, la máxima temperatura de salida de la válvula de la ducha no debe exceder los 120°F. En Massachusetts, la máxima temperatura de salida de la válvula de la ducha no debe exceder los 112°F.

Service Stops / Butées d'arrêt d'isolation / Cierres de servicio

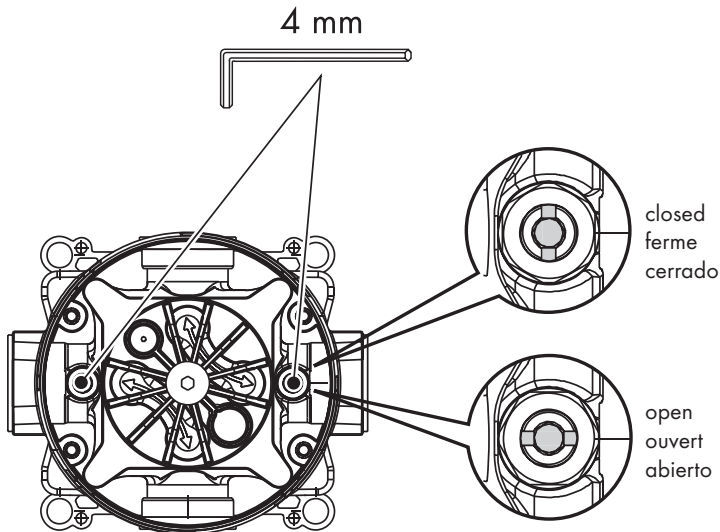

Installation

Flush the hot and cold supplies

- (1) Remove the dust cover.
- (2) Open the stops using a 4 mm Allen wrench.

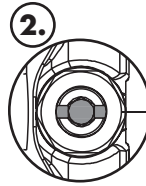
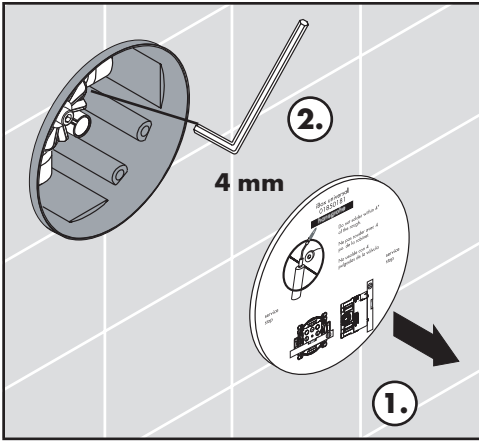

Allow the hot and cold supplies to flush for at least 5 minutes.

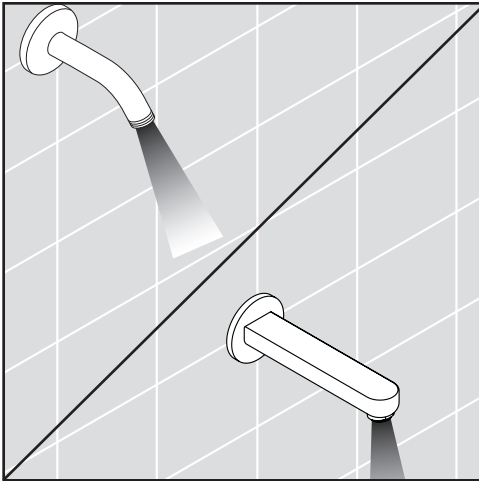

Close the stops using a 4 mm Allen wrench.

Cut the plaster shield so that it extends $\frac{1}{16}$ " - $\frac{1}{8}$ " from the finished wall surface.

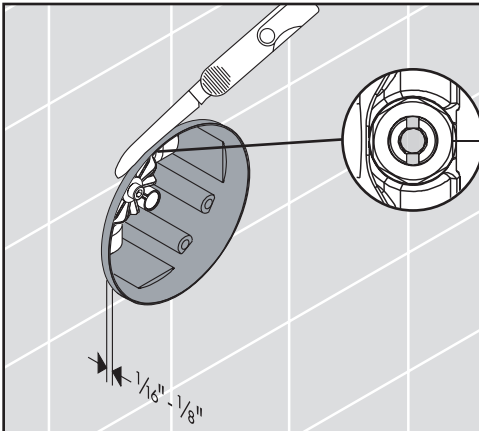

Installation

Rincez les conduites d'alimentation de l'eau chaude et de l'eau froide

- (1) Retirez l'étiquette.
- (2) Ouvrez l'eau à les butées d'arrêt d'isolation à l'aide d'une clé hexagonale de 4 mm.

Rincez les conduites de l'eau pour au moins 5 minutes.

 **Fermez l'eau à les butées d'arrêt d'isolation à l'aide d'une clé hexagonale de 4 mm.**

Coupez le protecteur de façon à ce qu'une partie de $\frac{1}{16}$ à $\frac{1}{8}$ po soit à l'extérieur de la surface du mur fini.

Instalación

Lave los suministros frío y caliente

- (1) Retire la etiqueta.
- (2) Abra los pasos del agua en los cierres de servicios con una llave Allen de 4 mm.

Lave los suministros de agua para por lo menos cinco minutos.

 **Cierre el paso del agua en la entrada del suministro o los cierres de servicio con una llave Allen de 4 mm.**

Corte el protector de yeso de modo que sobresalga $\frac{1}{16}$ " - $\frac{1}{8}$ " de la superficie de la pared terminada.

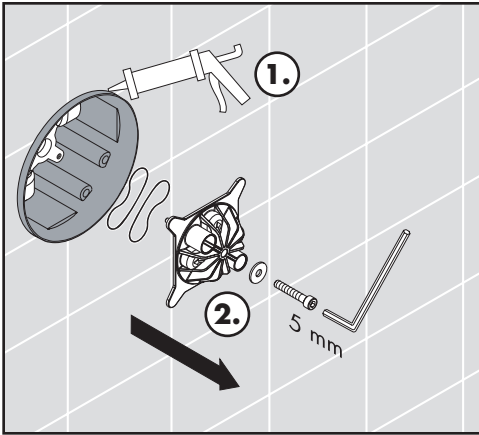

! Seal the wall around the plaster shield with waterproof sealant (1).

! Failure to seal the wall can lead to possible water damage.

Remove the flush insert screw, flush insert, and seals (2).

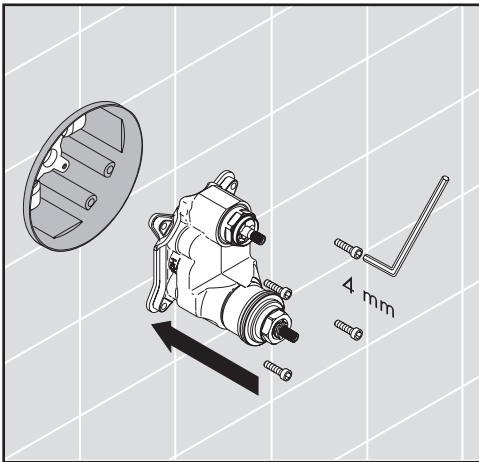

Insert the function block.

Install and tighten the function block screws using a 4 mm Allen wrench.

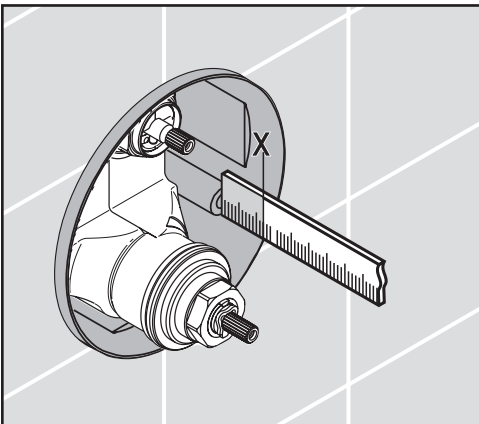

Measure the distance from the front of the plaster shield to one of the screw-in flanges ("X").

Français



Scellez le mur autour du protecteur à l'aide d'un agent d'étanchéité.



Si le mur n'est pas scellé, l'eau pourrait éventuellement causer des dommages.

Retirez la vis de la pièce d'insertion affleurante, la pièce d'insertion affleurante, et les joints (2).

Insérez le bloc de fonction.

Installez les vis du bloc de fonction à l'aide d'une clé hexagonale de 4 mm.

Mesurez la distance entre la surface du mur et la bride du vis. Notez la longueur mesurée (« X »).

Español



Selle la pared alrededor del protector de yeso con un sellador impermeable.



Si no se sella la pared, pueden producirse daños por acción del agua.

Quite los tornillos del inserto de lavado, el inserto de lavado, y las juntas (2).

Inserte el bloque de función.

Instale los tornillos del bloque de función con una llave Allen de 4 mm.

Mida la distancia entre la superficie de la pared y la brida de tornillo. Anote esta medida ("X").

English

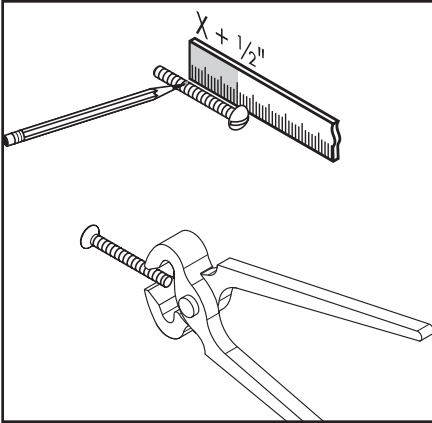

Add $\frac{1}{2}$ " to this measurement.

Cut each screw so that it is $X + \frac{1}{2}$ " long.

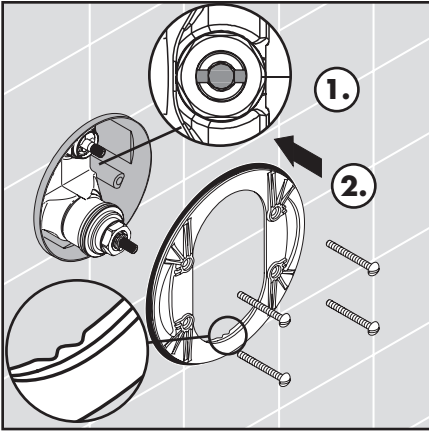

Open the stops (1).

Install the carrier plate so that the notch is at the bottom (2).

Install the carrier plate screws.

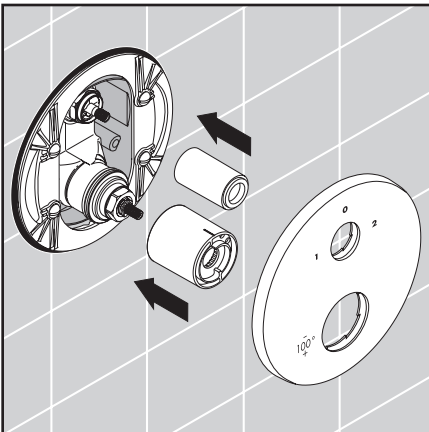

Push the thermostatic mixer sleeve on so that the indexing mark is at the 12:00 position.

Push the volume control sleeve on.

Install the escutcheon.

Français

Ajoutez $\frac{1}{2}$ po à cette longueur « X ». Notez cette longueur.

Coupez les vis de façon à ce que celui-ci dépasse de $\frac{1}{2}$ po + la longueur X.

Ouvrez les butées d'arrêt d'isolation (1).

Installez la plaque-support de façon à ce que l'encoche soit vers le bas (2).

Installez les vis de la plaque-support.

Installez la douille thermostatique de façon à ce que la marque de repère soit à la position 12:00.

Installez la douille inverseur / arrêt.

Installez le rosace.

Español

Agregue $\frac{1}{2}$ " a X. Anote esta medida.

Corte el tornillo de modo que sobresalga $\frac{1}{2}$ " + X.

Abra el paso del agua en los cierres de servicio (1).

Instale la placa del portador de manera que la ranura quede en la parte inferior (2).

Coloque los tornillos de la placa del portador.

Instale el casquillo de manera que la marca indicadora quede en posición de 12:00.

Instale el casquillo del llave de paso / distribuidor.

Instale el florón.

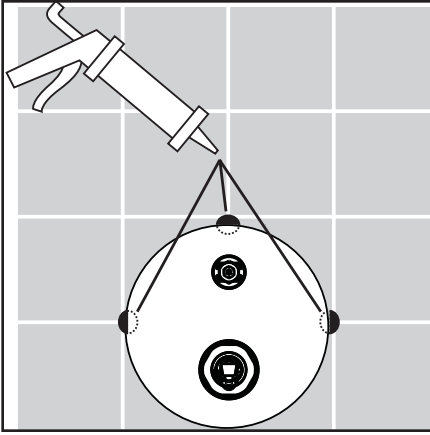

Place a dab of waterproof sealant at each grout joint.

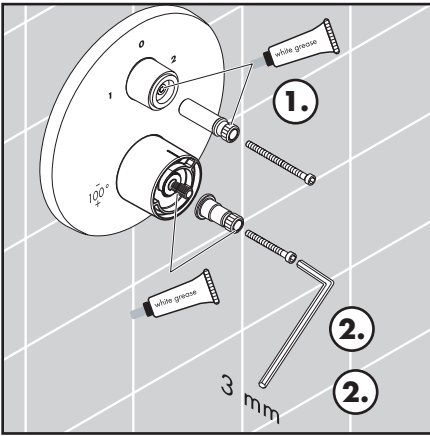

Lubricate the adapter stems with a small amount of white plumber's grease (1).

Install the handle adapters and screws (2). Tighten the screws using a 3 mm Allen wrench.

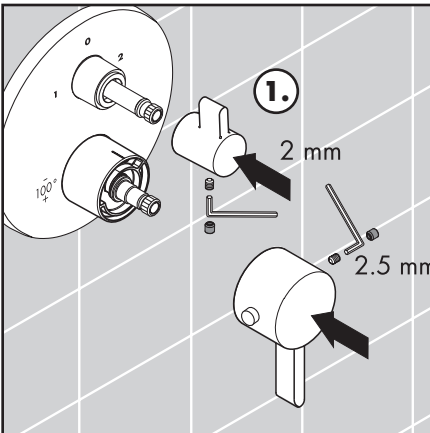

Install the volume control handle (1). Tighten the screw using a 2 mm Allen wrench.

Install the thermostatic mixer handle so that the safety stop override button is at the 9:00 position (2).

Tighten the handle screw using a 2.5 mm Allen wrench.

Français

Appliquer une petite quantité de l'agent d'étanchéité aux joints de coulis.

Lubrifiez la tige de manoeuvre avec une petite quantité de graisse de plomberie blanche (1).

Installez l'adaptateurs de poignées (2). Serrez les vis à l'aide d'une clé hexagonale de 3 mm.

Installez le poignée d'arrêt (1).

Installez la poignée thermostatique de façon à ce que le bouton de surpassement de la butée de sécurité soit à la position 9:00 (2).

Serrez la vis de la poignée à l'aide d'une clé hexagonale de 2.5 mm.

Español

Coloque un poco de sellador a prueba de agua en las uniones de la lechada de cemento.

Lubrique el vástago de la válvula con una pequeña cantidad de grasa blanca para plomería (1).

Instale el adaptador del mando (2). Apriete los tornillos con una llave Allen de 3 mm.

Instale el mando del llave de paso (1).

Instale el mando termostático de manera que el botón de vencimiento de tope de seguridad se encuentre en una posición de 90 grados (2).

Ajuste el tornillo del mando con una llave Allen de 2.5 mm.

Set the high temperature limit stop* *

Remove the clip and stop ring from the cartridge stem.

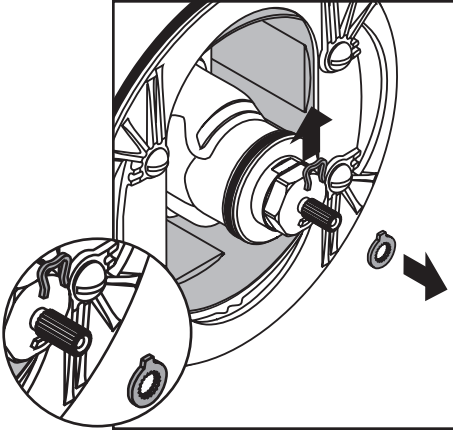

Turn the water on to one of the functions.

Turn the cartridge stem until the output water is the desired high temperature, usually 110° - 112° F**.

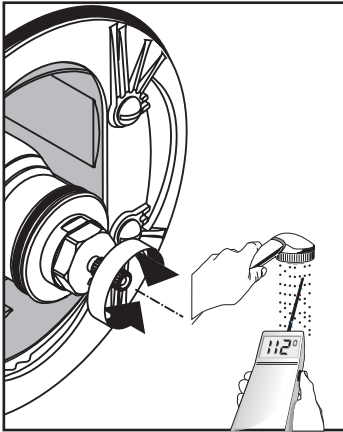

Replace the stop ring so that the tooth is against the cartridge stop. Replace the clip.

It should not be possible to turn the stem further counter-clockwise.

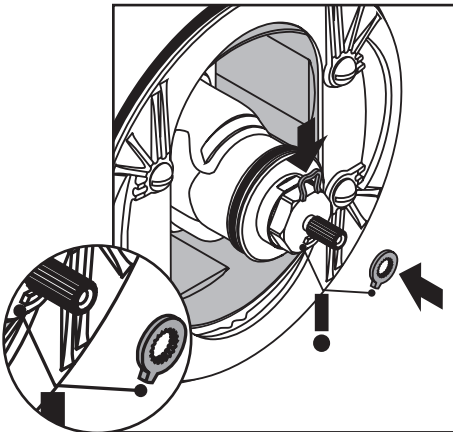

** Follow all applicable local plumbing codes when setting the high temperature limit stop.

Réglez la butée de limite d'eau chaude * *

Retirez l'étrier et la bague de retenue de la tige de la cartouche.

Faites couler l'eau en utilisant l'une des fonctions.

Tournez la tige de la cartouche jusqu'à ce que l'eau chaude soit à la température souhaitée, normalement entre 43 et 44 °C (110 et 112 °F)**.

Remettez la bague de retenue en place de façon à ce que la dent s'appuie sur la butée de la cartouche. Remettez l'étrier en place.

La tige ne doit pas pouvoir tourner plus loin dans le sens antihoraire.

Fije el tope de límite de alta temperatura * *

Retire la presilla y el aro de tope del vástago del cartucho.

Abra el paso del agua a una de las funciones.

Gire el vástago del cartucho hasta que el agua de salida tenga la temperatura alta deseada, normalmente entre 43 et 44 °C (110 et 112 °F)**.

Reemplace el aro de tope de manera que el diente esté contra el tope del cartucho. Reemplace la presilla.

No debería ser posible girar más el vástago en sentido antihorario.

Justify the handle

Loosen the handle screw. Remove the handle.

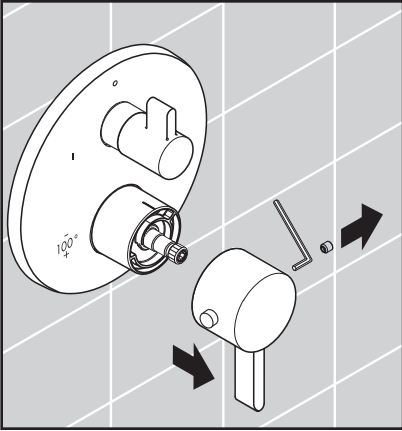

Turn the cartridge stem until the output water is 100° F.

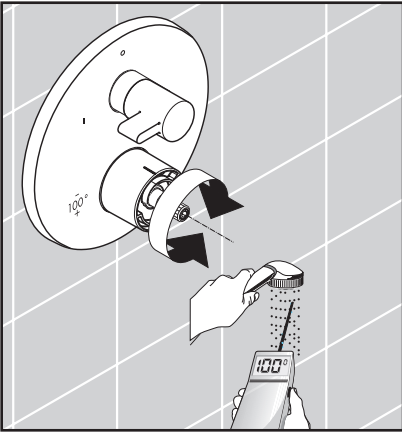

Install the handle so that the override button is next to the sleeve indexing mark.

Tighten the handle screw.

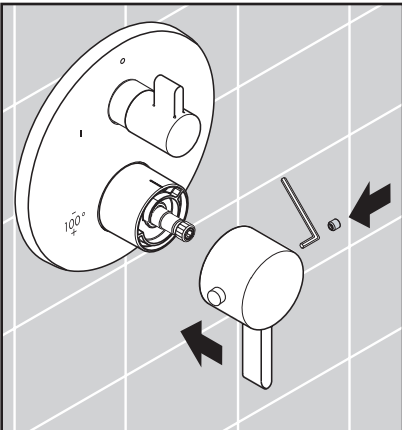

Réglez la poignée

Desserrez la vis de la poignée. Retirez la poignée.

Tournez la tige de la cartouche jusqu'à ce que l'eau soit à une température de 100 °F.

Installez la poignée de façon à ce que le bouton de surpassement soit près de la marque de repère du manchon.

Serrez la vis de la poignée.

Ajuste el mando

Afloje el tornillo del mando. Retire el mando.

Gire el vástago del cartucho hasta que el agua de salida esté en 100 °F.

Instale el mando de manera que el botón de vencimiento se encuentre al lado de la marca indicadora del casquillo.

Apriete el tornillo del mando.

Modify the diverter to allow simultaneous use of both functions

! Do not carry out this modification if:

- your local plumbing code does not allow the use of two shower functions simultaneously.
- the homeowner does not desire this ability.

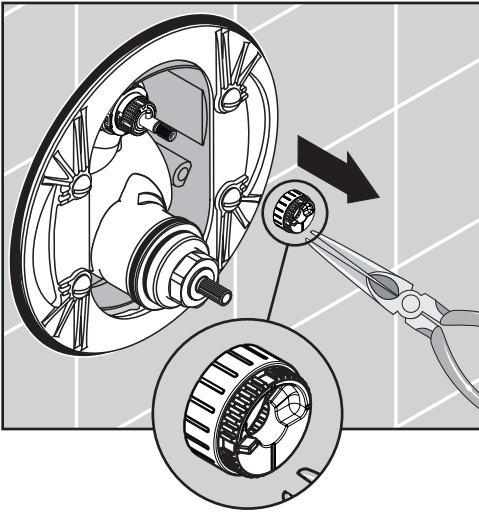

Remove the diverter cartridge stop ring.

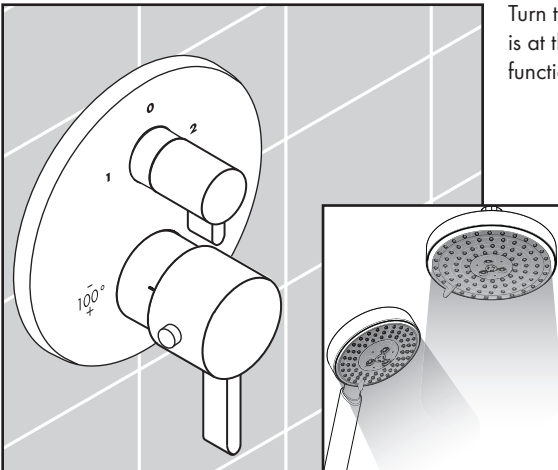

Turn the diverter handle so that the indexing mark is at the 6:00 position to obtain water from both functions simultaneously.

Modifiez l'inverseur pour permettre l'usage simultané des deux fonctions



Ne pas exécuter cette modification si :

- Votre code local de plomberie ne permet pas l'usage de deux fonctions de douche simultanément.
- Le propriétaire ne désire pas cette capacité.

Retirez l'anneau d'arrêt de cartouche de diverter.

Tourner la poignée de diverter pour que la marque d'indexation est à la 6:00 position d'obtenir de l'eau des deux fonctions simultanément.

Modifique el diverter para permitir el uso simultáneo de ambas funciones



No lleve a cabo esta modificación si:

- Su código local de la plomería no permite el uso de dos funciones de ducha simultáneamente.
- El propietario no desea esta capacidad.

Quite el anillo de la parada de cartucho de diverter.

Gire el asidero de diverter para que el indexando marca está en la 6:00 posición de obtener agua de ambas funciones simultáneamente.

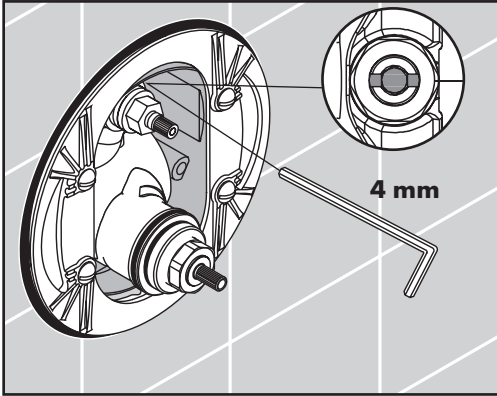

Clean the cartridge filters

Remove the trim.

Close both stops using a 4 mm Allen wrench.

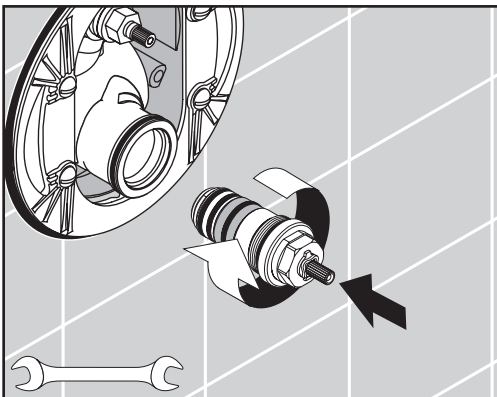
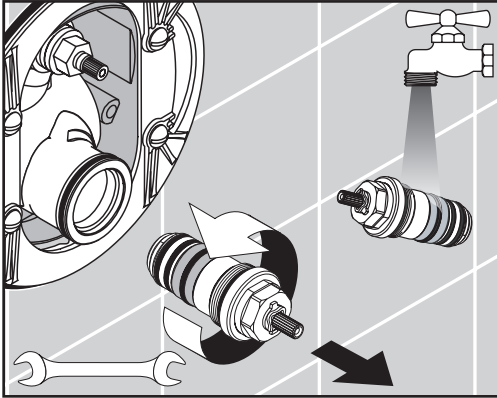

Nettoyez les filtres

Retirez le jeu de garniture.

Fermez l'eau à les butées d'arrêt d'isolation à l'aide d'une clé hexagonale de 4 mm.

Retirez la cartouche thermostatique à l'aide d'une clé.

Rincez les filtres avec l'eau claire.

Remplacez la cartouche thermostatique.

Ouvrez l'eau à les butées d'arrêt d'isolation.

Remplacez le jeu de garniture.

Limpiar los filtros

Retire el juego de la pieza exterior.

Cierre el paso del agua en la entrada del suministro o los cierres de servicio con una llave Allen de 4 mm.

Retire el cartucho termostático.

Lave los filtros.

Instale el cartucho termostático.

Abra el paso del agua en la entrada del suministro o los cierres de servicio con una llave Allen de 4 mm.

Instale el juego de la pieza exterior.

Troubleshooting

Problem	Possible Cause	Solution
Insufficient water	Supply pressure inadequate	Check water pressure
	Cartridge filters dirty	Clean the filters (see page 18)
	Showerhead or handshower filter dirty	Clean the filter
Crossflow: hot water forced into cold water supply or vice versa when mixture is closed	Check valves dirty or worn	Clean check valves, replace if necessary
Output temperature does not correspond with temperature marked on handle	Handle not justified	Justify the handle
	Water heater set too low	Increase the hot water temperature
Safety stop button not operating	Button and/or spring are dirty or worn	Clean spring and button, replace if necessary
Handle hard to turn	Cartridge dirty or worn	Replace cartridge
Shower or spout dripping	Volume control cartridge dirty or worn	Clean or replace volume control cartridge
Temperature regulation not possible	(new installation) Hot and cold supplies are reversed	Turn the function block 180°
	Thermostatic cartridge dirty or worn	Replace the thermostatic cartridge

Dépannage

Dysfonctionnement	Origine	Solution
Pas assez d'eau	Pression d'alimentation insuffisante Filtre de l'élément thermostatique encrassé Joint-filtre de douchette encrassé	Contrôlez la pression Nettoyez les filtres (voir p. 18) Nettoyez le joint-filtre entre la douchette et le flexible
Circulation opposée, l'eau chaude est comprimée dans l'arrivée d'eau froide et vice versa avec robinet fermé	Clapet anti-retour encrassé ou défectueux	Nettoyez le clapet anti-retour ou le changez éventuellement
La température à la sortie ne correspond pas à la température de réglage	Clapet anti-retour encrassé ou défectueux	Réglez le thermostat
Le réglage de la température n'est pas possible	L'élément thermostatique est encrassé ou entartré La pièce de base a une alimentation inversée (l'eau froide doit être à droite et l'eau chaude à gauche) ou elle est montée à l'envers	Nettoyez l'élément thermostatique ou le changez éventuellement Montez le bloc de fonction à 180°

Dysfonctionnement

Bouton à pression du verrouillage de sécurité défectueux

Fonctionnement de la poignée difficile

La douchette ou le bec verseur goutte

Origine

Ressort défectueux
Bouton à pression entartré

Mécanisme d'arrêt défectueux

De la saleté ou de l'incrustation sur le siège, mécanisme d'arrêt défectueux

Solution

Nettoyez le ressort ou bien le bouton à pression, le changez éventuellement

Changez le mécanisme d'arrêt

Nettoyez le mécanisme d'arrêt ou le changez éventuellement

Troubleshooting

Problema

Sale poca agua

Flujo de agua cruzada agua caliente entra en la tubería del agua fría o al revés

Temperatura del agua no corresponde a lo marcado

No es posible regular la temperatura

Botón de tope no funciona

Llave de paso va duro

Llave de paso pierde agua

Causa

presión insuficiente
filtro del termoelemento sucio
filtro de la ducha sucio

válvula antirretorno sucia o pierde

termostato no ha sido ajustado

termoelemento sucio/lleño de cal cuerpo empotrado mal montado (debe estar: frío = derecha) o instalado girado en 180°

muelle defecto
botón lleño de cal

montura dañada
suciedad/cal en el asiento de la junta o montura dañada

Solución

comprobar presión
limpiar filtro (ver página 18)
limpiar / cambiar filtros entre flexo y ducha

limpiar / cambiar válvula

ajustar termostato

limpiar / cambiar termoelemento
girar embellecedor en 180°

limpiar / cambiar

cambiar montura

limpiar / cambiar montura

Replacement Parts / Pièces détachées / Repuestos

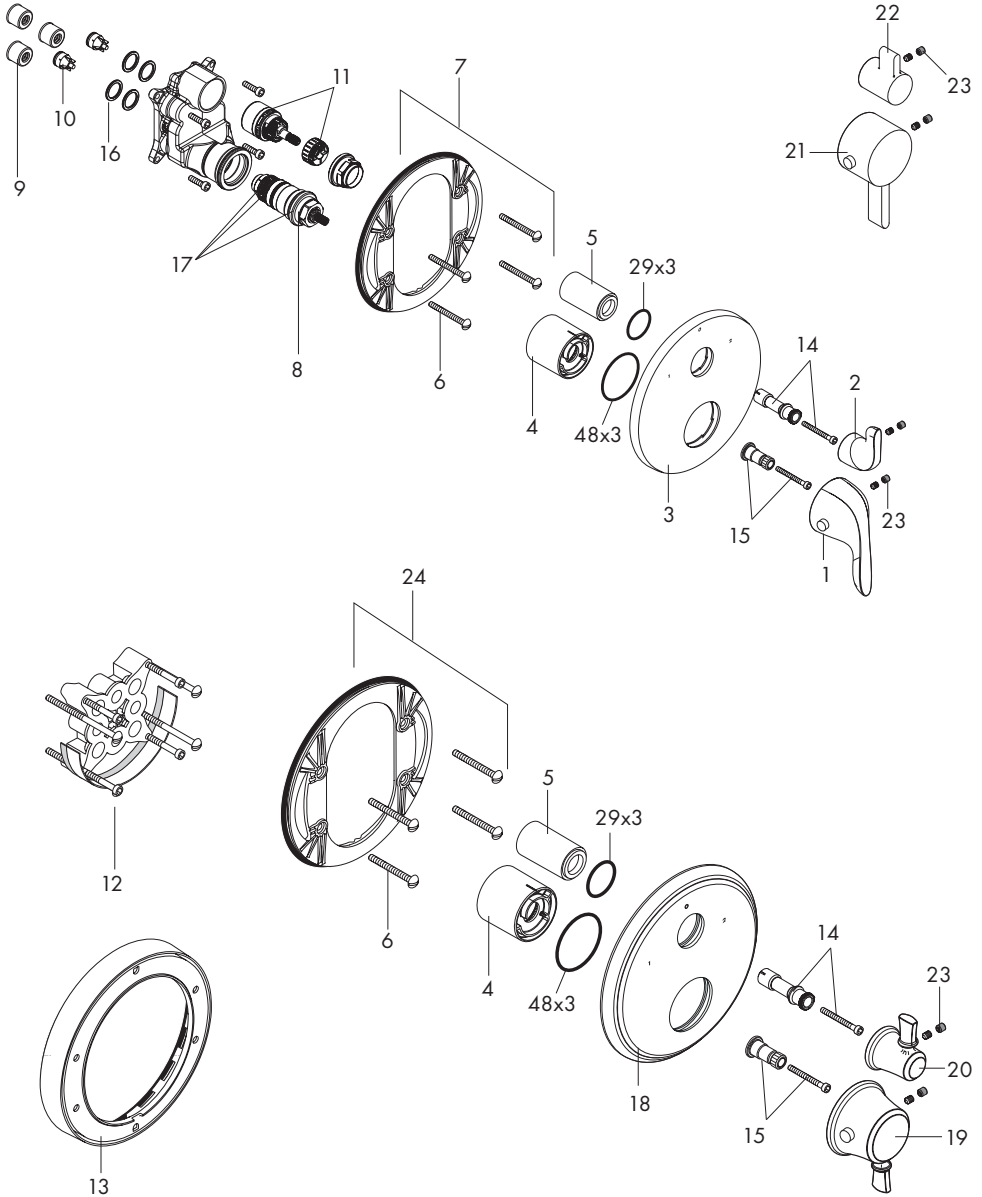

1	E thermostat handle	poignée thermostatique E	mando del termostato E	88771xx0
2	E volume control handle	poignée E	mando E	88768xx0
3	escutcheon	rosace	florón	96552xx1
4	sleeve	douille	casquillo	95550xx0
5	sleeve	douille	casquillo	95253xx0
6	fixing screw (set)	vis du support (set)	tornillo portador (set)	96454000
7	carrier plate	support de rosace	portador florón	96647000
8	thermostatic cartridge	cartouche thermostatique	termoelemento	94282000
9	noise reducer	silencieux	silenciador	94073000
10	check valve	clapet anti-retour	válvula antirretorno	94074000
11	volume control /diverter cartridge	mécánisme d'arrêt / inverseur	montura llave de paso / distribuidor	98283000
12	extension	rallonge 25 mm	alargo 25 mm	13595000
13	extension	rallonge 22 mm	alargo 22 mm	13596000
14	handle adapter	adaptateur pour poignée	adaptador mando	88772000
15	handle adapter	adaptateur pour poignée	adaptador mando	96435000
16	o-ring 16 x 2	joint torique 16 x 2	junta toroidal 16 x 2	98133000
17	sealing set	set de joint	junta	95037000
18	C escutcheon	rosace C	florón C	95556xx1
19	C thermostat handle	poignée thermostatique C	mando del termostato C	88773xx0
20	C volume control handle	poignée C	mando C	88770xx0
21	S thermostat handle	poignée thermostatique S	mando del termostato S	88772xx0
22	S volume control handle	poignée S	mando S	88769xx0
23	screw cover	cache vis	tapón	95181000
24	carrier plate	support de rosace	portador florón	98793000

xx = Finishes / Couleurs / Acabados

00 = chrome

62 = oil rub bronze

82 = brushed nickel

83 = polished nickel

92 = rubbed bronze

93 = polished brass

Cleaning Recommendation for Hansgrohe Products

Modern lavatory faucets, kitchen faucets, and showers consist of very different materials to comply with the needs of the market with regard to design and functionality. To avoid damage and returns, it is necessary to consider certain criteria when cleaning.

Cleaning Materials for Faucets and Showers

Acids are a necessary ingredient of cleaning materials for removing lime, however please pay attention to the following points when cleaning faucets and showers:

- Only use cleaning materials which are explicitly intended for this type of application.
- Never use cleaning materials which contain hydrochloric, formic, phosphoric, or acetic acid, as they cause considerable damage.
- Never mix one cleaning material with another.
- Never use cleaning materials or appliances with an abrasive effect, such as unsuitable cleaning powders, sponge pads, or micro fiber cloths.

Cleaning Instructions for Faucets and Showers

Please follow the cleaning material manufacturer's instructions. In addition, pay attention to the following points:

- Clean the faucets and showers as and when required
- Use the amount of cleaning product and the amount of time recommended by the manufacturer. Do not leave the cleaner on the fixture longer than necessary.
- Regular cleaning can prevent calcification.
- When using spray cleaners, spray first onto a soft cloth or sponge. Never spray directly onto the faucet as droplets can enter openings and gaps and cause damage.
- After cleaning, rinse thoroughly with clean water to remove any cleaner residue.

Important

Residues of liquid soaps, shampoos, and shower foams can also cause damage, so rinse with clean water after using.

Please note: if the surface is already damaged, the effect of cleaning materials will cause further damage.

Components with damaged surfaces must be replaced or injury could result.

Damage caused by improper treatment is not covered under the warranty.

Recommandations pour le nettoyage des produits Hansgrohe

Les robinetteries modernes de lavabo, de cuisine et de douche utilisent des matériaux très différents pour répondre aux besoins du marché en termes de conception et de fonctionnalité. **Certaines règles de base doivent être respectées lors du nettoyage de ces produits afin d'éviter de les endommager ou d'avoir à les retourner.**

Produits de nettoyage pour robinetteries et douches

Les acides sont une partie intégrante nécessaire de tous les produits de détartrage; il faut cependant prendre les précautions suivantes lors du nettoyage des robinets et des douches :

- N'utilisez que des produits/articles de nettoyage conçus spécifiquement pour les articles de robinetterie et de douche.
- N'utilisez jamais de produits/articles de nettoyage contenant de l'acide chlorhydrique, formique, phosphorique ou acétique car ils pourraient causer des dommages considérables.
- Ne mélangez jamais deux produits de nettoyage.
- N'utilisez jamais de produits/articles de nettoyage de nature abrasive tels que poudres de nettoyage, tampons-éponge ou chiffons microfibre non appropriés.

Instructions de nettoyage pour robinetteries et douches

Veillez suivre les instructions du fabricant de produits/articles de nettoyage. **De plus, tenez compte des conseils suivants :**

Nettoyez vos produits de robinetterie et de douche aussi souvent que nécessaire.

- Utilisez la quantité de produit nettoyant et respectez la durée recommandée par le fabricant. **Ne laissez pas le produit sur les**

artículos de robinetterie plus longtemps que nécessaire.

- Un nettoyage régulier peut prévenir la formation de dépôts calcaires.
- Si vous utilisez des nettoyeurs en vaporisateur, vaporisez d'abord sur une éponge ou un chiffon. **Ne vaporisez jamais directement sur un robinet** : des gouttelettes pourraient s'infiltrer dans les ouvertures et les interstices et endommager celui-ci.
- Après le nettoyage, rincez abondamment avec de l'eau propre pour éliminer tout résidu de produit nettoyant.

Important

Les résidus de savon liquide, de shampooing et de mousse pour la douche peuvent également endommager la robinetterie; rincez donc avec de l'eau propre après utilisation de ces produits.

Veillez noter : si la surface est déjà endommagée, les produits de nettoyage l'endommageront encore plus.

Les composants dont la surface est endommagée devraient être remplacés sous peine d'entraîner des blessures.

Les dommages dus à un mauvais traitement ne sont pas couverts par la garantie.

Recomendación de limpieza para los productos de Hansgrohe

Hoy en día, las griferías de baño y de cocina así como duchas modernas se componen de materiales muy distintos para satisfacer las exigencias del mercado respecto al diseño y la funcionalidad. Para evitar daños reclamaciones hay que tener en cuenta ciertos aspectos tanto en el uso como en su limpieza posterior.

Para elucidado de las griferías y las duchas en principio hay que seguir lo siguiente:

- Usar sólo detergentes previstos específicamente para este campo de aplicación.
- No aplicar detergentes que contengan hipoclorito sódico, ácido clorhídrico, fórmico o acético porque pueden causar daños importantes.
- Detergentes que contienen ácido fosfórico tampoco pueden ser aplicados ilimitadamente.
- Por regla general no se deben mezclar detergentes.
- Tampoco se deben utilizar utensilios abrasivos, como son polvos abrasivos, esponjas o paños de microfibra.
- Si tienen que seguir siempre las instrucciones de uso de los fabricantes de los detergentes.
- La limpieza tiene que ser realizada según la dosificación y el tiempo de actuación, en función del objeto y ajustada a las necesidades específicas del mismo.
- Gracias a una limpieza periódica se pueden evitar las incrustaciones de cal.
- No conviene rociar el detergente en ningún caso sobre la grifería sino sobre los textiles y ejecutar la limpieza así porque el líquido puede entrar en aperturas o hendiduras de la grifería y causar daños.
- Después de la limpieza hay que aclarar con suficiente agua para eliminar completamente el resto de detergente.
- La utilización de limpiadores a vapor no está permitida, las altas temperaturas pueden dañar los productos.

Indicaciones importantes

Los residuos de productos de aseo como jabón líquido, champús y gel de ducha pueden dañar también los materiales.

Por lo que también se deberá prestar atención a lo siguiente: aclarar con abundante agua después del uso.

Con materiales ya dañados la acción de detergentes incrementará el desgaste de estos.

Los componentes con superficies dañadas deberán cambiarse, en otro caso se corre el peligro de lesionarse.

Los daños que resulten de un uso inadecuado no están incluidos en nuestra garantía.

Limited Lifetime Consumer Warranty

This product has been manufactured and tested to the highest quality standards by Hansgrohe, Inc. ("Hansgrohe"). This warranty is limited to Hansgrohe products which are purchased by a consumer in the United States after March 1, 1996, and installed in either the United States or Canada.

WHO IS COVERED BY THE WARRANTY

This warranty extends to the original consumer purchaser only. This warranty is non-transferable.

WHAT IS COVERED BY THE WARRANTY

This warranty covers only your Hansgrohe manufactured product. Hansgrohe warrants this product against defects in material or workmanship as follows: Hansgrohe will repair at no charge for parts only or, at its option, replace any product or part of the product that proves defective because of improper workmanship and/or material, under normal installation, use, service and maintenance. If Hansgrohe is unable to provide a replacement and repair is not practical or cannot be timely made, Hansgrohe may elect to refund the purchase price in exchange for the return of the product.

LENGTH OF WARRANTY

Replacement or repaired parts of products will be covered for the term of this warranty as stated in the following two sentences. If you are a consumer who purchased the product for use primarily for personal, family, or household purposes, this warranty extends for as long as you own the product and the home in which the product is originally installed. If you purchased the product for use primarily for any other purpose, including, without limitation, a commercial purpose, this warranty extends only (i) for 1 year, with respect to Hansgrohe and Commercial products, and (ii) for 5 years, with respect to AXOR products.

THIS WARRANTY DOES NOT COVER, AND HANSGROHE WILL NOT PAY FOR:

- A. Conditions, malfunctions or damage not resulting from defects in material or workmanship.
- B. Conditions, malfunctions or damage resulting from (1) normal wear and tear, improper installation, improper maintenance, misuse, abuse, negligence, accident or alteration, or (2) the use of abrasive or caustic cleaning agents or "no-rinse" cleaning products, or the use of the product in any manner contrary to the product instructions. (3) Conditions in the home such as excessive water pressure or corrosion.
- C. Labor or other expenses for the disconnection, deinstallation, or return of the product for warranty service, or for installation or reinstallation of the product (including but not limited to proper packaging and shipping costs), or for installation or reinstallation of the product.
- D. Accessories, connected materials and products, or related products not manufactured by Hansgrohe.

TO OBTAIN WARRANTY PARTS OR INFORMATION

Contact your Hansgrohe retailer, or contact Technical Service at:

Hansgrohe Inc.
1492 Bluegrass Lakes Parkway
Alpharetta GA 30004
Toll-free (800) 334-0455.

In requesting warranty service, you will need to provide

1. The sales receipt or other evidence of the date and place of purchase.
2. A description of the problem.
3. Delivery of the product or the defective part, postage prepaid and carefully packed and insured, to Hansgrohe Inc. 1492 Bluegrass Lakes Parkway, Alpharetta, Georgia 30004, Attention: Technical Service, if required by Hansgrohe.

When warranty service is completed, any repaired or replacement product or part will be returned to you postage prepaid.

EXCLUSIONS AND LIMITATIONS

REPAIR OR REPLACEMENT (OR, IN LIMITED CIRCUMSTANCES, REFUND OF THE PURCHASE PRICE) AS PROVIDED UNDER THIS WARRANTY IS THE EXCLUSIVE REMEDY OF THE PURCHASER. HANSGROHE NEITHER ASSUMES NOR AUTHORIZES ANY PERSON TO CREATE FOR IT ANY OBLIGATION OR LIABILITY IN CONNECTION WITH THIS PRODUCT.

HANSGROHE SHALL NOT BE LIABLE TO PURCHASER OR ANY PERSON FOR ANY INCIDENTAL, SPECIAL, OR CONSEQUENTIAL DAMAGES, ARISING OUT OF BREACH OF THIS WARRANTY OR ANY IMPLIED WARRANTY (INCLUDING MERCHANTABILITY).

Some States do not allow the exclusion or limitation of incidental or consequential damages, so the above limitation or exclusion may not apply to you. This warranty gives you specific legal rights, and you may have other rights which vary from State to State. You may be required by law to give us a reasonable opportunity to correct or cure any failure to comply before you can bring any action in court against us under the Magnuson-Moss Warranty Act.

PRODUCT INSTRUCTIONS AND QUESTIONS

Upon purchase or prior to installation, please carefully inspect your Hansgrohe product for any damage or visible defect. Prior to installing, always carefully study the enclosed instructions on the proper installation and the care and maintenance of the product. If you have questions at any time about the use, installation, or performance of your Hansgrohe product, or this warranty, please call or write to us or call us toll-free at 800 334 0455.

hansgrohe

Hansgrohe, Inc. • 1490 Bluegrass Lakes Parkway • Alpharetta, GA 30004
Tel. 770-360-9880 • Fax 770-360-9887

www.hansgrohe-usa.com

Installation Instructions / Warranty

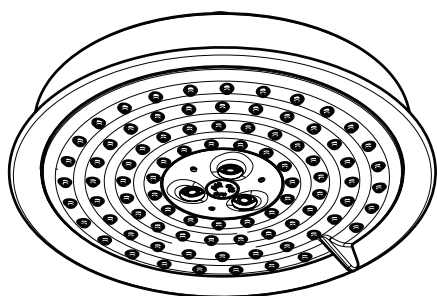

Raindance C 150
AIR 3jet
28471XX1

hansgrohe

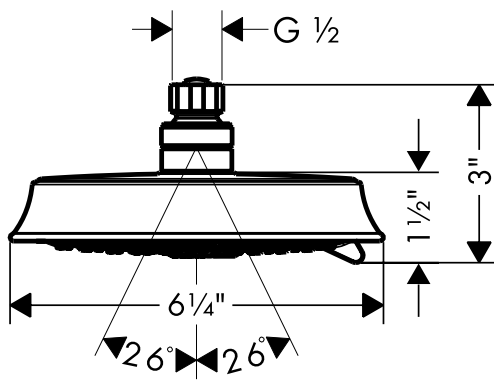

Technical Information

Flow rate

2.5 gpm

Installation Considerations

- For best results, Hansgrohe recommends that this unit be installed by a licensed, professional plumber.
- Please read over these instructions thoroughly before beginning installation. Make sure that you have all tools and supplies needed to complete the installation.
- To prevent scald injury, the maximum output temperature of the shower valve must be no higher than 120°F. In Massachusetts, the maximum output temperature of the shower valve can be no higher than 112°F.
- Keep this booklet and the receipt (or other proof of date and place of purchase) for this product in a safe place. The receipt is required should it be necessary to request warranty parts.

Installation

Install the showerhead on the arm.

Tighten using a 17 mm wrench.

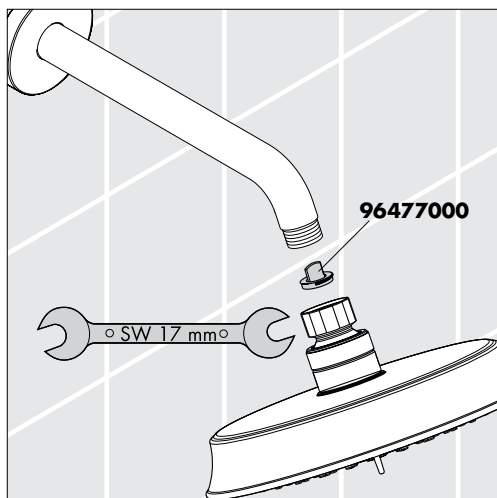

User Instructions

Push the function lever to the desired function.

Rain AIR



Balance AIR



Whirl AIR

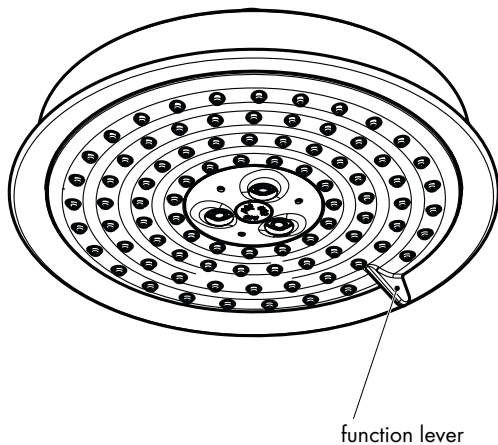

Remove scale deposits from the spray channels by rubbing across them with fingers or a sponge.

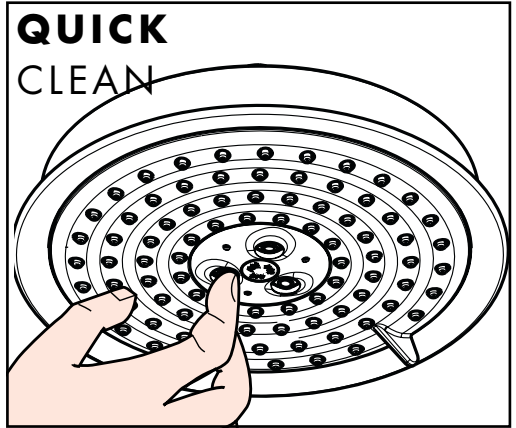

If the flow of water reduces over time, remove the filter gasket.

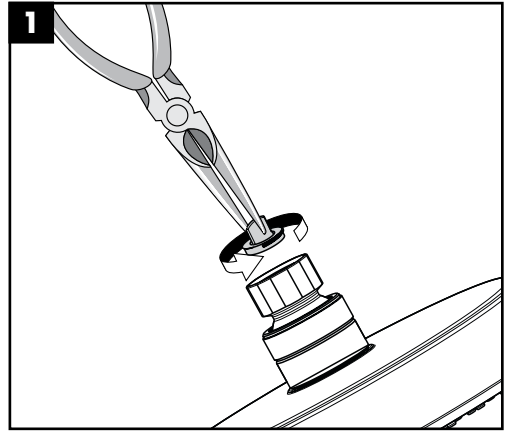

Rinse the filter gasket with clear water and replace.

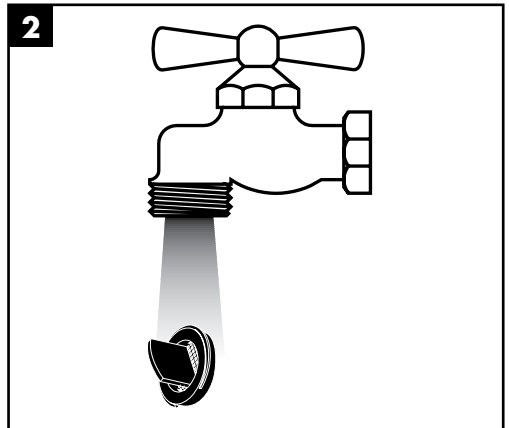

Remove scale deposits from the spray face by soaking it in a commercial scale remover such as Lime-Away or CLR.

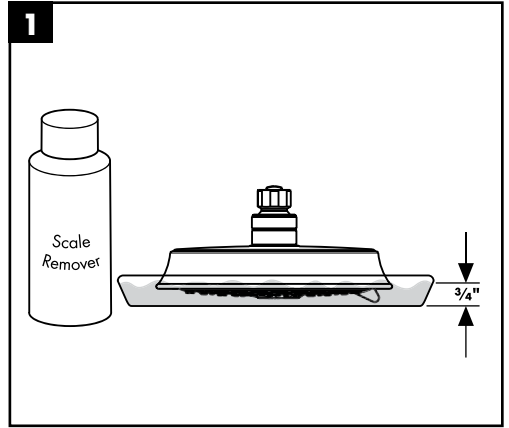

Follow the instructions on the product label.
Rinse the handshower with clear water.

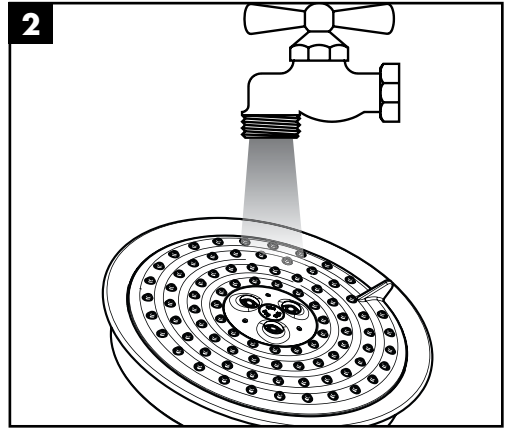

Install the handshower and flush it for at least one minute.

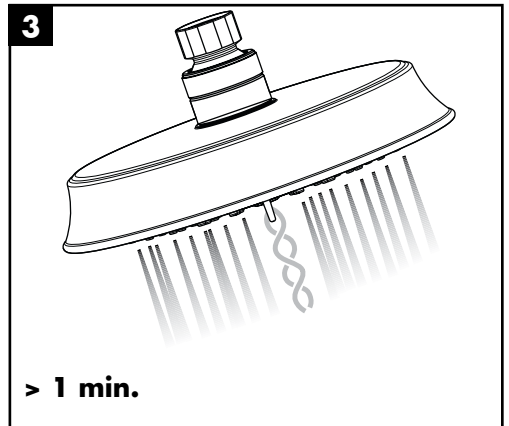

Cleaning Recommendation for Hansgrohe Products

Modern lavatory faucets, kitchen faucets, and showers consist of very different materials to comply with the needs of the market with regard to design and functionality. To avoid damage and returns, it is necessary to consider certain criteria when cleaning.

Cleaning Materials for Faucets and Showers

Acids are a necessary ingredient of cleaning materials for removing lime, however please pay attention to the following points when cleaning faucets and showers:

- Only use cleaning materials which are explicitly intended for this type of application.
- Never use cleaning materials which contain hydrochloric, formic, phosphoric, or acetic acid, as they cause considerable damage.
- Never mix one cleaning material with another.
- Never use cleaning materials or appliances with an abrasive effect, such as unsuitable cleaning powders, sponge pads, or micro fiber cloths.

Cleaning Instructions for Faucets and Showers

Please follow the cleaning material manufacturer's instructions. In addition, pay attention to the following points:

- Clean the faucets and showers as and when required
- Use the amount of cleaning product and the amount of time recommended by the manufacturer. Do not leave the cleaner on the fixture longer than necessary.
- Regular cleaning can prevent calcification.
- When using spray cleaners, spray first onto a soft cloth or sponge. Never spray directly onto the faucet as droplets can enter openings and gaps and cause damage.
- After cleaning, rinse thoroughly with clean water to remove any cleaner residue.

Important

Residues of liquid soaps, shampoos, and shower foams can also cause damage, so rinse with clean water after using.

Please note: if the surface is already damaged, the effect of cleaning materials will cause further damage.

Components with damaged surfaces must be replaced or injury could result.

Damage caused by improper treatment is not covered under the warranty.

Limited Lifetime Consumer Warranty

This product has been manufactured and tested to the highest quality standards by Hansgrohe, Inc. ("Hansgrohe"). This warranty is limited to Hansgrohe products which are purchased by a consumer in the United States after March 1, 1996, and installed in either the United States or Canada.

WHO IS COVERED BY THE WARRANTY

This warranty extends to the original consumer purchaser only. This warranty is non-transferable.

WHAT IS COVERED BY THE WARRANTY

This warranty covers only your Hansgrohe manufactured product. Hansgrohe warrants this product against defects in material or workmanship as follows: Hansgrohe will repair at no charge for parts only or, at its option, replace any product or part of the product that proves defective because of improper workmanship and/or material, under normal installation, use, service and maintenance. If Hansgrohe is unable to provide a replacement and repair is not practical or cannot be timely made, Hansgrohe may elect to refund the purchase price in exchange for the return of the product.

LENGTH OF WARRANTY

Replacement or repaired parts of products will be covered for the term of this warranty as stated in the following two sentences. If you are a consumer who purchased the product for use primarily for personal, family, or household purposes, this warranty extends for as long as you own the product and the home in which the product is originally installed. If you purchased the product for use primarily for any other purpose, including, without limitation, a commercial purpose, this warranty extends only (i) for 1 year, with respect to Hansgrohe and Commercial products, and (ii) for 5 years, with respect to AXOR products.

THIS WARRANTY DOES NOT COVER, AND HANSGROHE WILL NOT PAY FOR:

- A. Conditions, malfunctions or damage not resulting from defects in material or workmanship.
- B. Conditions, malfunctions or damage resulting from (1) normal wear and tear, improper installation, improper maintenance, misuse, abuse, negligence, accident or alteration, or (2) the use of abrasive or caustic cleaning agents or "no-rinse" cleaning products, or the use of the product in any manner contrary to the product instructions. (3) Conditions in the home such as excessive water pressure or corrosion.
- C. Labor or other expenses for the disconnection, deinstallation, or return of the product for warranty service, or for installation or reinstallation of the product (including but not limited to proper packaging and shipping costs), or for installation or reinstallation of the product.
- D. Accessories, connected materials and products, or related products not manufactured by Hansgrohe.

TO OBTAIN WARRANTY PARTS OR INFORMATION

Contact your Hansgrohe retailer, or contact Technical Service at:

Hansgrohe Inc.
1492 Bluegrass Lakes Parkway
Alpharetta GA 30004
Toll-free (800) 334-0455.

In requesting warranty service, you will need to provide

- 1. The sales receipt or other evidence of the date and place of purchase.
- 2. A description of the problem.
- 3. Delivery of the product or the defective part, postage prepaid and carefully packed and insured, to Hansgrohe Inc. 1492 Bluegrass Lakes Parkway, Alpharetta, Georgia 30004, Attention: Technical Service, if required by Hansgrohe.

When warranty service is completed, any repaired or replacement product or part will be returned to you postage prepaid.

EXCLUSIONS AND LIMITATIONS

REPAIR OR REPLACEMENT (OR, IN LIMITED CIRCUMSTANCES, REFUND OF THE PURCHASE PRICE) AS PROVIDED UNDER THIS WARRANTY IS THE EXCLUSIVE REMEDY OF THE PURCHASER. HANSGROHE NEITHER ASSUMES NOR AUTHORIZES ANY PERSON TO CREATE FOR IT ANY OBLIGATION OR LIABILITY IN CONNECTION WITH THIS PRODUCT.

HANSGROHE SHALL NOT BE LIABLE TO PURCHASER OR ANY PERSON FOR ANY INCIDENTAL, SPECIAL, OR CONSEQUENTIAL DAMAGES, ARISING OUT OF BREACH OF THIS WARRANTY OR ANY IMPLIED WARRANTY (INCLUDING MERCHANTABILITY).

Some States do not allow the exclusion or limitation of incidental or consequential damages, so the above limitation or exclusion may not apply to you. This warranty gives you specific legal rights, and you may have other rights which vary from State to State. You may be required by law to give us a reasonable opportunity to correct or cure any failure to comply before you can bring any action in court against us under the Magnuson-Moss Warranty Act.

PRODUCT INSTRUCTIONS AND QUESTIONS

Upon purchase or prior to installation, please carefully inspect your Hansgrohe product for any damage or visible defect. Prior to installing, always carefully study the enclosed instructions on the proper installation and the care and maintenance of the product. If you have questions at any time about the use, installation, or performance of your Hansgrohe product, or this warranty, please call or write to us or call us toll-free at 800 334 0455.

hansgrohe

Hansgrohe, Inc. • 1490 Bluegrass Lakes Parkway • Alpharetta, GA 30004
Tel. 770-360-9880 • Fax 770-360-9887

www.hansgrohe-usa.com

Installation Instructions / Warranty

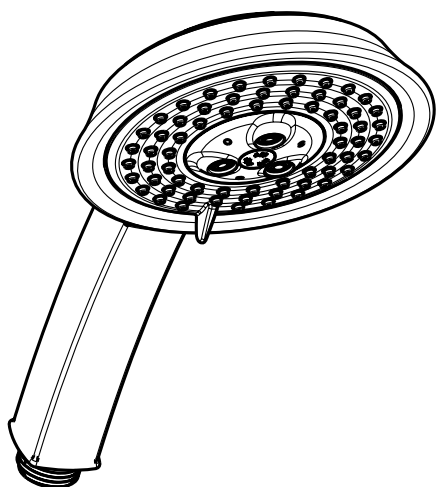

Raindance C 100
AIR 3jet
28548XX1

hansgrohe

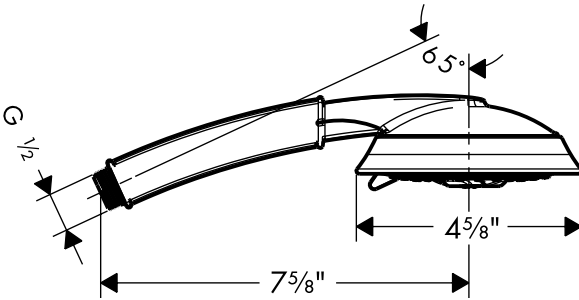
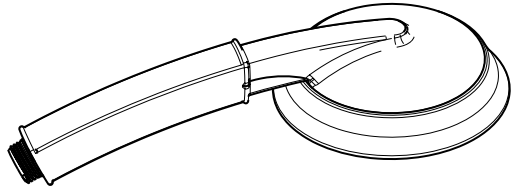
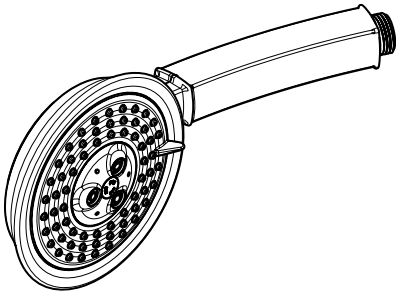

Rain AIR



Balance AIR



Whirl AIR



Technical Information

Flow rate

Données techniques

Capacité nominale

Datos tecnicos

Caudal máximo

2.5 gpm

Installation Considerations

- For best results, Hansgrohe recommends that this unit be installed by a licensed, professional plumber.
- Please read over these instructions thoroughly before beginning installation. Make sure that you have all tools and supplies needed to complete the installation.
- To prevent scald injury, the maximum output temperature of the shower valve should be no higher than 120°F. In Massachusetts, the maximum output temperature of the shower valve can be no higher than 112°F.
- Keep this booklet and the receipt (or other proof of date and place of purchase) for this product in a safe place. The receipt is required should it be necessary to request warranty parts.

À prendre en considération pour l'installation

- Pour de meilleurs résultats, Hansgrohe recommande que ce produit soit installé par un plombier professionnel licencié.
- Veuillez lire attentivement ces instructions avant de procéder à l'installation. **Assurez-vous** de disposer de tous les outils et du matériel nécessaires pour l'installation.
- Pour empêcher des blessures par ébullition, la température de sortie maximale du robinet de douche ne doit pas excéder 120°F. Au Massachusetts, la température de sortie maximale du robinet de douche ne doit pas excéder 112°F.
- Conservez ce livret et le reçu (ou une autre preuve sur laquelle figurent la date et l'endroit de l'achat) pour ce produit dans un endroit sûr. Le reçu est requis si vous commandez des pièces sous garantie.

Consideraciones para la instalación

- Para obtener mejores resultados, la instalación debe estar a cargo de un plomero profesional matriculado.
- Antes de comenzar la instalación, lea estas instrucciones detenidamente. Asegúrese de tener las herramientas y los insumos necesarios para completar la instalación.
- Para evitar escaldaduras, la máxima temperatura de salida de la válvula de la ducha no debe exceder los 120°F. En Massachusetts, la máxima temperatura de salida de la válvula de la ducha no debe exceder los 112°F.
- Mantenga este folleto y el recibo (u otro comprobante del lugar y fecha de compra) de este producto en lugar seguro. El recibo se requiere en caso de ser necesario solicitar piezas bajo garantía.

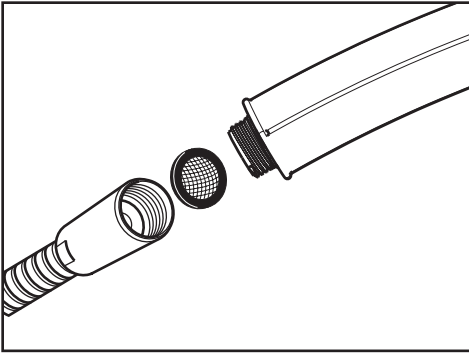

Installation

Place the screen washer in the end of the hose.
Connect this end of the hose to the handshower.

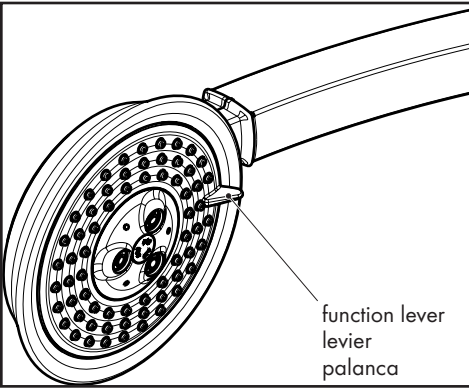

User Instructions

Push the function lever to the desired function.

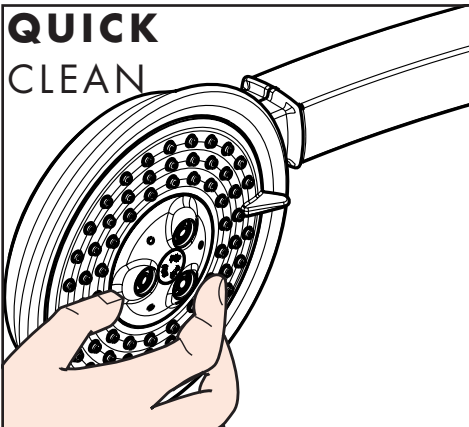

Remove scale deposits from the spray channels by rubbing across them with fingers or a sponge.

Installation

Placez le tamis dans l'extrémité du tuyau.

Connectez cette extrémité du tuyau à la douchette.

Instalación

Coloque la arandela de filtro en el extremo de la manguera.

Conecte este extremo de la manguera a la ducha de mano.

Instructions de service

Pour changer de mode de jet, pousser le levier.

Manejo

Cambie los modos de rociado pulsando la palanca.

Si les canaux de jet deviennent entartrés, frottez-les avec les doigts ou à l'aide d'une éponge pour en déloger les dépôts.

Elimine los depósitos calcificados de los canales de rociado frotándolos con los dedos o una esponja.

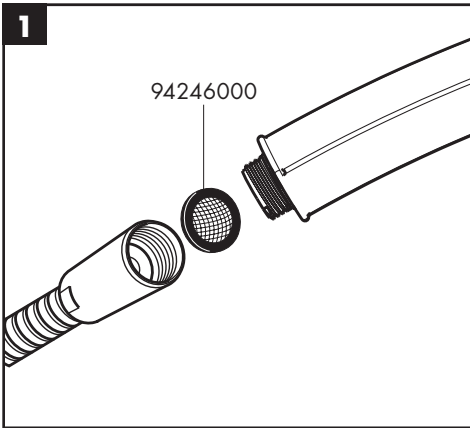

If the flow of water reduces over time, remove the screen washer.

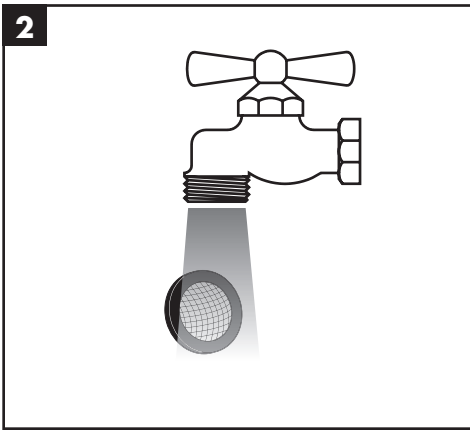

Rinse the screen washer with clear water and replace.

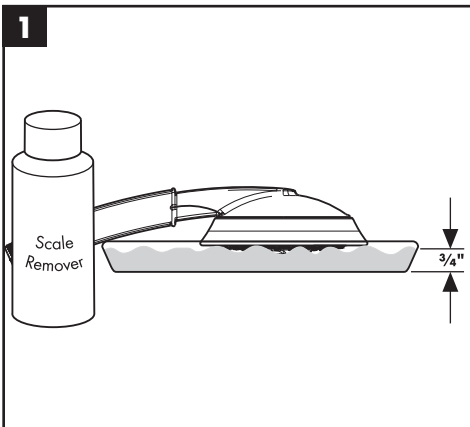

Remove scale deposits from the spray face by soaking it in a commercial scale remover such as Lime-Away or CLR.

Follow the instructions on the product label.

Français

Si le débit d'eau diminue avec le temps, retirez le tamis.

Rincez-le à l'eau claire et remettez-le en place.

Si la face des jets s'entartre, faites-la tremper dans un détartrant commercial, tel que Lime-Away ou CLR.

Suivez les instructions figurant sur l'étiquette du produit.

Español

Si el caudal de agua disminuye con el tiempo, retire la arandela de filtro de la manguera.

Enjuague la arandela de filtro con agua limpia y vuelva a colocarla.

Elimine los depósitos calcificados de la superficie de rociado remojándola en un desincrustante comercial como Lime-Away o CLR.

Siga las instrucciones de la etiqueta del producto.

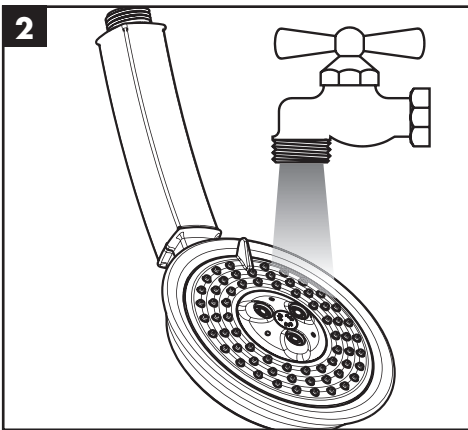

Rinse the handshower with clear water.

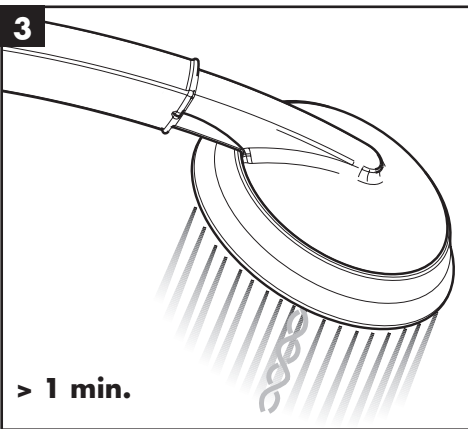

Install the handshower and flush it for at least one minute.

Rincez la douchette à l'eau claire.

Enjuague la ducha de mano con agua limpia.

Installez la douchette et faites-la fonctionner pendant au moins une minute.

Instale la ducha de mano y lávela durante un minuto como mínimo.

Cleaning Recommendation for Hansgrohe Products

Modern lavatory faucets, kitchen faucets, and showers consist of very different materials to comply with the needs of the market with regard to design and functionality. To avoid damage and returns, it is necessary to consider certain criteria when cleaning.

Cleaning Materials for Faucets and Showers

Acids are a necessary ingredient of cleaning materials for removing lime, however please pay attention to the following points when cleaning faucets and showers:

- Only use cleaning materials which are explicitly intended for this type of application.
- Never use cleaning materials which contain hydrochloric, formic, phosphoric, or acetic acid, as they cause considerable damage.
- Never mix one cleaning material with another.
- Never use cleaning materials or appliances with an abrasive effect, such as unsuitable cleaning powders, sponge pads, or micro fiber cloths.

Cleaning Instructions for Faucets and Showers

Please follow the cleaning material manufacturer's instructions. In addition, pay attention to the following points:

- Clean the faucets and showers as and when required
- Use the amount of cleaning product and the amount of time recommended by the manufacturer. Do not leave the cleaner on the fixture longer than necessary.
- Regular cleaning can prevent calcification.
- When using spray cleaners, spray first onto a soft cloth or sponge. Never spray directly onto the faucet as droplets can enter openings and gaps and cause damage.
- After cleaning, rinse thoroughly with clean water to remove any cleaner residue.

Important

Residues of liquid soaps, shampoos, and shower foams can also cause damage, so rinse with clean water after using.

Please note: if the surface is already damaged, the effect of cleaning materials will cause further damage.

Components with damaged surfaces must be replaced or injury could result.

Damage caused by improper treatment is not covered under the warranty.

Recommandations pour le nettoyage des produits Hansgrohe

Les robinetteries modernes de lavabo, de cuisine et de douche utilisent des matériaux très différents pour répondre aux besoins du marché en termes de conception et de fonctionnalité. **Certaines règles de base doivent être respectées lors du nettoyage de ces produits afin d'éviter de les endommager ou d'avoir à les retourner.**

Produits de nettoyage pour robinetteries et douches

Les acides sont une partie intégrante nécessaire de tous les produits de détartrage; il faut cependant prendre les précautions suivantes lors du nettoyage des robinets et des douches :

- N'utilisez que des produits/articles de nettoyage conçus spécifiquement pour les articles de robinetterie et de douche.
- N'utilisez jamais de produits/articles de nettoyage contenant de l'acide chlorhydrique, formique, phosphorique ou acétique car ils pourraient causer des dommages considérables.
- Ne mélangez jamais deux produits de nettoyage.
- N'utilisez jamais de produits/articles de nettoyage de nature abrasive tels que poudres de nettoyage, tampons-éponge ou chiffons microfibre non appropriés.

Instructions de nettoyage pour robinetteries et douches

Veillez suivre les instructions du fabricant de produits/articles de nettoyage. **De plus, tenez compte des conseils suivants :**

Nettoyez vos produits de robinetterie et de douche aussi souvent que nécessaire.

- Utilisez la quantité de produit nettoyant et respectez la durée recommandée par le fabricant. **Ne laissez pas le produit sur les articles de robinetterie plus longtemps que nécessaire.**
- Un nettoyage régulier peut prévenir la formation de dépôts calcaires.
- Si vous utilisez des nettoyeurs en vaporisateur, vaporisez d'abord sur une éponge ou un chiffon. **Ne vaporisez jamais directement sur un robinet :** des gouttelettes pourraient s'infiltrer dans les ouvertures et les interstices et endommager celui-ci.
- Après le nettoyage, rincez abondamment avec de l'eau propre pour éliminer tout résidu de produit nettoyant.

Important

Les résidus de savon liquide, de shampoing et de mousse pour la douche peuvent également endommager la robinetterie; rincez donc avec de l'eau propre après utilisation de ces produits.

Veillez noter : si la surface est déjà endommagée, les produits de nettoyage l'endommageront encore plus.

Les composants dont la surface est endommagée devraient être remplacés sous peine d'entraîner des blessures.

Les dommages dus à un mauvais traitement ne sont pas couverts par la garantie.

Recomendación de limpieza para los productos de Hansgrohe

Hoy en día, las griferías de baño y de cocina así como duchas modernas se componen de materiales muy distintos para satisfacer las exigencias del mercado respecto al diseño y la funcionalidad. Para evitar daños reclamaciones hay que tener en cuenta ciertos aspectos tanto en el uso como en su limpieza posterior.

Para elucido de las griferías y las duchas en principio hay que seguir lo siguiente:

- Usar sólo detergentes previstos específicamente para este campo de aplicación.
- No aplicar detergentes que contengan hipoclorito sódico, ácido clorhídrico, fórmico o acético porque pueden causar daños importantes.
- Detergentes que contienen ácido fosfórico tampoco pueden ser aplicados ilimitadamente.
- Por regla general no se deben mezclar detergentes.
- Tampoco se deben utilizar utensilios abrasivos, como son polvos abrasivos, esponjas o paños de microfibra.
- Si tienen que seguir siempre las instrucciones de uso de los fabricantes de los detergentes.
- La limpieza tiene que ser realizada según la dosificación y el tiempo de actuación, en función del objeto y ajustada a las necesidades específicas del mismo.
- Gracias a una limpieza periódica se pueden evitar las incrustaciones de cal.
- No conviene rociar el detergente en ningún caso sobre la grifería sino sobre los textiles y ejecutar la limpieza así porque el líquido puede entrar en aperturas o hendiduras de la grifería y causar daños.
- Después de la limpieza hay que aclarar con suficiente agua para eliminar completamente el resto de detergente.
- La utilización de limpiadores a vapor no está permitida, las altas temperaturas pueden dañar los productos.

Indicaciones importantes

Los residuos de productos de aseo como jabón líquido, champús y gel de ducha pueden dañar también los materiales.

Por lo que también se deberá prestar atención a lo siguiente: aclarar con abundante agua después del uso.

Con materiales ya dañados la acción de detergentes incrementará el desgaste de estos.

Los componentes con superficies dañadas deberán cambiarse, en otro caso se corre el peligro de lesionarse.

Los daños que resulten de un uso inadecuado no están incluidos en nuestra garantía.

Limited Lifetime Consumer Warranty

This product has been manufactured and tested to the highest quality standards by Hansgrohe, Inc. ("Hansgrohe"). This warranty is limited to Hansgrohe products which are purchased by a consumer in the United States after March 1, 1996, and installed in either the United States or Canada.

WHO IS COVERED BY THE WARRANTY

This warranty extends to the original consumer purchaser only. This warranty is non-transferable.

WHAT IS COVERED BY THE WARRANTY

This warranty covers only your Hansgrohe manufactured product. Hansgrohe warrants this product against defects in material or workmanship as follows: Hansgrohe will repair at no charge for parts only or, at its option, replace any product or part of the product that proves defective because of improper workmanship and/or material, under normal installation, use, service and maintenance. If Hansgrohe is unable to provide a replacement and repair is not practical or cannot be timely made, Hansgrohe may elect to refund the purchase price in exchange for the return of the product.

LENGTH OF WARRANTY

Replacement or repaired parts of products will be covered for the term of this warranty as stated in the following two sentences. If you are a consumer who purchased the product for use primarily for personal, family, or household purposes, this warranty extends for as long as you own the product and the home in which the product is originally installed. If you purchased the product for use primarily for any other purpose, including, without limitation, a commercial purpose, this warranty extends only (i) for 1 year, with respect to Hansgrohe and Commercial products, and (ii) for 5 years, with respect to AXOR products.

THIS WARRANTY DOES NOT COVER, AND HANSGRÖHE WILL NOT PAY FOR:

- A. Conditions, malfunctions or damage not resulting from defects in material or workmanship.
- B. Conditions, malfunctions or damage resulting from (1) normal wear and tear, improper installation, improper maintenance, misuse, abuse, negligence, accident or alteration, or (2) the use of abrasive or caustic cleaning agents or "no-rinse" cleaning products, or the use of the product in any manner contrary to the product instructions. (3) Conditions in the home such as excessive water pressure or corrosion.
- C. Labor or other expenses for the disconnection, deinstallation, or return of the product for warranty service, or for installation or reinstallation of the product (including but not limited to proper packaging and shipping costs), or for installation or reinstallation of the product.
- D. Accessories, connected materials and products, or related products not manufactured by Hansgrohe.

TO OBTAIN WARRANTY PARTS OR INFORMATION

Contact your Hansgrohe retailer, or contact Technical Service at:

Hansgrohe Inc.
1492 Bluegrass Lakes Parkway
Alpharetta GA 30004
Toll-free (800) 334-0455.

In requesting warranty service, you will need to provide

1. The sales receipt or other evidence of the date and place of purchase.
2. A description of the problem.
3. Delivery of the product or the defective part, postage prepaid and carefully packed and insured, to Hansgrohe Inc. 1492 Bluegrass Lakes Parkway, Alpharetta, Georgia 30004, Attention: Technical Service, if required by Hansgrohe.

When warranty service is completed, any repaired or replacement product or part will be returned to you postage prepaid.

EXCLUSIONS AND LIMITATIONS

REPAIR OR REPLACEMENT (OR, IN LIMITED CIRCUMSTANCES, REFUND OF THE PURCHASE PRICE) AS PROVIDED UNDER THIS WARRANTY IS THE EXCLUSIVE REMEDY OF THE PURCHASER. HANSGRÖHE NEITHER ASSUMES NOR AUTHORIZES ANY PERSON TO CREATE FOR IT ANY OBLIGATION OR LIABILITY IN CONNECTION WITH THIS PRODUCT.

HANSGRÖHE SHALL NOT BE LIABLE TO PURCHASER OR ANY PERSON FOR ANY INCIDENTAL, SPECIAL, OR CONSEQUENTIAL DAMAGES, ARISING OUT OF BREACH OF THIS WARRANTY OR ANY IMPLIED WARRANTY (INCLUDING MERCHANTABILITY).

Some States do not allow the exclusion or limitation of incidental or consequential damages, so the above limitation or exclusion may not apply to you. This warranty gives you specific legal rights, and you may have other rights which vary from State to State. You may be required by law to give us a reasonable opportunity to correct or cure any failure to comply before you can bring any action in court against us under the Magnuson-Moss Warranty Act.

PRODUCT INSTRUCTIONS AND QUESTIONS

Upon purchase or prior to installation, please carefully inspect your Hansgrohe product for any damage or visible defect. Prior to installing, always carefully study the enclosed instructions on the proper installation and the care and maintenance of the product. If you have questions at any time about the use, installation, or performance of your Hansgrohe product, or this warranty, please call or write to us or call us toll-free at 800 334 0455.

hansgrohe

Hansgrohe, Inc. • 1490 Bluegrass Lakes Parkway • Alpharetta, GA 30004
Tel. 770-360-9880 • Fax 770-360-9887

www.hansgrohe-usa.com