

**INSTALLATION INSTRUCTIONS FOR MULLION SHIMS  
(ILLUSTRATION 5)**

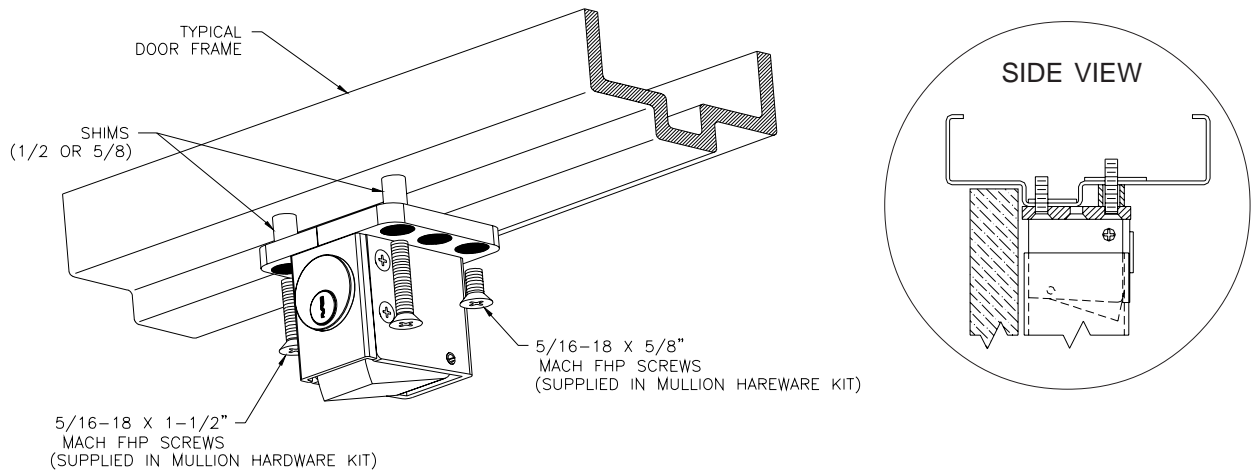

**NOTE:** The shims are to be used when the top fitting overhangs the stop.

- 1) Check stop height and match to shims supplied (1/2" or 5/8").
- 2) Install shims using the long screws (5/16-18 x 1-1/2" FHP) supplied in the hardware kit. (See Illustration 5 above)

## INSTRUCTIONS FOR THE FIRE RATED (F90KR) KEYED REMOVABLE MULLION

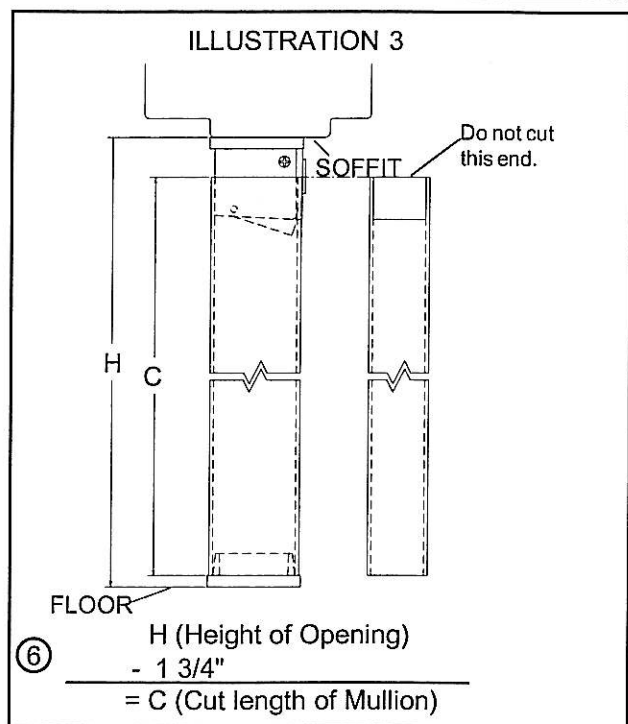
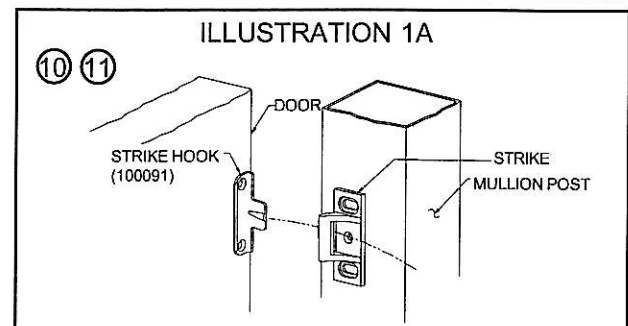
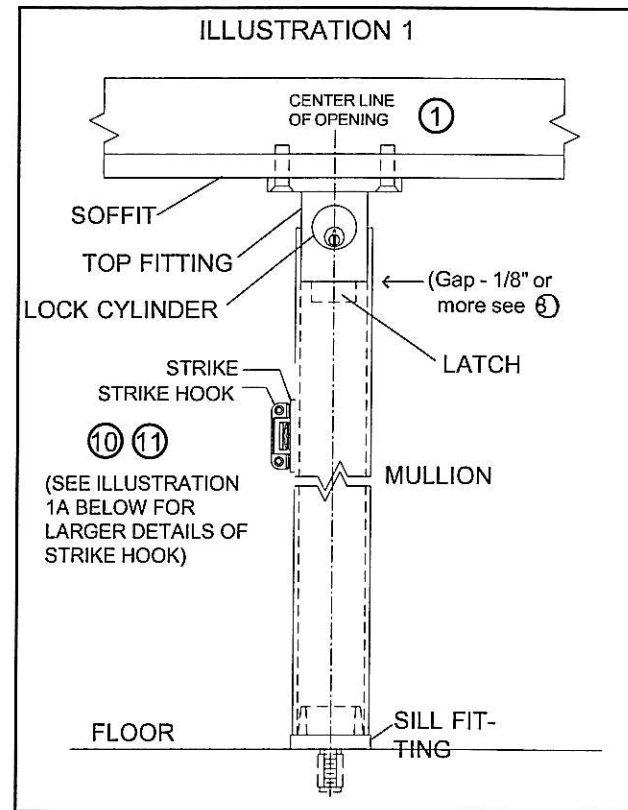

① Determine and mark the center of the width of the door opening at the soffit and at the floor (See illustration #1).

② Place the top fitting at the soffit of the frame and align the centering notch with the mark that you made in Step 1. Close the doors and butt the notched side to the doors. Mark and drill the soffit at the four (4) hole locations with # (F) bit (See illustration #2 or #2A). Tap the four (4) holes with 5/16"-18 tap. If top fitting over hangs the stop refer to the Installation Instructions for Mullion Shims (see Page 2 Illustration 5).

③ Cut rim cylinder tailpiece. See Illustration 4. Install the rim cylinder into the cylinder housing right side up. Be sure to use the rim cylinder backplate that comes with the kit and discard the backplate that is supplied with the rim cylinder. Remove the key from the cylinder before installing cylinder in the top fitting.

④ (See illustration #4). Raise deadlock with one finger. Slide cylinder housing into top fitting. Confirm that there is no movement of the latch. If the latch moves, the tailpiece is too long and must be cut shorter. Ensure rim cylinder tailpiece engages the cam in the top fitting while the fusible platform slides under the deadlock. Attach the cylinder housing with four (4) screws. Insert key and rotate 1/2 turn. The latch should retract fully. Turn the key back and remove the key. The latch should now extend fully. Ensure there is no binding on the latch/key.

⑤ Attach the top fitting to the soffit with the machine screws provided ( see illustration #2).

⑥ Trial fit the mullion. If it is too long, measure the distance from the soffit to the floor. Subtract 1-3/4" from this measurement, mark the mullion tube and cut from the bottom end with no cutout. (See illustration #3).

⑦ **If there is a threshold, be sure to cut the threshold so that the sill fitting is resting on the non-flammable flooring.** Place the mullion tube into the sill fitting and pivot the top upward into place. Close the doors again. Slide the sill fitting at the floor and butt the mullion to the doors. Align the centering notches on the fitting with the mark that you made in Step 1. Carefully remove the mullion. Mark and drill the floor at the two (2) hole locations (See illustration #2). See anchor for drill size.

⑧ Attach the sill fitting with the anchors and bolts provided (See illustration #2). Replace the mullion into the sill fitting and pivot the top upward into place. The mullion should snap firmly into place. If there is too much gap (1/8" or more between the cut out mullion tubing and the cylinder housing), install the shims provided to raise the sill fitting.

⑨ Ensure that the mullion is easily removable when the key is turned in its cylinder.

⑩ Attach the strikes to the side of the mullion according to the template provided with the locking device to be used.

⑪ Attach one strike hook per door leaf according to the template provided with the locking device to be used. Ensure that the strike hook engages the strike without interference to the latching mechanism. Open and close the door. The strike hook should not cause friction or bind during the opening and closing cycles of the door.

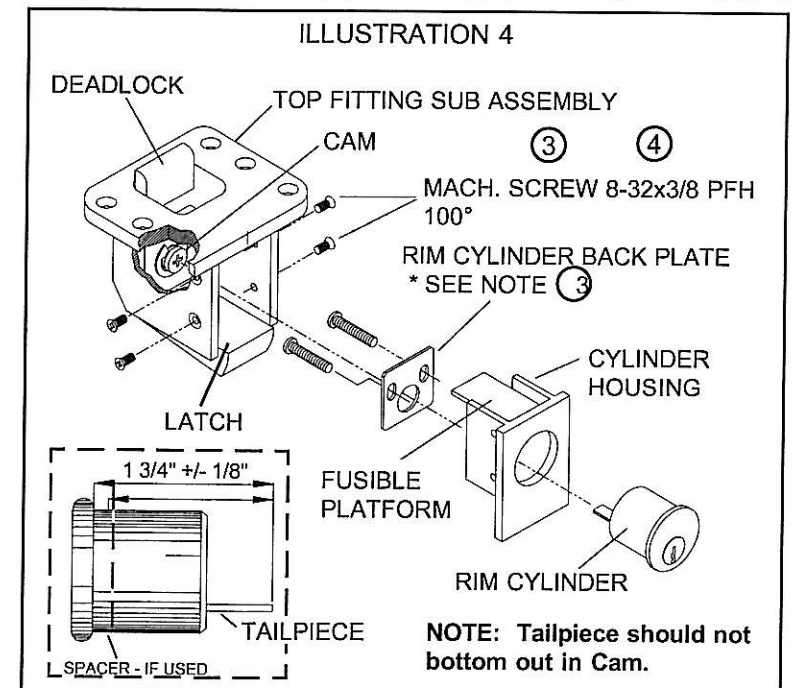
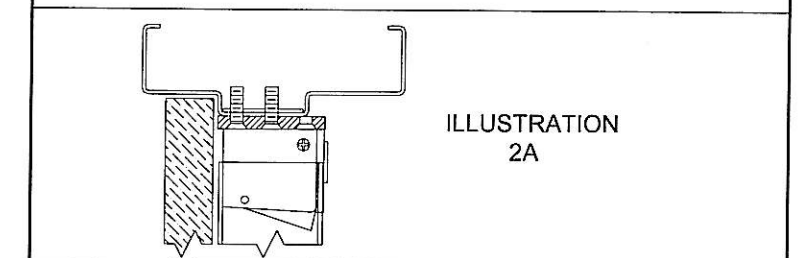
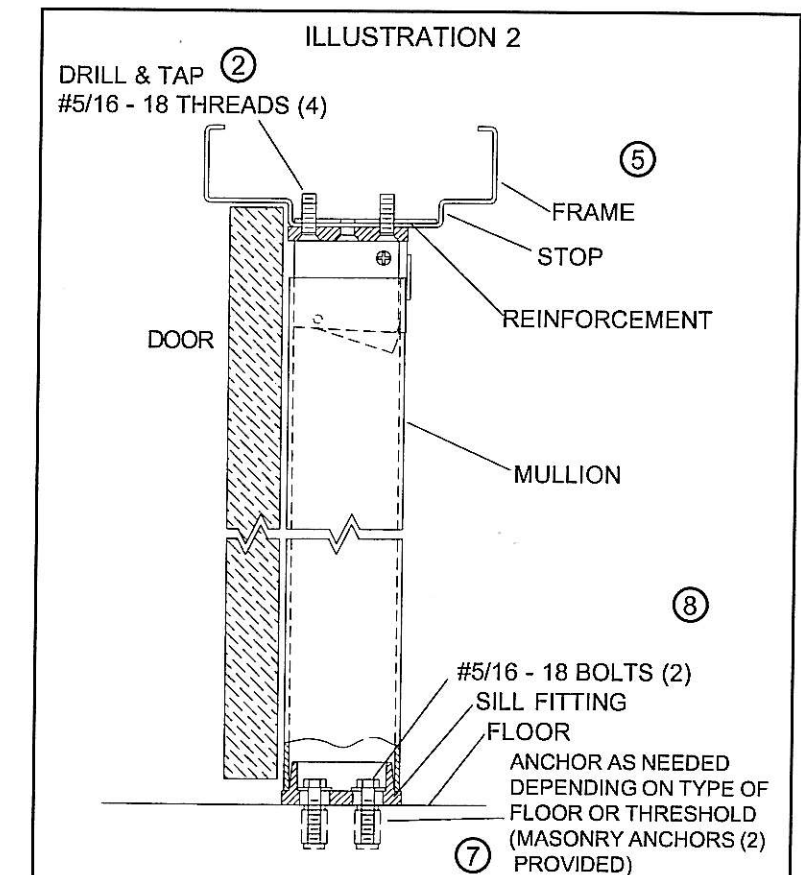

## INSTRUCTIONS FOR THE NON-FIRE RATED (90KR) KEYED REMOVABLE MULLION

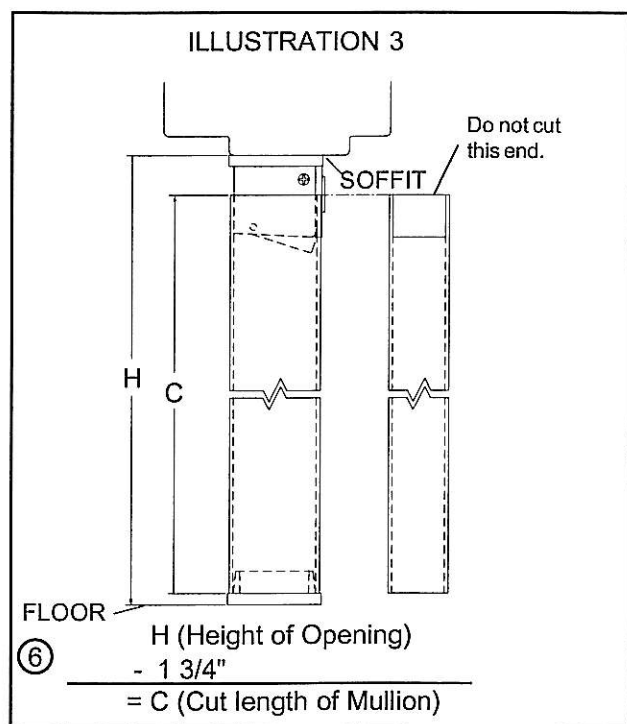
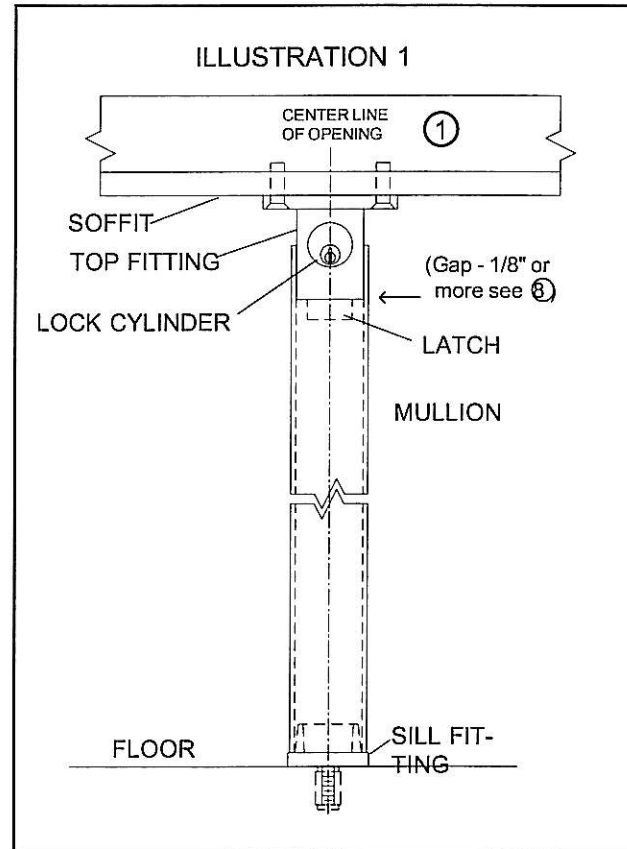

- ① Determine and mark the center of the width of the door opening at the soffit and at the floor (See illustration #1).
- ② Place the top fitting at the soffit of the frame and align the centering notch with the mark that you made in Step 1. Close the doors and butt the notched side to the doors. Mark and drill the soffit at the four (4) hole locations with # (F) bit (See illustration #2 or #2A). Tap the four (4) holes with 5/16"-18 tap. If top fitting over hangs the stop refer to the Installation Instructions for Mullion Shims (see Page 2 Illustration 5).
- ③ Cut rim cylinder tailpiece. See Illustration 4. Install the rim cylinder into the cylinder housing right side up. Be sure to use the rim cylinder backplate that comes with the kit and discard the backplate that is supplied with the rim cylinder. Remove the key from the cylinder before installing cylinder in the top fitting.
- ④ (See illustration # 4). Slide cylinder housing into top fitting. Confirm that there is no movement of the latch. If the latch moves, the tailpiece is too long and must be cut shorter. Ensure rim cylinder tailpiece engages the cam in the top fitting. Attach the cylinder housing with four (4) screws. Insert key and rotate 1/2 turn. The latch should retract fully. Turn the key back and remove the key. The latch should now extend fully. Ensure there is no binding on the latch/key.
- ⑤ Attach the top fitting to the soffit with the machine screws provided ( see illustration #2).
- ⑥ Trial fit the mullion. If it is too long, measure the distance from the soffit to the floor. Subtract 1-3/4" from this measurement, mark the mullion tube and cut from the bottom end with no cutout. (See illustration #3).
- ⑦ **If there is a threshold, be sure to cut the threshold so that the sill fitting is resting on the flooring.** Place the mullion tube into the sill fitting and pivot the top upward into place. Close the doors again. Slide the sill fitting at the floor and butt the mullion to the doors. Align the centering notches on the fitting with the mark that you made in Step 1. Carefully remove the mullion. Mark and drill the floor at the two (2) hole locations (See illustration #2). See anchor for drill size.
- ⑧ Attach the sill fitting with the anchors and bolts provided (See illustration #2). Replace the mullion into the sill fitting and pivot the top upward into place. The mullion should snap firmly into place. If there is too much gap (1/8" or more between the cut out mullion tubing and the cylinder housing), install the shims provided to raise the sill fitting.
- ⑨ Ensure that the mullion is easily removable when the key is turned in its cylinder.
- ⑩ Attach the strikes to the side of the mullion according to the template provided with the locking device to be used.

